



*Personal Computer
Hardware Reference
Library*

Guide to Operations

First Edition (Revised January 1983)

Changes are periodically made to the information herein; these changes will be incorporated in new editions of this publication.

Products are not stocked at the address below. Requests for copies of this product and for technical information about the system should be made to your authorized IBM Personal Computer dealer.

A Reader's Comment Form is provided at the back of this publication. If this form has been removed, address comment to IBM Corporation, Personal Computer, P.O. Box 1328-C Boca Raton, Florida 33432. IBM may use or distribute any of this information you supply in any way it believes appropriate without incurring any obligations whatever.

FEDERAL COMMUNICATIONS COMMISSION RADIO FREQUENCY INTERFERENCE STATEMENT

WARNING: This equipment has been certified to comply with the limits for a Class B computing device, pursuant to Subpart J of Part 15 of FCC rules. Only peripherals (computer input/output devices, terminals, printers, etc.) certified to comply with the Class B limits may be attached to this computer. Operation with non-certified peripherals is likely to result in interference to radio and TV reception.

INSTRUCTIONS TO USER

This equipment generates and uses radio frequency energy and if not installed and used properly, i.e., in strict accordance with the operating instructions, reference manuals, and the service manual, may cause interference to radio or television reception. It has been tested and found to comply with the limits for a Class B computing device pursuant to Subpart J of Part 15 of FCC Rules, which are designed to provide reasonable protection against such interference when operated in a residential installation.

If this equipment does cause interference to radio or television reception, which can be determined by turning the equipment off and on, the user is encouraged to try to correct the interference by one or more of the following measures:

- Reorient the receiving antenna.
- Relocate the equipment with respect to the receiver.
- Move the equipment away from the receiver.
- Plug the equipment into a different outlet so that equipment and receiver are on different branch circuits.
- Ensure that card mounting screws, attachment connector screws, and ground wires are tightly secured.
- Ensure that card slot covers are in place when no card is installed.

If necessary, consult your dealer service representative for additional suggestions.

The manufacturer is not responsible for any radio or TV interference caused by unauthorized modifications to this equipment. It is the responsibility of the user to correct such interference.

Notice: As sold by the manufacturer, this Prototype card does not require certification under the FCC's rules for Class B devices. The user is responsible for any interference to radio or TV reception which may be caused by a user-modified prototype card.

CAUTION: This product is equipped with a UL listed and CSA certified plug for user's safety. It is to be used in conjunction with a properly grounded 115 VAC receptacle to avoid electrical shock.

Notes:

Preface

The Guide to Operations introduces you to the IBM Personal Computer. If you will be setting up, using, or writing programs for the Personal Computer, this publication is for you. It has six sections.

Section 1, 'Introduction,' is an overview of some of the configurations, hardware, and software that is available.

Section 2, 'Setup,' directs you from installation through testing of the Personal Computer.

Section 3, 'Operations,' introduces you to the IBM Personal Computer. If you are a newcomer or an experienced operator, this section will become a ready reference. You will have instructions about the displays, printer, keyboard, diskettes, and language.

Section 4, 'Problem Determination Procedures.' The easiest and quickest way to check your system is to follow this procedure. It can be used to verify the proper operation, or determine where your problem is located.

Section 5, 'Options,' any additions to your unit will have various information that should be inserted in this section.

Section 6, 'Relocate,' as the name implies, you are moving the system. Recommendations for you to follow in order to move the unit(s) and prevent damage to them.

There are protruding tabs you may use to find the section you are looking for. Each section has a content page. The content page lists the chapters in the section and has bleeder tabs that you can use to get to that chapter quickly.

Notes:

CONTENTS

SECTION 1. INTRODUCTION	1-1
Introduction	1-3
Configuration Examples	1-4
Option Examples	1-6
SECTION 2. SETUP	2-1
Cabling Your IBM Personal Computer	2-3
Mini Power-On Self Test	2-7
Rear Panel Reference	2-9
Component Arrangement	2-11
Keyboard and Display Adjustment	2-12
Power-On Self Test (POST)	2-14
SECTION 3. OPERATIONS	3-1
Introduction	3-5
Getting Your IBM Personal Computer Ready	3-1
IBM Monochrome Display	3-1
Controls	3-1
IBM Color Display	3-3
Controls	3-3
Vertical Hold Adjustment	3-5
Vertical Size Adjustment	3-6
Keyboard	3-1
BASIC Layout and Usage	3-2
DOS Layout and Usage	3-9
IBM Printers	3-1
Introduction	3-1
Printer Power Switch	3-2
Printer Lights	3-3
Printer Control Buttons	3-4
Ribbon Cartridge Installation	3-5
Forms Installation	3-8
Top of Page Setting	3-13
Forms Thickness Control	3-14
Left Margin Adjustment	3-15
Printer Self-Test	3-16
IBM 80 CPS Matrix/Graphics Printer Modes	3-18
Printer Control Codes for IBM 80 CPS Matrix Printer ...	3-19

Matrix Printer Control and Character Chart with ASCII Decimal Value	3-32
Graphics Printer Control and Character Chart with ASCII Decimal Value Set 1	3-34
Graphics Printer Control and Character Chart with ASCII Decimal Value Set 2	3-36
Using DOS	3-1
Introduction	3-3
Our Notation	3-4
Starting DOS	3-5
If Your Computer Is Off	3-6
If Your Computer Is On	3-7
Telling DOS the Date	3-8
Telling DOS the Time	3-10
The DOS Prompt	3-11
Changing the Default Drive	3-13
Controlling DOS	3-14
Characters That Look Alike - “O’s” and “0’s” (zero), “1’s” and “L’s”	3-14
The Spacebar	3-15
The Shift and Caps Lock Keys	3-16
To Enter a Command	3-17
To Stop a Command	3-17
To Correct a Typing Mistake	3-18
To Stop the Screen Long Enough to Read It	3-19
To Print What Is On the Screen	3-19
To Print Whatever You Type	3-20
To Start DOS Again	3-20
About Diskettes	3-21
Tracks, Bytes, and Sectors	3-22
Careful Does It	3-24
Write-Protect Notch	3-25
An Important Exercise: Backing Up Your DOS	
Diskette	3-26
Before You Begin	3-26
If You Have One Drive	3-27
If You Have Two Drives	3-31
What’s on the DOS Diskette?	3-34
Files and Filenames	3-35
Global Filename Characters	3-39
An Exercise: Listing the DOS Diskette Files	3-42
DOS Diskette Files	3-44
Things You Can Do with DOS	3-45
Summary of Commands	3-45

FORMAT - Getting a Diskette Ready to Be Used	3-48
Before You Begin	3-49
If You Want DOS on Your Diskette	3-49
If You Do Not Want DOS on Your Diskette	3-51
Formatting Several Diskettes	3-51
DIR - Finding Out What Is on a Diskette	3-53
Before You Begin	3-53
To List All the Files	3-54
To List One File	3-55
DISKCOPY - Backing Up a Diskette	3-57
Before You Begin	3-57
Protecting Your Original Diskette	3-58
Backing Up with One Drive	3-59
Backing Up with Two Drives	3-61
COPY - Backing Up One File	3-64
Before You Begin	3-66
Copying a File to the Same Diskette	3-66
Copying a File to Another Diskette Using	
One Drive	3-67
Copying a File to Another Diskette Using	
Two Drives	3-71
TYPE - Displaying What Is in a File	3-73
Before You Begin	3-73
Here's How You Do It	3-73
RENAME - Changing a File's Name	3-75
Before You Begin	3-75
ERASE - Removing a File from a Diskette	3-78
Before You Begin	3-78
Global Filename Characters	3-80
MODE - Shifting the Display on the Screen	3-81
Before You Begin	3-81
Shift Right	3-81
Helps and Hints	3-83
Summary	3-85
Using BASIC	3-1
Introduction	3-3
Starting BASIC	3-5
For Cassette BASIC	3-5
If Your Computer Is Off	3-5
If Your Computer Is On	3-5
For Disk BASIC	3-6
For Advanced BASIC	3-6
The BASIC Startup Screen	3-7
The BASIC Prompt	3-7
Shifting the Display on the Screen	3-8

Returning to DOS	3-9
Several BASIC Commands	3-9
Some Keys You Will Use With BASIC	3-10
Function Keys	3-10
Running a BASIC Program	3-11
Running the SAMPLES Program	3-12
For Choices A, B, C, H, and I	3-14
For Choices D, E, F, G, and J (and the others too)	3-14
Running the COMM Program	3-16
COMM Program Choices	3-18
Running a BASIC Program on Another Diskette	3-19
With One Diskette Drive	3-20
With Two Diskette Drives	3-21
If You've Forgotten the File's Name	3-21
Entering Your Own BASIC Program	3-23
Storing Your BASIC Program	3-25
Changing Your BASIC Program	3-25
Finding Out What the Statements Are	3-26
Retyping	3-27
The EDIT Command	3-28
Adding a Statement	3-29
Removing a Statement	3-30
Summary	3-31

SECTION 4. PROBLEM DETERMINATION

PROCEDURES	4-1
Introduction	4-3
Checking Electrical Connections	4-5
Power-On Self Test	4-8
Error Examples	4-11
Diagnostic Testing	4-15
IBM Printer Problem Determination Procedures	4-66
IBM Color Display Problem Determination Procedures	4-69

SECTION 5. OPTIONS..... 5-1

SECTION 6. RELOCATE	6-1
Physical Preparation of the System	6-3
Short Distance Relocate	6-8
Long Distance Relocate for System and Expansion Unit(s)	6-9
Long Distance Relocate for Keyboard	6-10
Long Distance Relocate for IBM Monochrome or Color Display	6-11
Long Distance Relocate for IBM 80 CPS Matrix/Graphics Printer	6-12
Setup At New Location	6-13
 GLOSSARY	 Glossary 1
 INDEX	 X-1

Notes:

SECTION 1. INTRODUCTION

Contents

Introduction	1-3
Configuration Examples	1-4
Option Examples	1-6

Notes:

Introduction

The basic IBM Personal Computer consists of a system unit and keyboard. You may add a display, printer, expansion unit, additional memory, and other options to expand your system to meet your particular needs.

The system unit is the central part of your Personal Computer and supports a variety of options.

The keyboard, which is the primary input to the system, attaches to the system unit with a six foot coiled cable. The keyboard is divided into three major sections: the typewriter area, the numeric keypad and the function keys.

The IBM 80 CPS Matrix/Graphics Printer provides bidirectional printing, in several character sizes on single- or multi-part forms.

The expansion unit provides space for additional options to be attached to your IBM Personal Computer.

The IBM Personal Computer supports the attachment of the IBM Monochrome Display and IBM Color Display plus a variety of display devices either color or black and white.

The non-IBM devices in this manual are for illustration only, and their use here does not constitute a recommendation or an endorsement by IBM. Selection, interconnection, and use of another manufacturer's device, are the sole responsibility of the customer.

Configuration Examples

IBM Monochrome Display

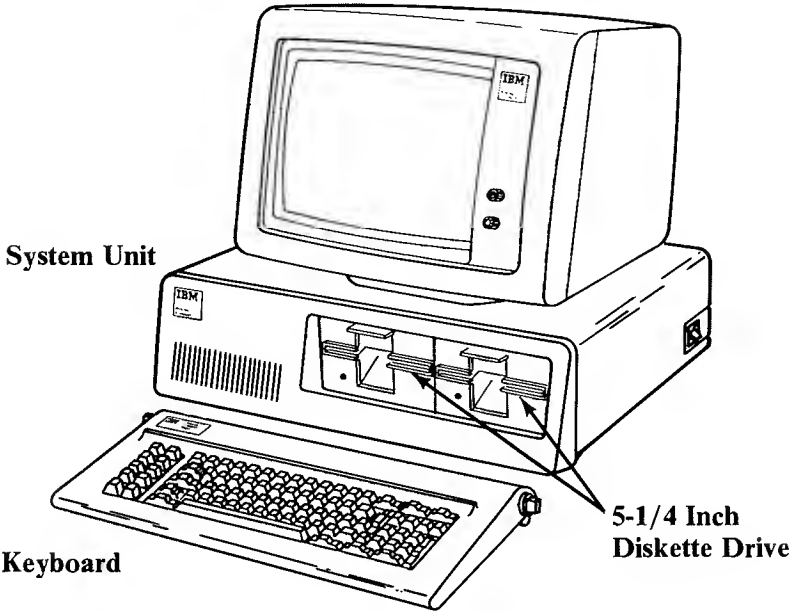

IBM 80 CPS Matrix/Graphics Printer

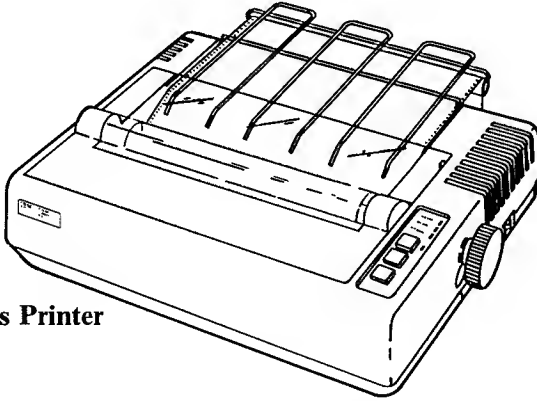

This example shows the system unit, keyboard, IBM Monochrome Display, and IBM 80 CPS Matrix/Graphics Printer. Two 5-1/4 inch diskette drive units are used to store programs and data.

System Unit

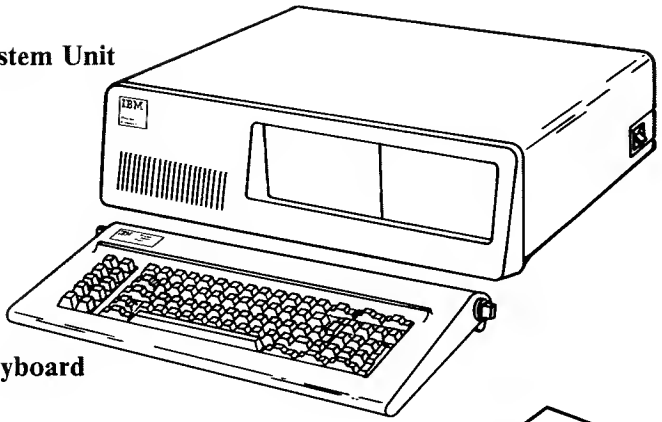

Keyboard

**Cassette Recorder
(Supplied by User)**

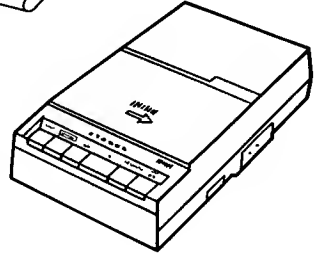

This example shows the system unit, keyboard, and cassette recorder. You can use your cassette recorder for the storage of programs and data.

Option Examples

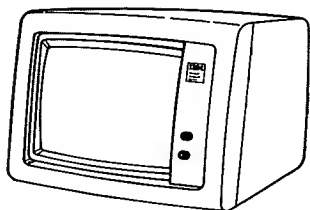

IBM Monochrome Display

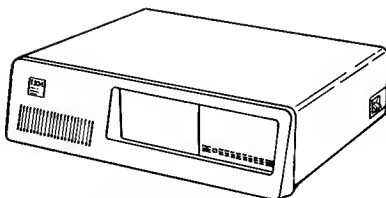

Expansion Unit

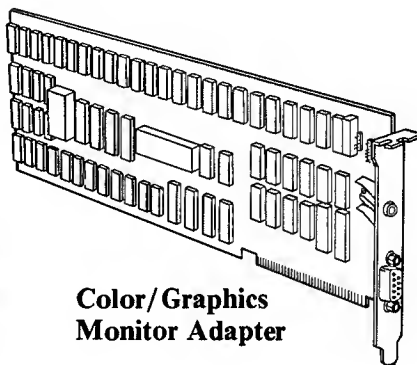

**Color/Graphics
Monitor Adapter**

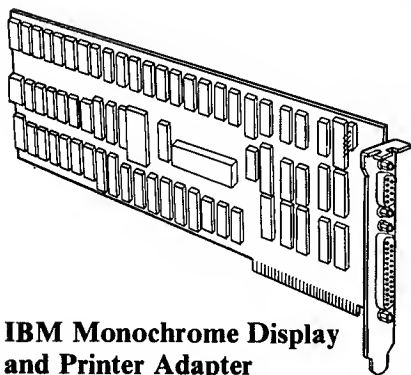

**IBM Monochrome Display
and Printer Adapter**

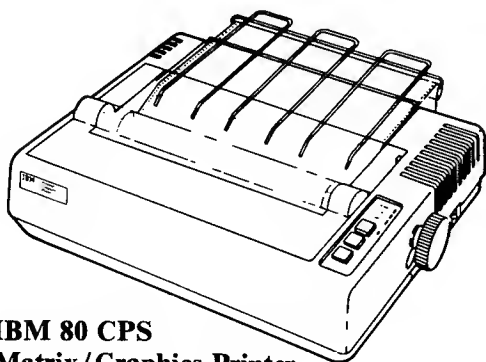

**IBM 80 CPS
Matrix/Graphics Printer**

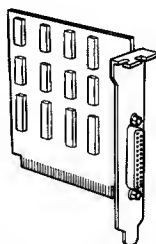

Printer Adapter

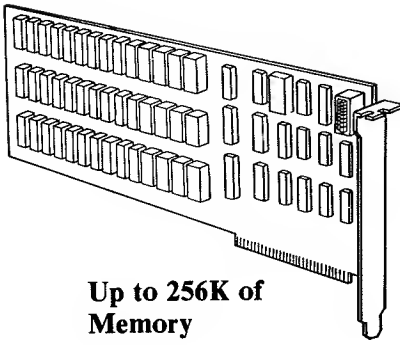

**Up to 256K of
Memory**

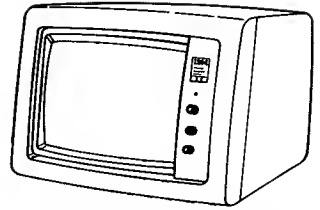

IBM Color Display

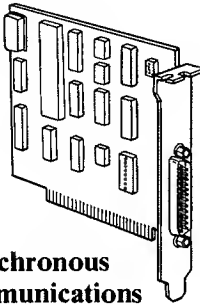

**Asynchronous
Communications
Adapter**

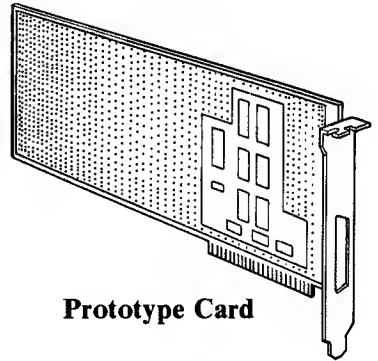

Prototype Card

Notes:

SECTION 2. SETUP

Contents

Cabling Your IBM Personal Computer	2-3
Mini Power-On Self Test	2-7
Rear Panel Reference	2-9
Component Arrangement	2-11
Keyboard and Display Adjustment	2-12
Power-On Self Test (POST)	2-14

Notes:

Cabling Your IBM Personal Computer

1. If your Personal Computer came with a 5-1/4 inch Diskette Drive installed in the system unit, remove the shipping cardboard.

System Unit

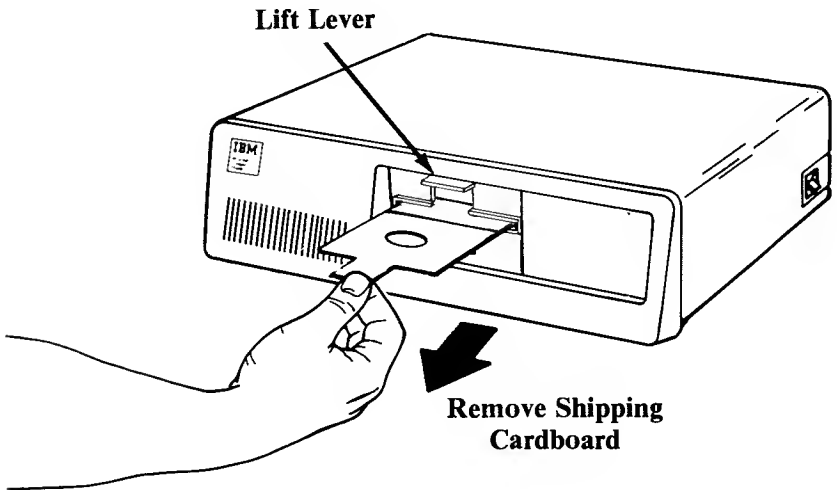
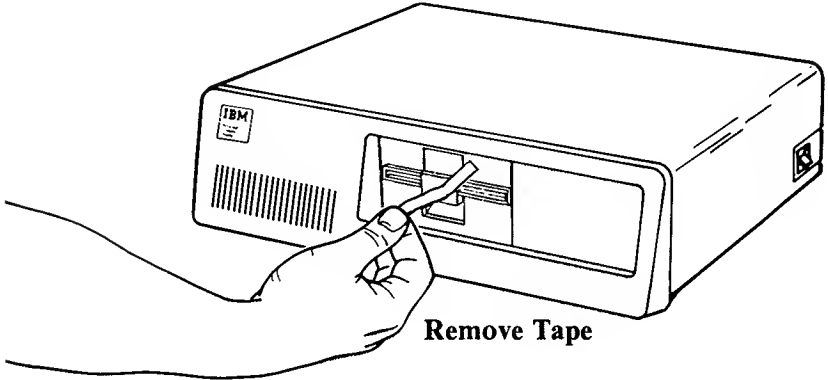

2. Place the system unit on the work area in the position as shown.

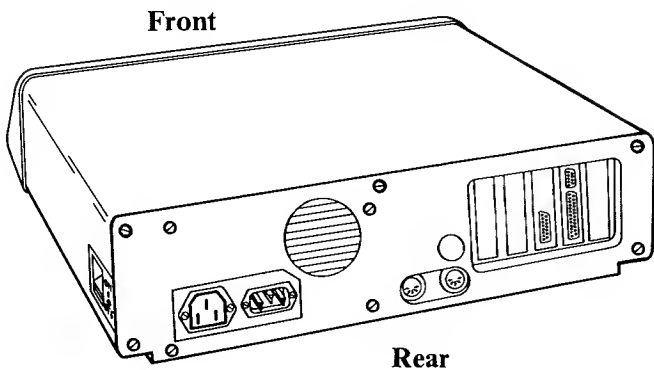

3. Place the keyboard next to the system unit and connect the cable as shown.

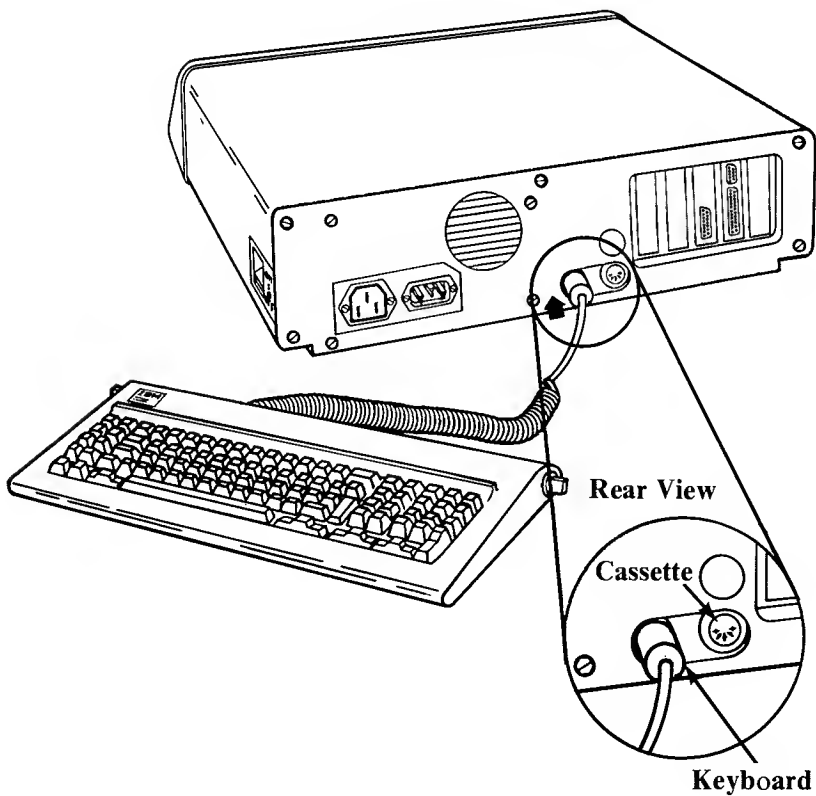

4. Set the system unit's Power switch to Off.

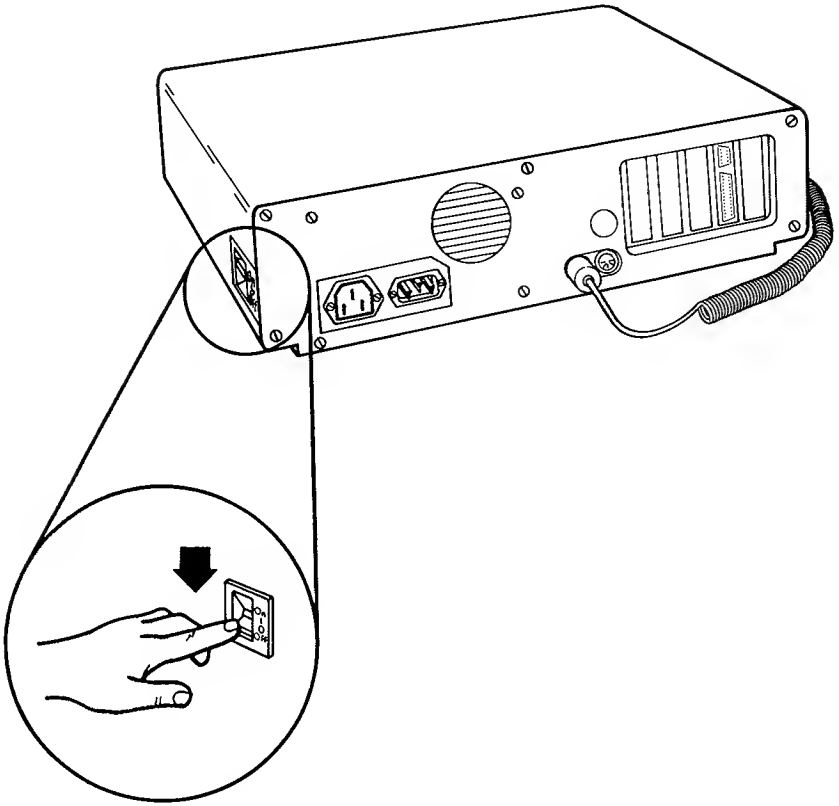

5. Connect the system unit's power cord to the system unit, then to the wall outlet.

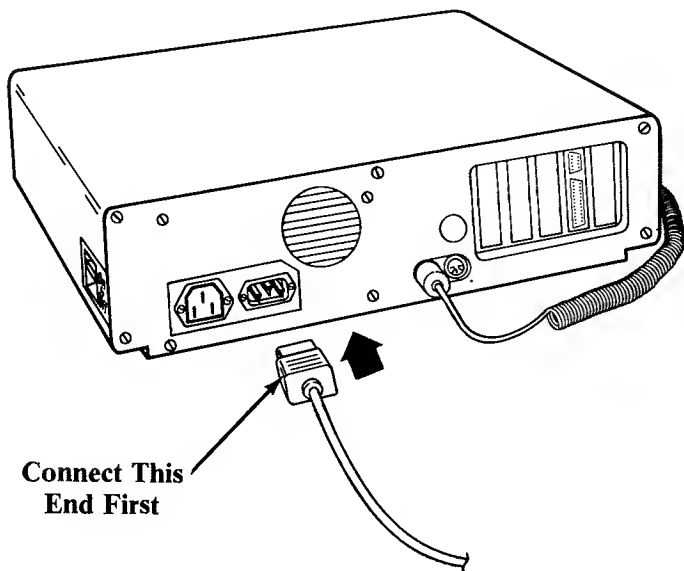

CAUTION: Connect to a properly grounded 115 Vac receptacle.

Mini Power-On Self Test

6. Set the system unit's Power switch to On. You should hear one short beep after the memory is checked. This will take between 3 and 90 seconds depending on the amount of memory installed.

If you have a diskette drive installed, it is normal to hear motor noise and see the in-use light for a short period of time.

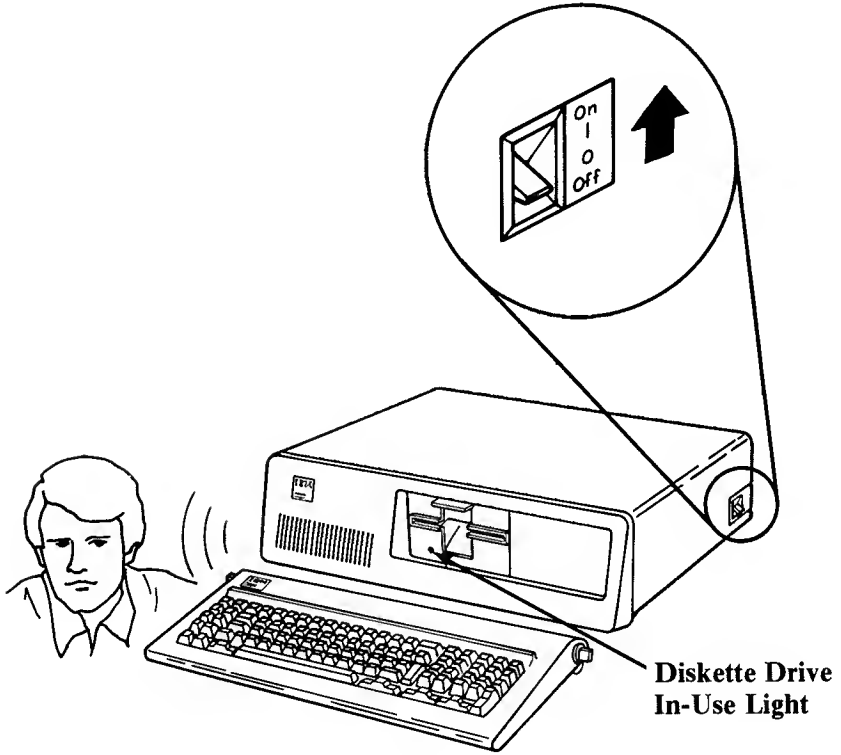

If you heard one short beep, your system unit has completed the Mini Power-On Self Test.

If you heard nothing or anything other than the short beep and the diskette drive, return your IBM Personal Computer to your place of purchase.

If you have any options you would like to install, go to Section 5, "Options." You may save time if you follow the sequence listed below when installing your options.

- 16KB Memory Expansion Kit
- 5-1/4 inch Diskette Drive(s)
- All other Option Adapter(s)

When you are finished, return to this section and continue.

Rear Panel Reference

7. Use the reference diagram below and connect all of the cables and cords.

If you have an expansion unit connected to your Personal Computer, refer to Section 5, "Options" and locate the IBM Personal Computer Expansion Unit Option Instruction to cable the expansion unit to the system unit.

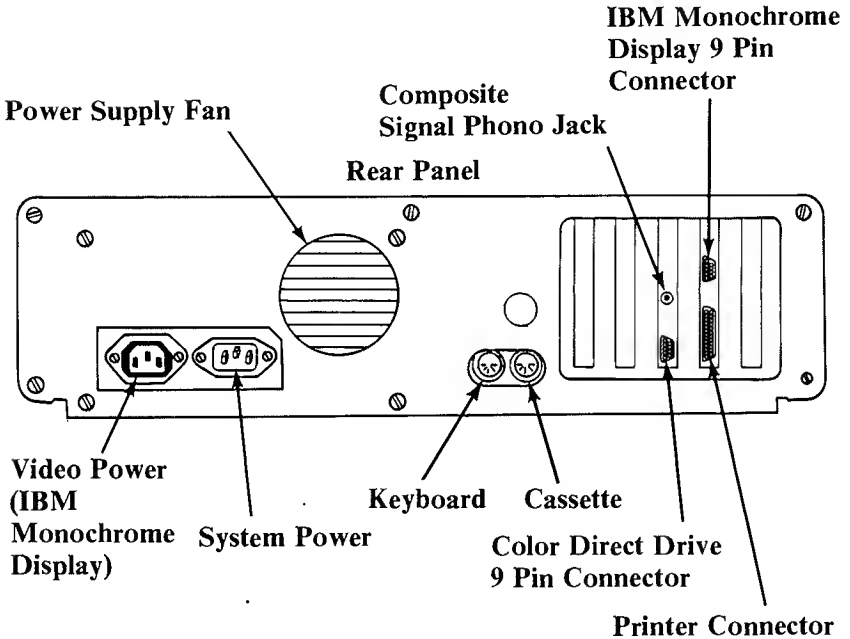

Before going to Step 8, read the note below.

Note: If you are using a home television or other display, you could experience data errors while using the 5-1/4 inch Diskette Drive. This problem is easily cured by moving the television or display at least 12 inches (35 cm) away from your IBM Personal Computer.

- 8.** If you have an expansion unit connected to your IBM Personal Computer, plug the expansion unit's power cord into a properly grounded 115 Vac receptacle.

Component Arrangement

- 9. Position your system components so you can use them (TV should be 12 inches (35 cm) from the diskette drive). Two of the more common arrangements are as follows.

IBM Monochrome Display

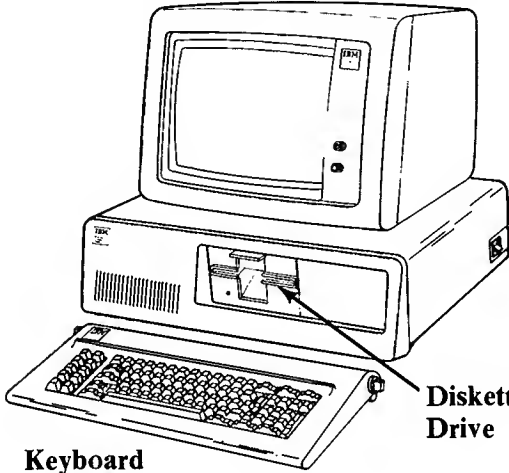

Keyboard

Diskette Drive

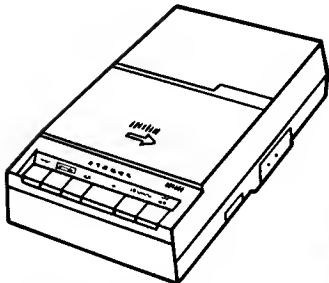

**Cassette Recorder
(Supplied by User)**

System Unit

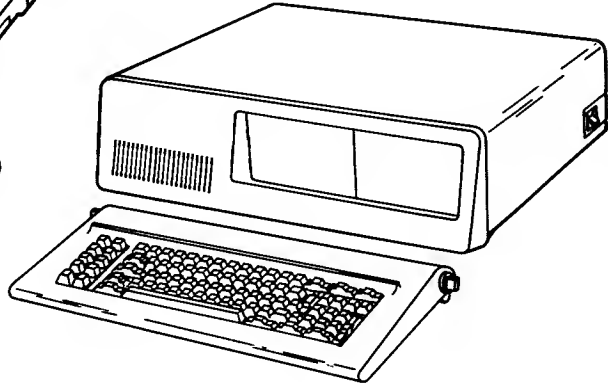

Keyboard and Display Adjustment

- 10.** The keyboard has adjustable tilt positions for typing comfort.

WARNING: Hold the keyboard when changing positions.

There is one adjustable leg handle at each end of keyboard.

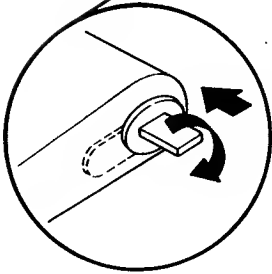
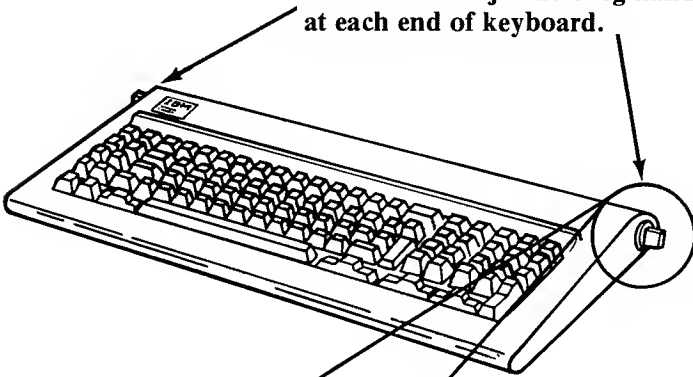

Level Position
Firmly push in the adjustable leg handles and turn.

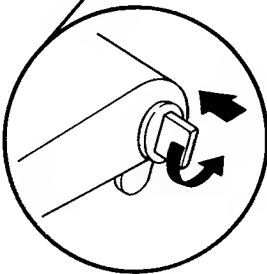

Tilt Position 1
Firmly push in the adjustable leg handles and turn.

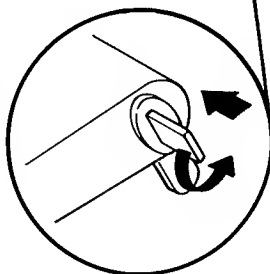

Tilt Position 2
Tilt Position 2 may not be available on your keyboard.

11. Turn the display or television contrast and brightness controls fully clockwise.

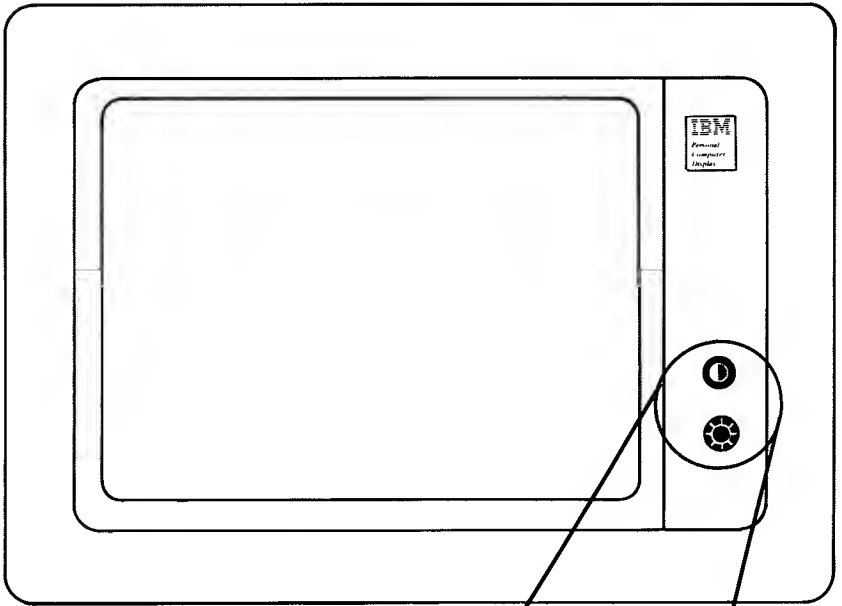

**IBM Monochrome
Display**

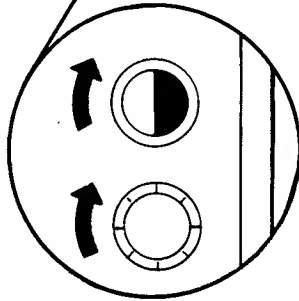

Your new IBM Personal Computer is ready for a Power-On Self Test.

Power-On Self Test (POST)

If you have an expansion unit attached to your Personal Computer, the expansion unit must always be turned on first unless otherwise indicated.

When you first set the system unit's Power switch to On a power-on self test (POST) occurs. The POST takes 3 to 90 seconds depending on the amount of memory installed.

- 12.** Set the Power switch on the expansion unit (if attached) to On.
- 13.** Set the Power switch on the system unit to On.
There will normally be three responses:
 - a. The cursor will appear on the screen in approximately 4 seconds.
 - b. One short beep will be heard after the memory is tested.
 - c. The IBM Personal Computer Message will appear on the screen.

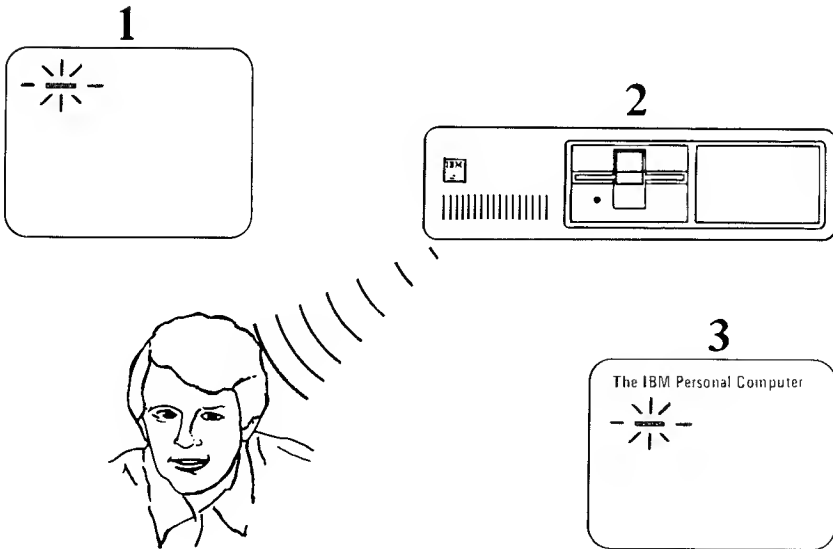

Note: These three responses tell you that the POST has successfully completed. Other information will appear on the screen but this is not important at this time. If you have diskette drive(s) and/or a printer (that you powered on), you will also hear and see responses from these; ignore these responses.

If the responses were incorrect, go to Section 4, "Problem Determination Procedures."

If the responses were correct, go to Step 13.

- 14.** Adjust contrast and brightness controls for eye comfort.

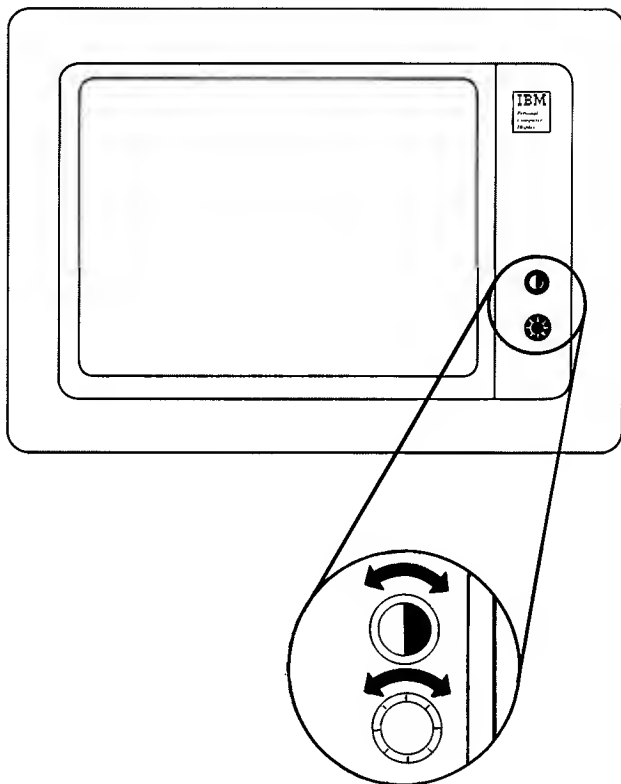

- 15.** Get the diskette or cassette labeled “Diagnostics” from the rear cover of this manual.

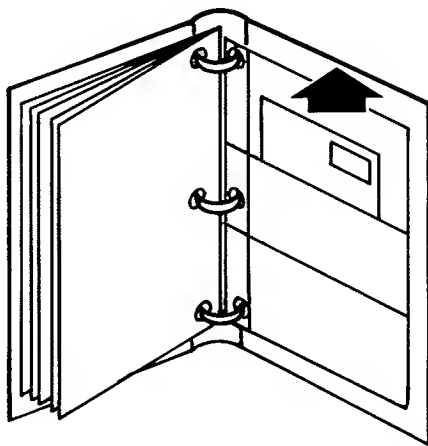

16. Loading Diskette Diagnostics

Note: If you are using the cassette, go to Step 17.

- A. Set the system unit's Power switch to Off.
- B. Lift the load lever.
- C. Insert the diskette as shown until the rear stop is felt.
- D. Push the load lever down and it will latch closed.
- E. Set the system unit's Power switch to On.

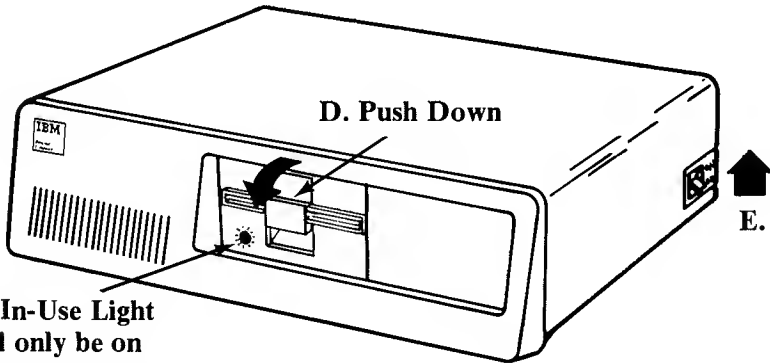
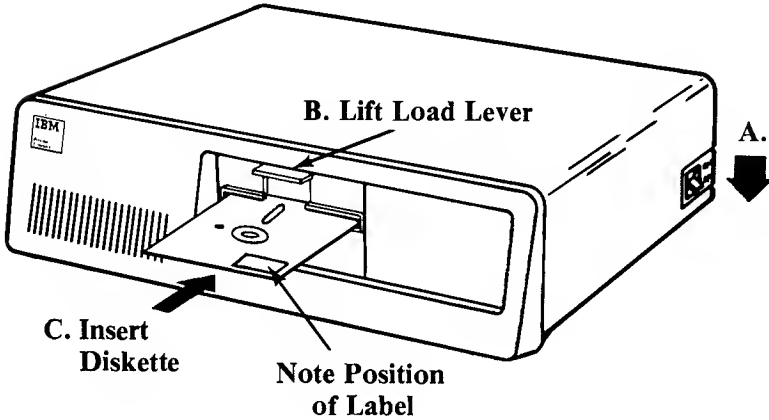

If you are using a home television or other displays with your IBM Personal Computer, and the information on the screen is shifted to the left or right, as in the example below, press Function key



to move the information to the right, or Function key  to move the information to the left.

e IBM Personal Computer DIAGNOSTICS
rsion xxx (C) Copyright IBM Corp xxxx, xxxx

LECT AN OPTION

- RUN DIAGNOSTIC ROUTINES
- FORMAT DISKETTE
- COPY DISKETTE
- PREPARE FIXED DISK FOR RELOCATION
- EXIT TO SYSTEM DISKETTE

SERT DIAGNOSTIC DISKETTE IN DRIVE
AND ENTER THE ACTION DESIRED

—

If the information on your screen is not centered, center it at this time and go to Step 20.

17. Loading Cassette Diagnostics

If you are using a cassette recorder to test your system, follow the procedures below.

1. Read the cassette recorder's user manual before continuing.
2. Insert the Diagnostics cassette.
3. Rewind the cassette to the beginning.
4. Set the system unit's Power switch to On.
5. Turn the volume on the cassette recorder to high.
6. Press Play on the cassette recorder.
7. Type load"ldcass.

8. Press  .

9. Ensure your cassette is turning.
10. Wait for ldcass .B to appear on the screen, then wait for Ok to appear on the screen.
11. Type RUN.

12. Press  .

13. Wait for "THE INSTALL DEVICES ARE" frame to appear on the screen (approximately 90 seconds).

If you are using a home television or other displays with your IBM Personal Computer, and the information on the screen is shifted to the left or right, as in the example below, press Function key



to move the information to the right, or Function key  to move the information to the left.

INSTALLED DEVICES ARE

EM BOARD

B MEMORY

BOARD

MOCHROME & PRINTER ADAPTER

MONITOR/GRAPHICS ADAPTER



IS THE LIST CORRECT (Y/N) ?

If the information on your screen is not centered, center it this time and continue.

- 18.** When the cassette is loaded, the screen will be similar to this figure.

**THE INSTALLED DEVICES ARE
SYSTEM BOARD
128KB MEMORY
KEYBOARD
MONOCHROME & PRINTER ADAPTER
COLOR/GRAPHICS ADAPTER**

IS THE LIST CORRECT (Y/N)?

19. Press  then . This screen will appear.

SYSTEM CHECKOUT

- 0 - RUN TESTS ONE TIME**
- 1 - RUN TESTS MULTIPLE TIMES**
- 2 - LOG UTILITIES**
- 9 - EXIT DIAGNOSTIC ROUTINES**

ENTER THE ACTION DESIRED

?

- 20.** Using the Diagnostics diskette compare the screen; if the screen is not similar go to Section 4, "Problem Determination Procedures."

The IBM Personal Computer DIAGNOSTICS

Version xxx (C) Copyright IBM Corp xxxx

SELECT AN OPTION

0 - RUN DIAGNOSTIC ROUTINES

1 - FORMAT DISKETTE



2 - COPY DISKETTE

3 - PREPARE FIXED DISK FOR RELOCATION

9 - EXIT TO SYSTEM DISKETTE

**INSERT DIAGNOSTIC DISKETTE IN DRIVE
A AND ENTER THE ACTION DESIRED**

—

- 21.** Press  then  .

22. Summary

This completes your system mini-test. Return the Diagnostics cassette or diskette to the back of this manual.

IBM recommends you perform a complete system checkout whenever you recable your system or install an option. The system checkout is in Section 4, "Problem Determination Procedures."

You are now ready to learn the fundamentals of your system. Go to Section 3, "Operations."

Notes:

SECTION 3. OPERATIONS

Contents

Introduction	3-5
Getting Your IBM Personal Computer Ready	3-1
IBM Monochrome Display	3-1
Controls	3-1
IBM Color Display	3-3
Controls	3-3
Vertical Hold Adjustment	3-5
Vertical Size Adjustment	3-6
Keyboard	3-1
BASIC Layout and Usage	3-2
DOS Layout and Usage	3-9
IBM Printers	3-1
Introduction	3-1
Printer Power Switch	3-2
Printer Lights	3-3
Printer Control Buttons	3-4
Ribbon Cartridge Installation	3-5
Forms Installation	3-8
Top of Page Setting	3-13
Forms Thickness Control	3-14
Left Margin Adjustment	3-15
Printer Self-Test	3-16
IBM 80 CPS Matrix/Graphics Printer Modes	3-18
Printer Control Codes for IBM 80 CPS Matrix Printer ...	3-19
Matrix Printer Control and Character Chart with ASCII Decimal Value	3-32
Graphics Printer Control and Character Chart with ASCII Decimal Value Set 1	3-34
Graphics Printer Control and Character Chart with ASCII Decimal Value Set 2	3-36
	Operations 3-1

Using DOS	3-1
Introduction	3-3
Our Notation	3-4
Starting DOS	3-5
If Your Computer Is Off	3-6
If Your Computer Is On	3-7
Telling DOS the Date	3-8
Telling DOS the Time	3-10
The DOS Prompt	3-11
Changing the Default Drive	3-13
Controlling DOS	3-14
Characters That Look Alike -	
“O’s” and “0’s” (zero), “1’s” and “L’s”	3-14
The Spacebar	3-15
The Shift and Caps Lock Keys	3-16
To Enter a Command	3-17
To Stop a Command	3-17
To Correct a Typing Mistake	3-18
To Stop the Screen Long Enough to Read It	3-19
To Print What Is On the Screen	3-19
To Print Whatever You Type	3-20
To Start DOS Again	3-20
About Diskettes	3-21
Tracks, Bytes, and Sectors	3-22
Careful Does It	3-24
Write-Protect Notch	3-25
An Important Exercise: Backing Up Your DOS	
Diskette	3-26
Before You Begin	3-26
If You Have One Drive	3-27
If You Have Two Drives	3-31
What’s on the DOS Diskette?	3-34
Files and Filenames	3-35
Global Filename Characters	3-39
An Exercise: Listing the DOS Diskette Files	3-42
DOS Diskette Files	3-44
Things You Can Do with DOS	3-45
Summary of Commands	3-45

FORMAT - Getting a Diskette Ready to Be Used	3-48
Before You Begin	3-49
If You Want DOS on Your Diskette	3-49
If You Do Not Want DOS on Your Diskette	3-51
Formatting Several Diskettes	3-51
DIR - Finding Out What Is on a Diskette	3-53
Before You Begin	3-53
To List All the Files	3-54
To List One File	3-55
DISKCOPY - Backing Up a Diskette	3-57
Before You Begin	3-57
Protecting Your Original Diskette	3-58
Backing Up with One Drive	3-59
Backing Up with Two Drives	3-61
COPY - Backing Up One File	3-64
Before You Begin	3-66
Copying a File to the Same Diskette	3-66
Copying a File to Another Diskette Using One Drive	3-67
Copying a File to Another Diskette Using Two Drives	3-71
TYPE - Displaying What Is in a File	3-73
Before You Begin	3-73
Here's How You Do It	3-73
RENAME - Changing a File's Name	3-75
Before You Begin	3-75
ERASE - Removing a File from a Diskette	3-78
Before You Begin	3-78
Global Filename Characters	3-80
MODE - Shifting the Display on the Screen	3-81
Before You Begin	3-81
Shift Right	3-81
Helps and Hints	3-83
Summary	3-85
Using BASIC	3-1
Introduction	3-3

Starting BASIC	3-5
For Cassette BASIC	3-5
If Your Computer Is Off	3-5
If Your Computer Is On	3-5
For Disk BASIC	3-6
For Advanced BASIC	3-6
The BASIC Startup Screen	3-7
The BASIC Prompt	3-7
Shifting the Display on the Screen	3-8
Returning to DOS	3-9
Several BASIC Commands	3-9
Some Keys You Will Use With BASIC	3-10
Function Keys	3-10
Running a BASIC Program	3-11
Running the SAMPLES Program	3-12
For Choices A, B, C, H, and I	3-14
For Choices D, E, F, G, and J (and the others too)	3-14
Running the COMM Program	3-16
COMM Program Choices	3-18
Running a BASIC Program on Another Diskette	3-19
With One Diskette Drive	3-20
With Two Diskette Drives	3-21
If You've Forgotten the File's Name	3-21
Entering Your Own BASIC Program	3-23
Storing Your BASIC Program	3-25
Changing Your BASIC Program	3-25
Finding Out What the Statements Are	3-26
Retyping	3-27
The EDIT Command	3-28
Adding a Statement	3-29
Removing a Statement	3-30
Summary	3-31

Introduction

Within this section are the instructions you need to start using your IBM Personal Computer. This section tells you how to get your computer ready and describes the power-on self test, or POST, which ensures your computer is ready for use. The controls and adjustments for the IBM Monochrome and Color Displays are discussed. This section also shows the layout of the keyboard and the use of each key.

If you have the IBM 80 CPS Matrix/Graphics Printer, this section will tell you what you need to know to use it correctly. You also will find charts for the ASCII control codes, character and symbol codes, and graphic codes.

If you purchased (DOS), the pages in this section explain how to use the most common DOS commands. In addition, you will be guided through the SAMPLES program, which is on the DOS diskette. Instructions are for the running of DOS.

The bleeder tabs down the right side of the pages will help you get to the information you want, quickly.

Notes:

Getting your IBM Personal Computer Ready

1. Turn display or TV contrast and brightness controls fully clockwise. (If your display has an On/Off control, set the control to On.)

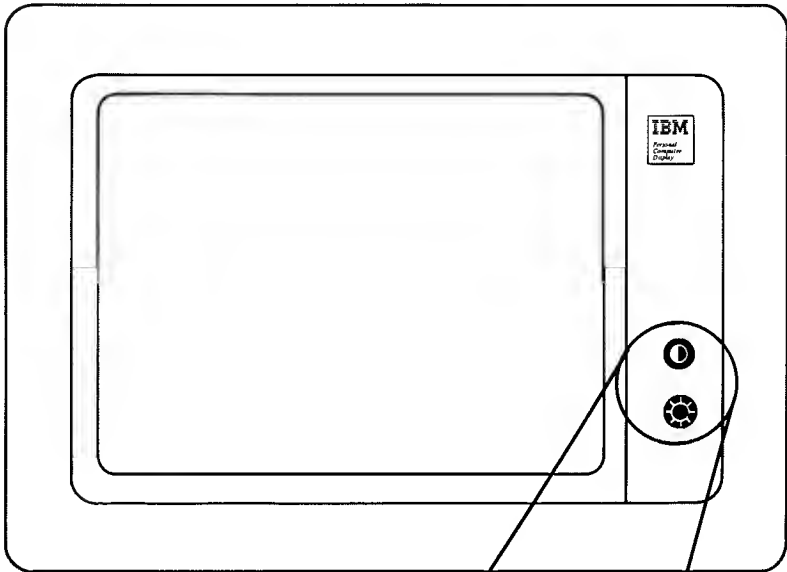

IBM Monochrome Display

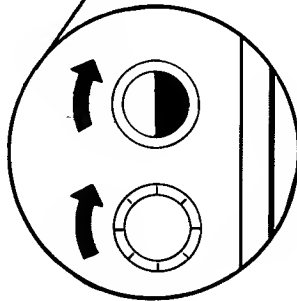

2. When you first set the system unit's Power switch to On, the power-on self test (POST) occurs. The time the POST takes (3 to 90 seconds) is determined by the amount of memory installed in your system unit.

Set the Power switch on the expansion unit (if attached) to On.

Set the Power switch on the system unit to On.

There will normally be three responses:

- The cursor will appear on the screen in approximately 4 seconds.
- One short beep will be heard after memory is tested.
- The IBM Personal Computer message will appear on the screen.

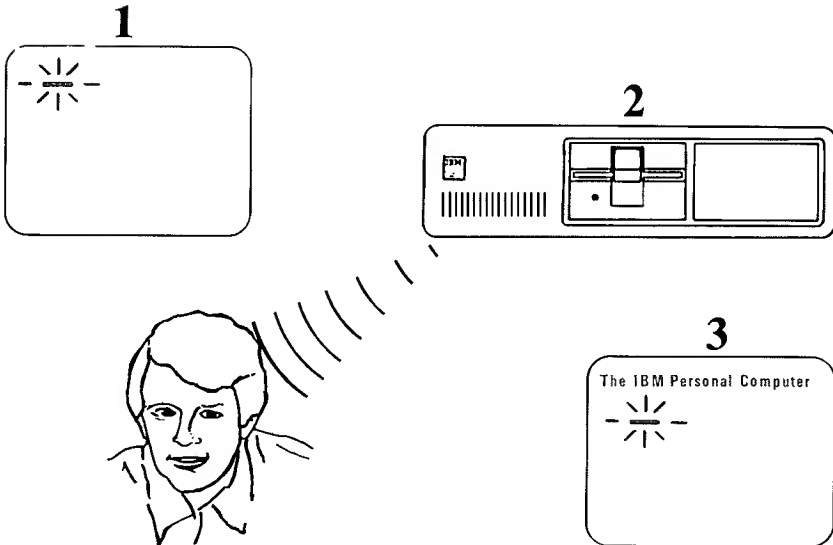

Note: These three responses tell you that the POST has successfully completed. Other information will appear on the screen and it is not important at this time. If you have a diskette drive and/or a printer (that you powered on), you will also hear and see responses from these; ignore these responses at this time.

If the responses were not correct, go to Section 4, "Problem Determination Procedures."

3. Adjust contrast and brightness controls for eye comfort.

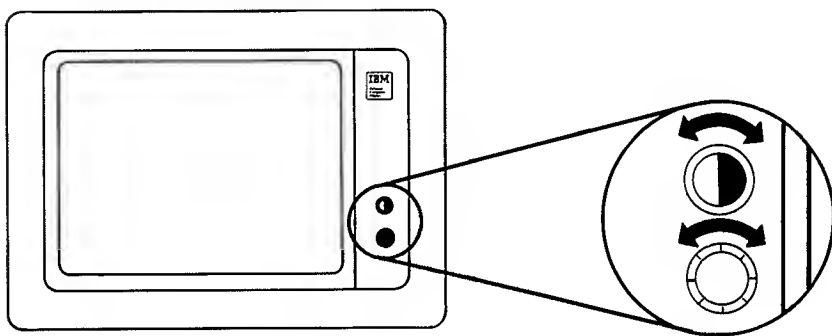

4. The screen should look similar to this figure. If this screen does not look similar, refer to Section 4, "Problem Determination Procedures."

The IBM Personal Computer Basic
Version X.XX Copyright IBM Corp. XXXX
XXXXXX Bytes Free
OK

1LIST 2RUN 3LOAD" 4SAVE 5CONT 6LPT1 '7TRON 8TROFF 9KEY 0SCREEN

IBM Monochrome Display

Controls

Adjust contrast and brightness controls for eye comfort.

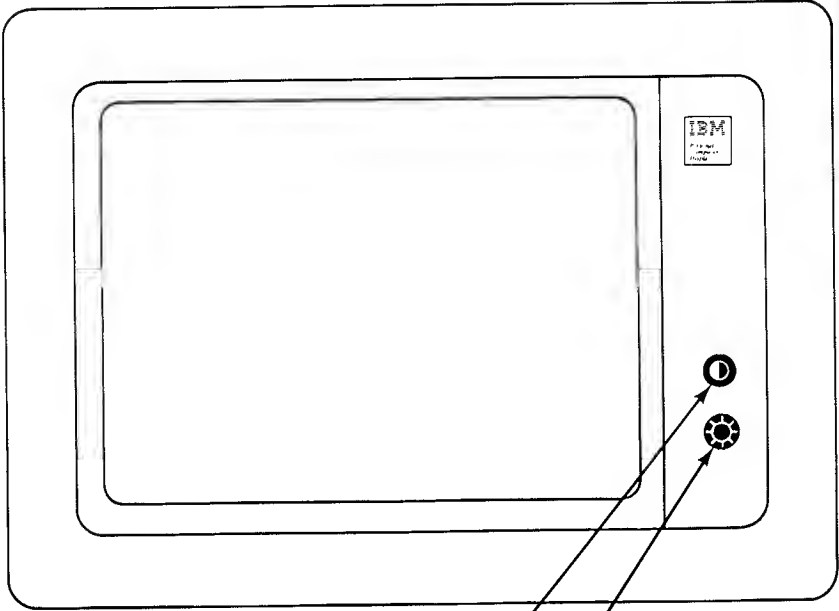

**Brightness
Control**



**Contrast
Control**



DISPLAYS

Notes:

IBM Color Display

Controls

The Power-On control applies power to the IBM Color Display when turned clockwise, and removes power when turned counterclockwise. The Power-On indicator lights when the display is on.

The Brightness control increases the brightness of the entire screen when turned clockwise, and decreases the brightness when turned counterclockwise.

The Contrast control increases the brightness of black, blue, green, cyan, red, magenta, brown, and white only, when turned clockwise, and decreases the brightness of these colors when turned counterclockwise.

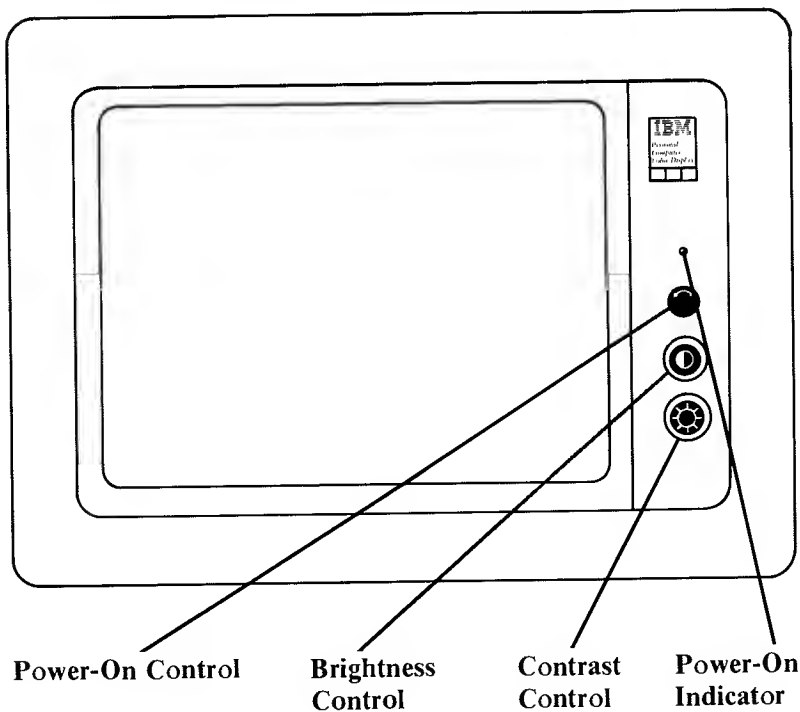

Notes:

Displays 3-4

Vertical Hold Adjustment

This adjustment is required only if your IBM Color Display has a vertical-hold problem (screen rolling top-to-bottom or bottom-to-top).

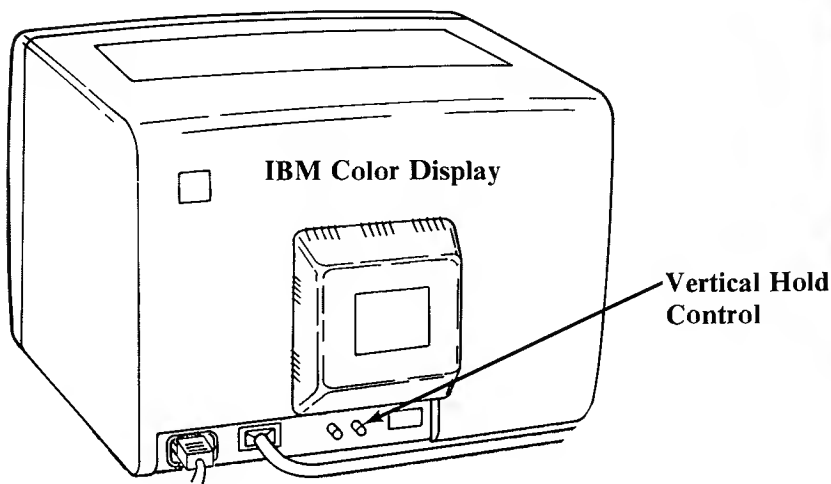

1. Set the system unit Power switch and the display Power switch to On.
2. Wait for POST to complete.
3. Turn the Vertical Hold control clockwise as far as it will go, then turn it counterclockwise until the screen stops rolling and is stable.

Vertical Size Adjustment

This adjustment is required only if the character size on your IBM Color Display is incorrect.

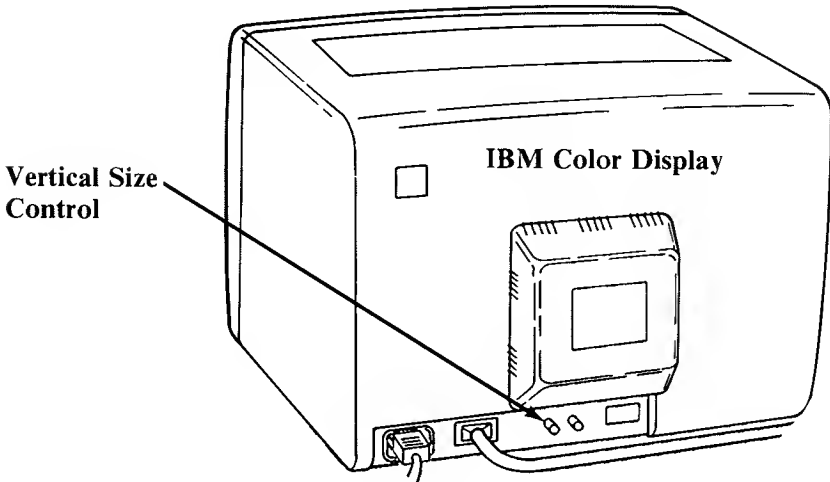

- 1.** Set the system unit's Power switch (and expansion unit's power switch, if attached) to Off.
- 2.** Set the display's Power switch to On.
- 3.** Turn the Brightness and Contrast controls fully clockwise.
- 4.** Turn the Vertical Size control fully counterclockwise. A black area should appear across the top and bottom of the screen.
- 5.** Turn the Vertical Size control clockwise until the black area at the top and bottom of the screen just disappears. If one of the black areas disappears before the other, continue to turn the control until the second black area is gone.
- 6.** Adjust the Brightness and Contrast controls for eye comfort.

Keyboard

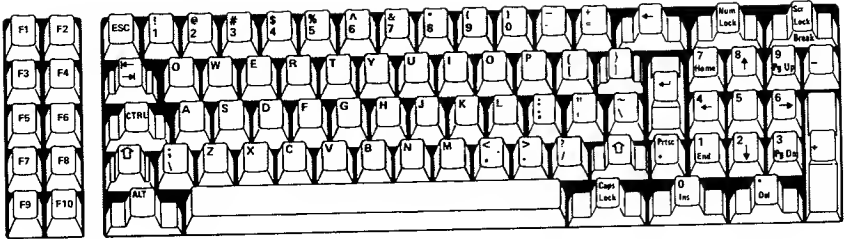

On the next few pages is a description of the IBM Personal Computer Keyboard. Take the time to read this information. Two points to remember:

- You cannot damage your IBM Personal Computer by pressing any key or combination of keys. You may not get the results you are looking for, but there is no way you can do any harm to any part of the computer, by pressing a key.
- Not all of the keys are used in every application. Different programs use different keys in different ways. Specific key usage is explained in the manual for whatever program you are using.



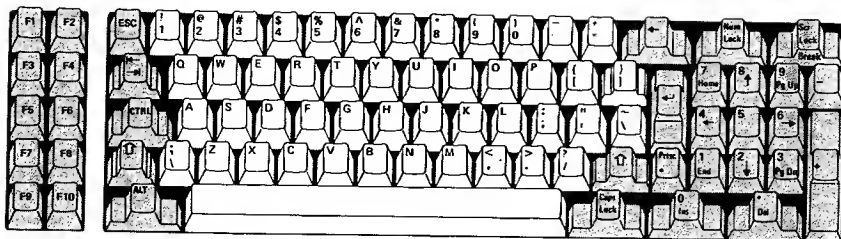

BASIC Keyboard Usage

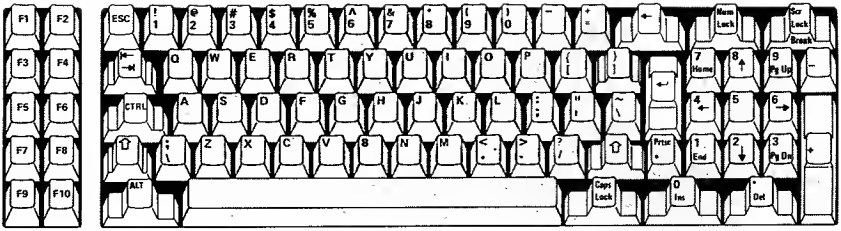

The unshaded keys are used the same as those on a normal typewriter.



The unshaded keys are used to aid you in writing, updating, and running programs.

Key	Description
ESC	Escape: clears the line that has the cursor from the screen; does not delete that line if it is already in a program.
 	TAB: performs a tab function similar to a typewriter. Tabs are set every 8 characters.
CTRL	Control: always used with another key to perform a command or function.
	Shift: changes lowercase letters to uppercase.
ALT	Alternate: used with alpha typing keys to enter BASIC keywords.
	Backspace: moves the cursor to the left and removes one character for each keystroke.
	Enter: moves the cursor from the last character on one line to the first character of the next line. Shows the logical end of a line.

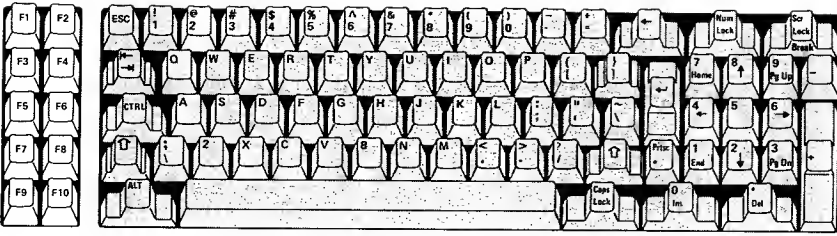

The unshaded keys are program function keys. They are used to make the system perform the commands listed below:

Key	Description
F1	LIST: displays the lines of your program on the screen.
F2	RUN: causes your program to begin execution from the beginning of the program.
F3	LOAD“: reads your program from auxiliary storage (e.g., cassette) and stores it in main memory.
F4	SAVE“: stores your program on auxiliary storage (e.g., cassette).
F5	CONT: restarts your program after you have interrupted it by a Stop or Ctrl Break.
F6	“LPT1”: transfers data from the screen to the printer.
F7	TRON (trace on): causes the line numbers of the program lines to be displayed as the lines are executed.
F8	TROFF (trace off): cancels trace on.
F9	KEY: used to change the function of other function keys.
F10	SCREEN: returns the program to character mode from graphics mode, and turns off color.

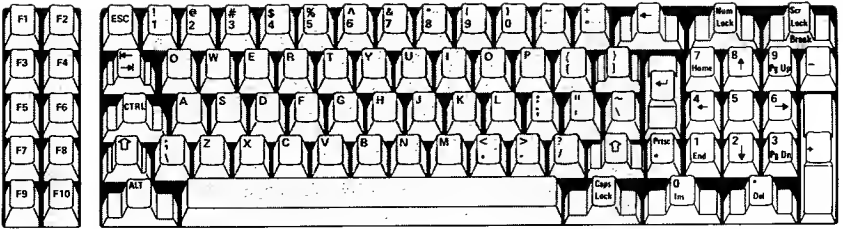

Num Lock means number lock, and is a toggle key; press once and the numeric keypad is activated. Press again and the numeric keypad is cancelled.

Key	Description
1 through 9	Num Lock activated 1 through 9 will be operative.
. Del	Decimal Point: used with the numeric keypad.
0 Ins	Zero: used with the numeric keypad.
-	Minus: used with the numeric keypad.
+	Plus: used with the numeric keypad.

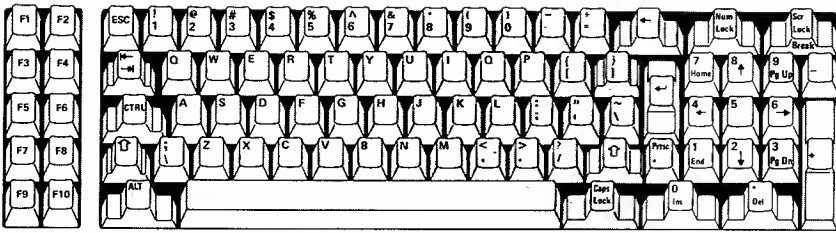

When Num Lock is pressed to cancel the numeric keypad, the following keys will be operative. The normal state of the Num Lock key is Off.

Key	Description
7 HOME	Home: moves the cursor to the first character of the top line of the screen.
8 ↑	Moves the cursor up one line each keystroke.
4 ←	Moves the cursor one character to the left each keystroke.
6 →	Moves the cursor one character to the right each keystroke.
2 ↓	Moves the cursor down one line for each keystroke.
1 END	End: Moves the cursor to the last character of the line.
. DEL	Delete: deletes the character at the cursor's position.
0 INS	Insert: sets the keyboard to the insert mode. Typed characters will be entered at the cursor's position, and all data will move to the right. Press Insert key again to leave insert mode.

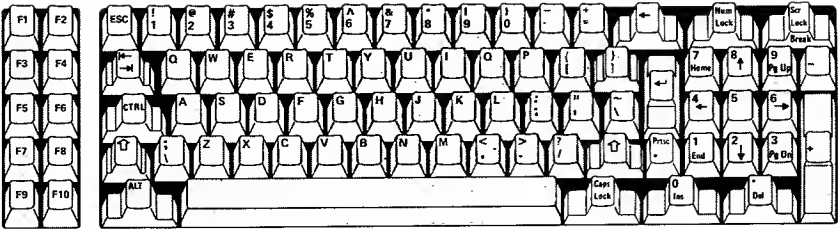

The unshaded keys will perform the following functions:

Key	Description
Caps Lock	This is a toggle key; pressing the key will cause letters to be in uppercase (capitals). Pressing the key again will return the letters to lowercase.
PrtSc	Print Screen: will print an asterisk (*). When pressed with the Shift key, it will print all data on the screen.
Scroll Lock	An inactive key.

KEYBOARD

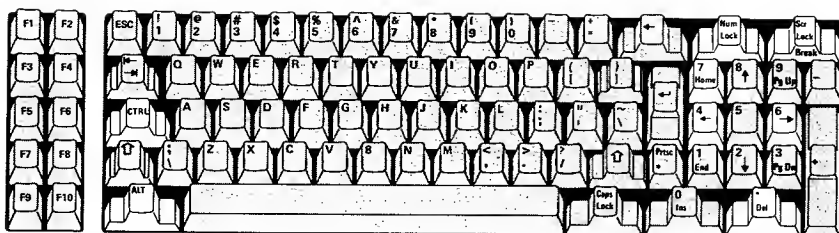

Below are examples of the Control and Alternate functions:

Ctrl + Scroll Lock = Break

This stops your program while it is running and identifies the line where the program stopped.

Ctrl + Num Lock = Pause

This stops your program. Press any key to continue.

Ctrl + /6 = Next Word

Moves the cursor to the next word on the line.

Ctrl + /4 = Previous Word

Moves the cursor to the previous word on the line.

Ctrl + Home = Clear Screen

Removes all information on the screen and moves the cursor to the upper left corner.

Ctrl + Alt + Del = System Reset

Holding the Ctrl and the Alt keys, then pressing the Del key, reloads your system or program diskette. (An error will appear if you have a data diskette loaded.)

DOS Keyboard Usage

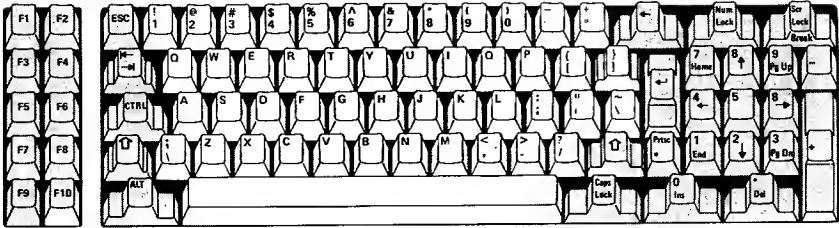

The unshaded keys are used the same as those on a normal typewriter.

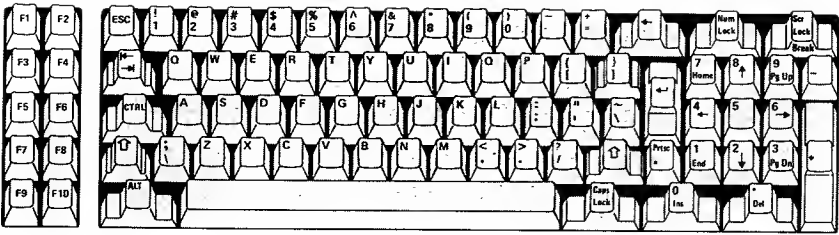

Key	Description
F1	Redisplays previously-entered line, a character at a time.
F2	Press F2 and a character. The screen will redisplay all of the previously-entered line up to the character you entered.
F3	Redisplays entire previously-entered line.
F4	Press F4 and a character. The screen will skip all of the characters in the previously-entered line up to the character you entered.
F5	Stores the currently displayed line for further editing.

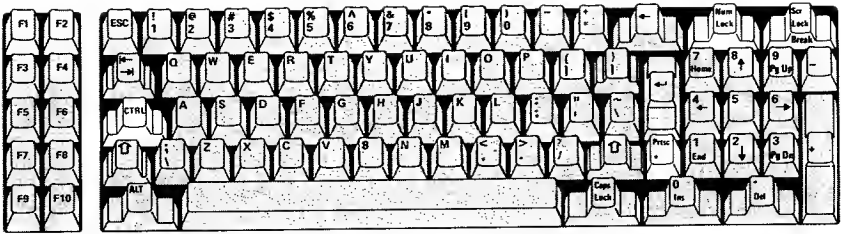

Below are examples of the Control functions.

Ctrl + Num Lock = Suspend

Suspends the operation of the system so you can read the screen. Press any key to continue.

Ctrl + PrtSc = Echo

Echoes and prints what you type and what the system displays until you press these keys again.

Ctrl + Scroll Lock/Break = Break

This stops your command program while it is running.

Notes:

IBM Printers

Introduction

This section describes the set-up, self-test, and operation of the IBM 80 CPS Matrix Printer and the IBM 80 CPS Graphics Printer.

Both printers are capable of bidirectional printing on several character sizes, using single or multi-part forms in widths of 4 to 10 inches.

The nameplate (logo) on the front identifies which printer you have.

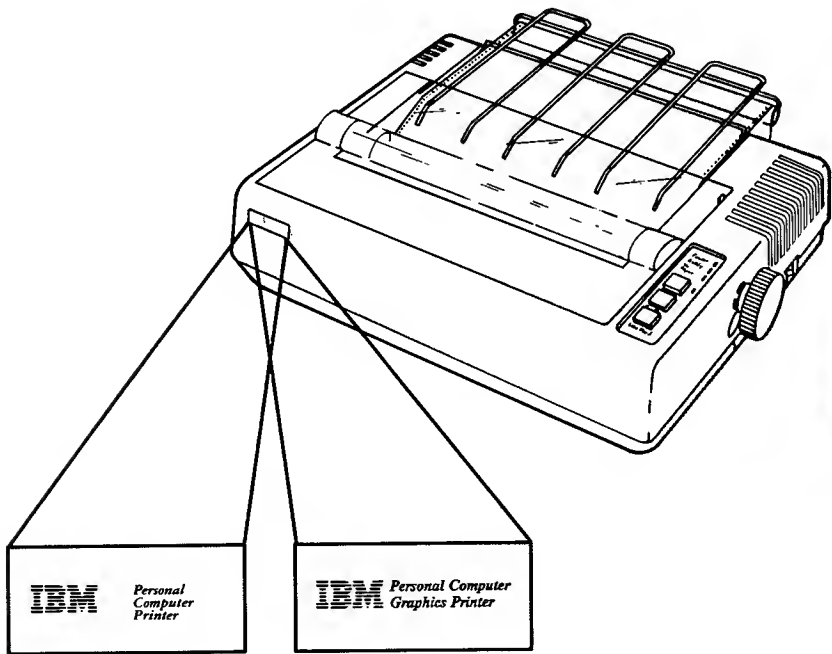

Note: The Samples Calendar program will not print out correctly on the IBM 80 CPS Graphics Printer.

Printer Power Switch

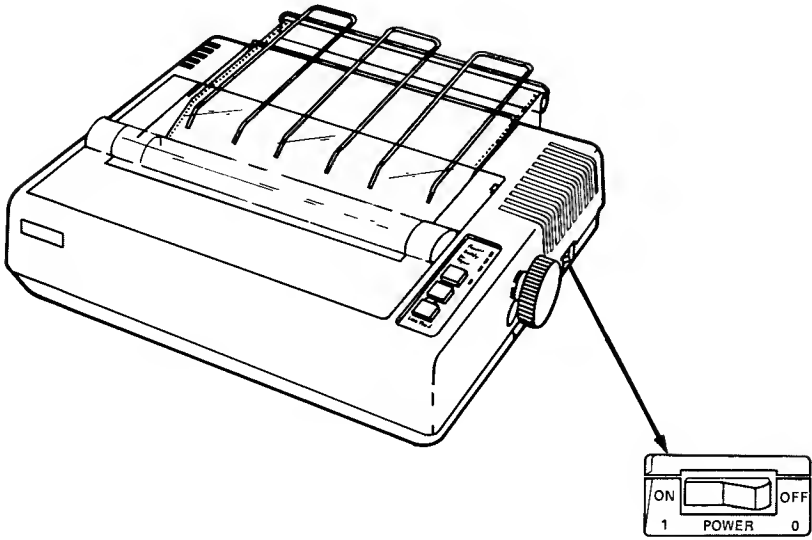

Set the Power switch to ON.

Printer Lights

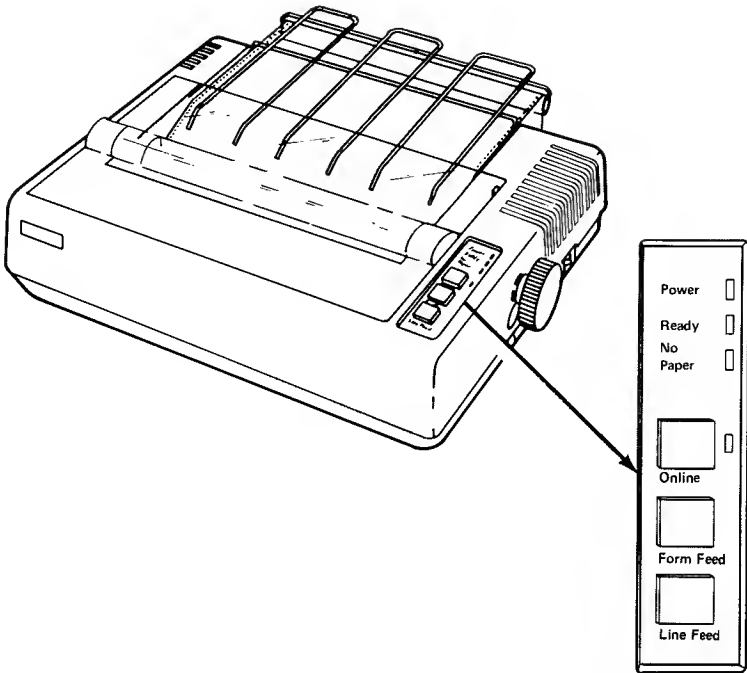

- 1. Power** light is on when the printer power is on.
- 2. Ready** light is on when the printer is ready to receive information for printing. This light will turn on and off as the printer receives information from the computer.
- 3. No Paper** light is on when the printer is out of paper or near the end. A beeping sound will also be heard from the printer.
- 4. Online** light is on when the printer is prepared to receive information.

Printer Control Buttons

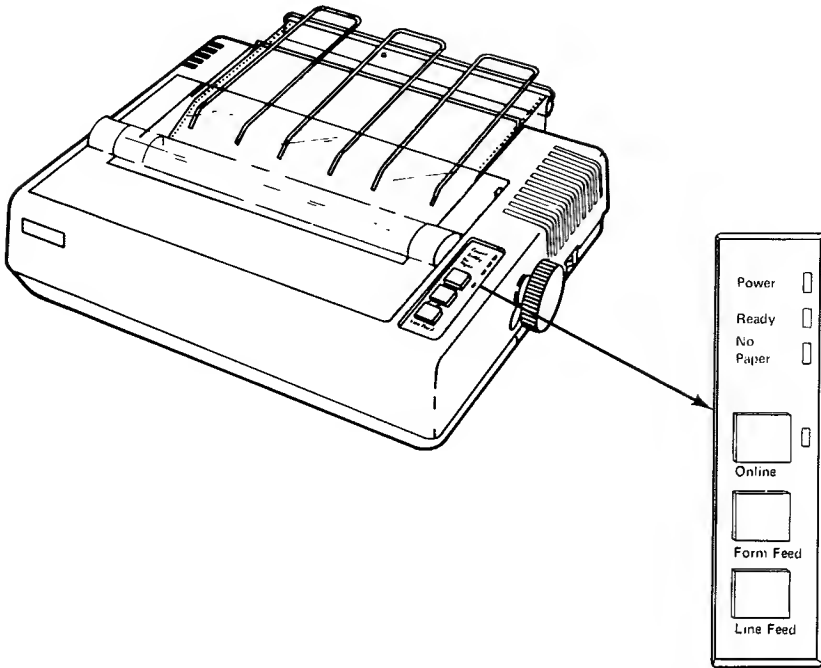

- 1. Online** button changes the Online and Offline modes. The printer is in the Online mode when powered on. (Online light is on.) Pressing the Online button once places the printer in the Offline mode. (Online light is off.) Pressing the button once again places the printer back in the Online mode.
- 2. Form Feed** button is pressed to advance the paper to the top of the next page. The printer must be in the Offline mode before the Form Feed button will work.
- 3. Line Feed** button is pressed to advance the forms to the next line on the page. When the Line Feed button is held down, the paper will continue feeding until the button is released. The printer must be in the Offline mode before the Line Feed button will work.

Ribbon Cartridge Installation

1. Set the printer Power switch to OFF.
2. Raise the printer access cover and lift it from the printer base as shown.

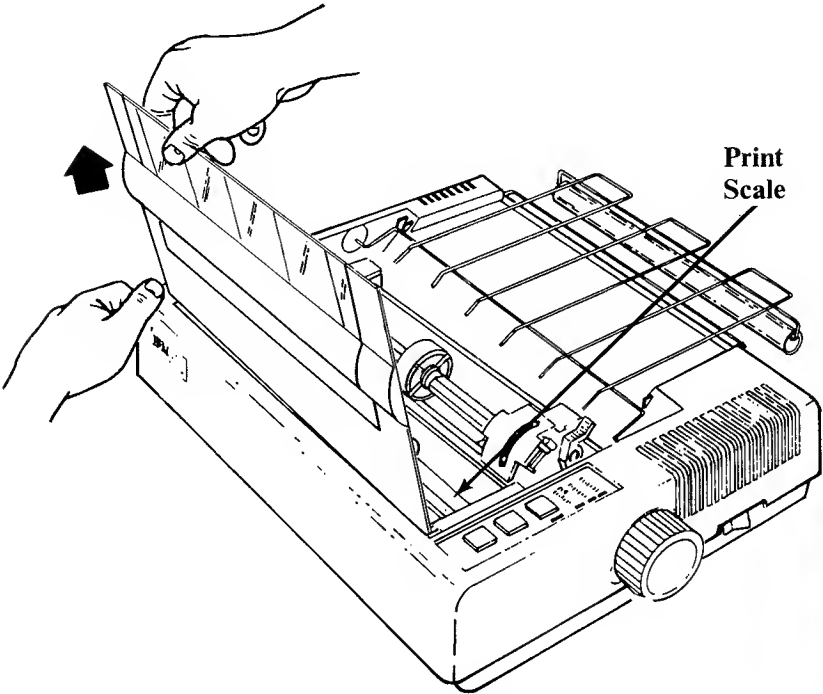

3. Check the print scale to be sure it is in the rear position.
4. Remove the ribbon cartridge from the packing material.

PRINTERS

- 5.** Grasp the fin in the center of the ribbon cartridge.

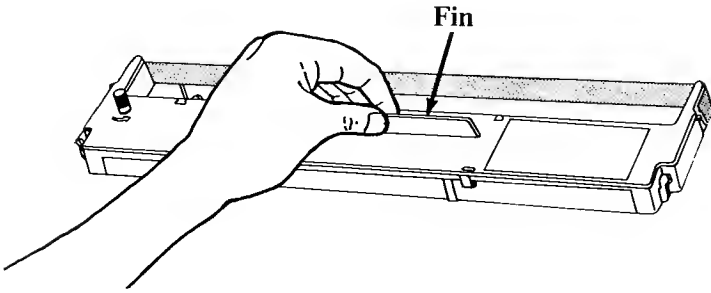

- 6.** Guide the two tabs on the left side of the ribbon cartridge into the two slots on the left side of the printer frame.

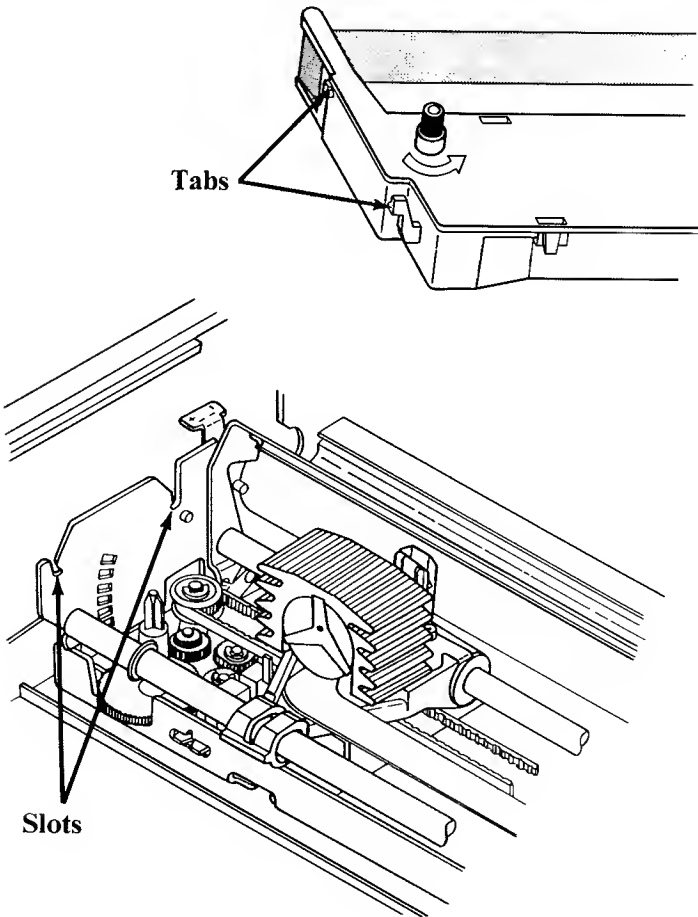

7. Guide the two tabs on the right side of the ribbon cartridge into the two slots on the right side of the printer frame. Press your ribbon cartridge firmly into place and turn the knob in the direction of the arrow to remove any slack in the ribbon.

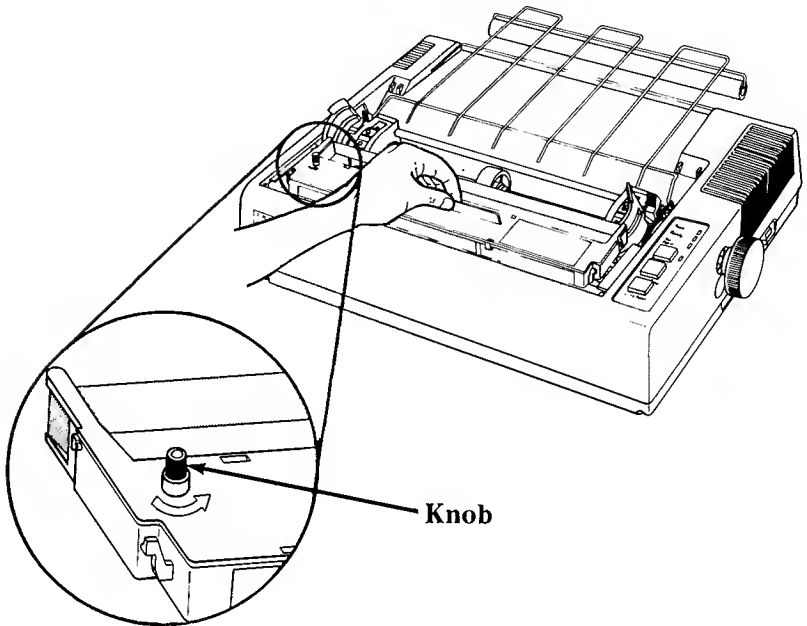

8. Using a pencil or your finger, guide the ribbon into the slot between the nose of the print head and the ribbon shield.

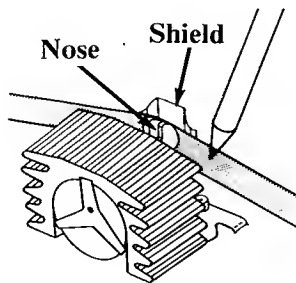

9. Carefully move the print head to be sure the ribbon is free to move between the nose of the print head and the ribbon shield.
10. Replace the printer cover by reversing the procedure in Step 2.

Forms Installation

1. Set the printer Power switch to OFF.
2. Raise the printer access cover and lift it from the printer base as shown.

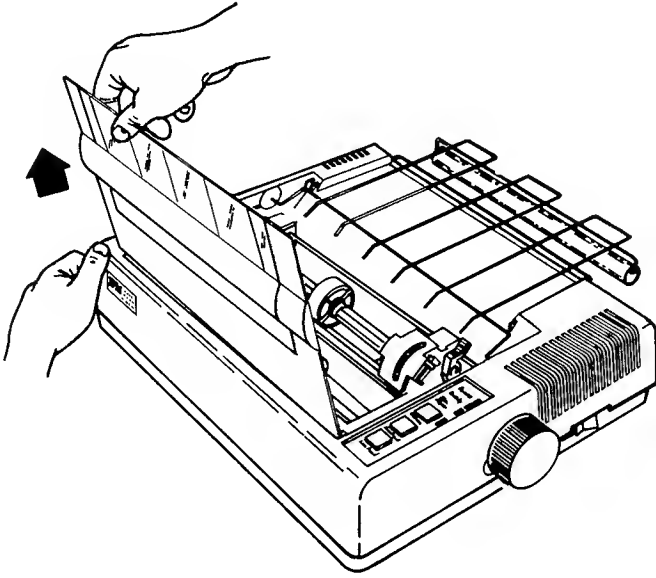

3. Position the forms behind and below the printer. If you have a printer stand, that's ideal. The floor will also work well. See the example below.

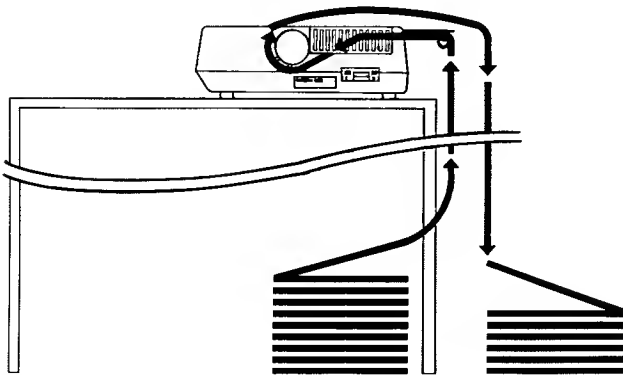

4. Move the print scale towards you, and center the forms guide roller.
5. Open the tractor covers.

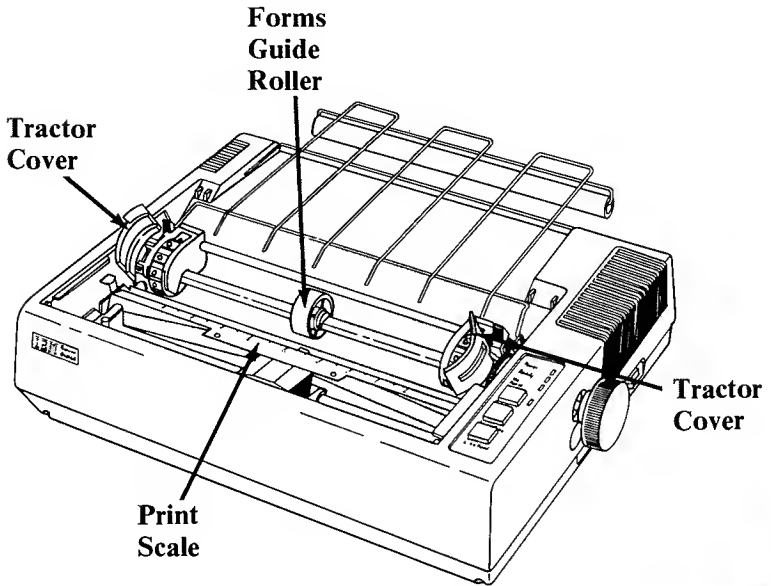

6. Insert the end of the forms into the opening between the forms rack and plastic roller.

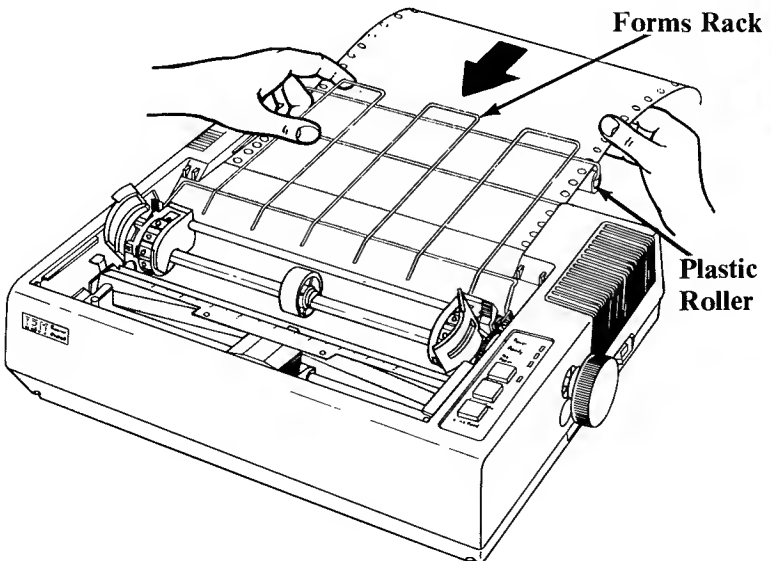

7. Tilt the forms rack up, as shown, when you guide the forms into the printer opening.

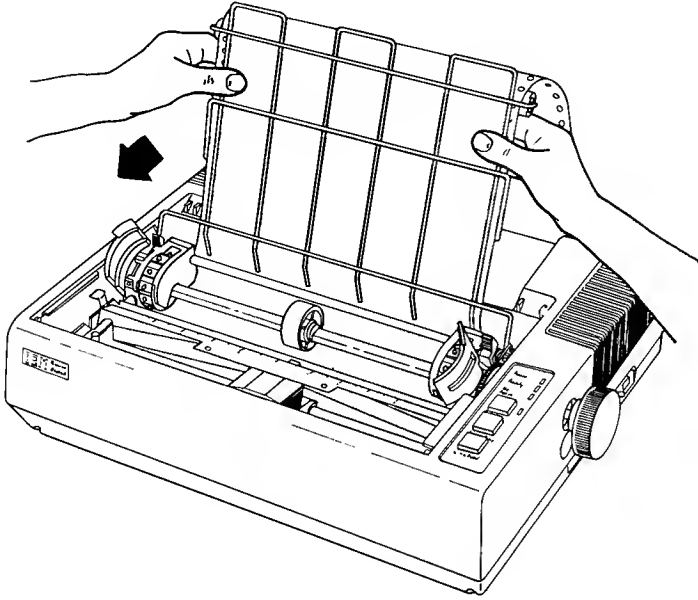

8. Push the forms into the opening until 3 or 4 inches appear in the front.

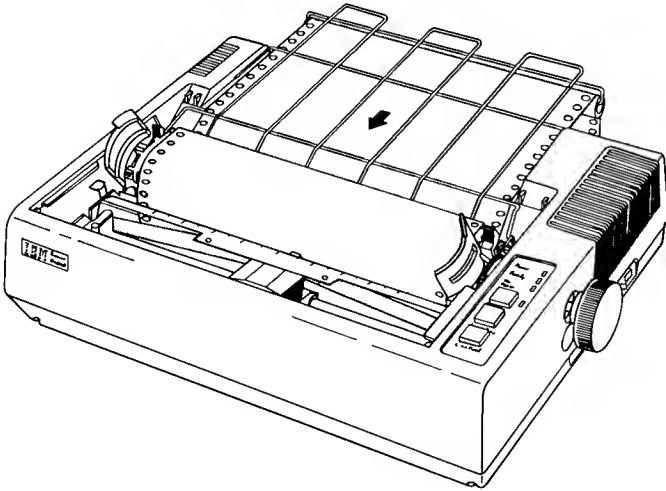

9. If the forms width is different from the distance between the tractors, unlock the tractors by tilting the tractor lock levers forward and slide the tractors over.

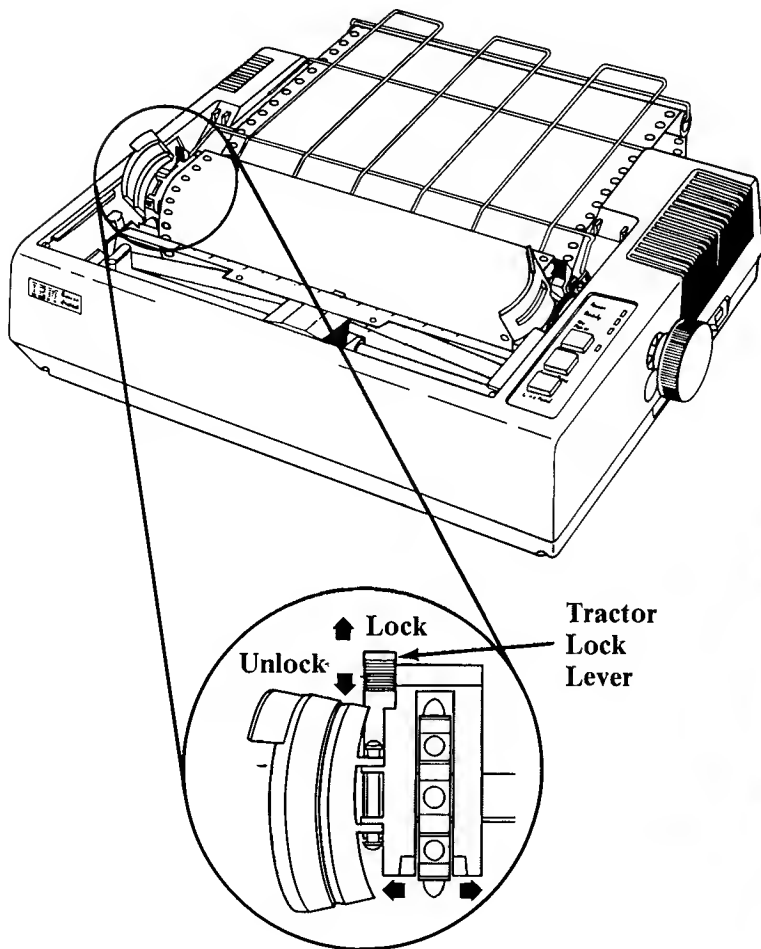

10. Position the forms holes on top of the tractor pins and close the tractor covers. Adjust the tractors so the forms are centered and to remove any buckle in the forms.
11. Lock the tractors in place by tilting the tractor lock levers to the rear.

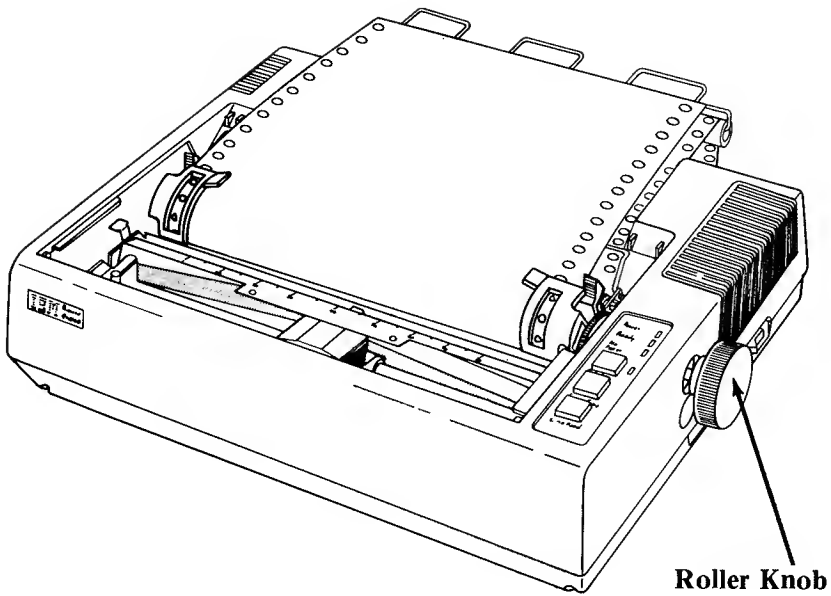

WARNING: Always roll the forms ahead. Rolling the forms backwards may damage your printer.

- 12.** Roll the forms up with the Roller knob. Look to see that the forms are feeding properly. (Be sure that the forms are centered under or behind the printer. Do not allow the forms to rub against anything, including the printer cable.)
- 13.** Move the print scale to the rear so that it is against the forms.
- 14.** Replace the access cover by reversing the instructions in Step 2.

Top of Page Setting

- 1.** Set the printer Power switch to OFF.
- 2.** Raise the printer cover.
- 3.** Using the roller knob, position the page perforation near the top of the print scale.
- 4.** Set the printer Power switch to ON.
- 5.** Lower the printer access cover.
- 6.** To change the Top of Page Setting, repeat the procedure in Steps 1-5.

Note: The position of the forms, when the printer is powered on, determines where the forms will feed to when the Form Feed command is given. Pressing the Form Feed button, when the printer is Offline, will also feed the forms to the next Top of Page. The length of the page can be changed using printer commands from the system unit. When the printer is powered off and powered on again, or receives printer reset from the system unit, the page length will be 11 inches.

Forms Thickness Control

The forms thickness lever is used to adjust the position of the print head to allow room for single- or multi-part forms. Move the lever towards the rear for single forms and forward for multi-part forms.

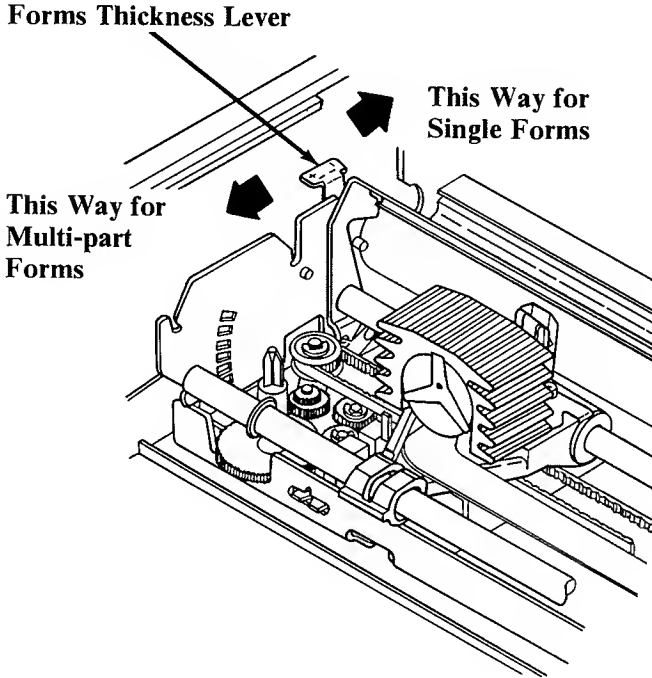

Left Margin Adjustment

1. Set the printer Power switch to OFF.
2. Decide where you would like to have your printer start and mark that position on the forms. (The mark must be between the left edge of the forms and not more than 1-3/4 inches from the left edge of the forms, including the perforated edge.)

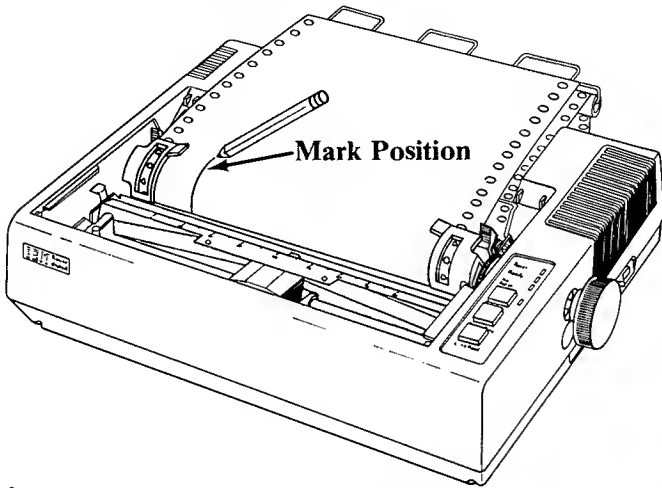

3. Unlock the tractors, right and left, by tilting the tractor lock levers forward.
4. Slide the tractor assemblies, with the forms, to align the mark on the forms with the number 1 position on the print scale.

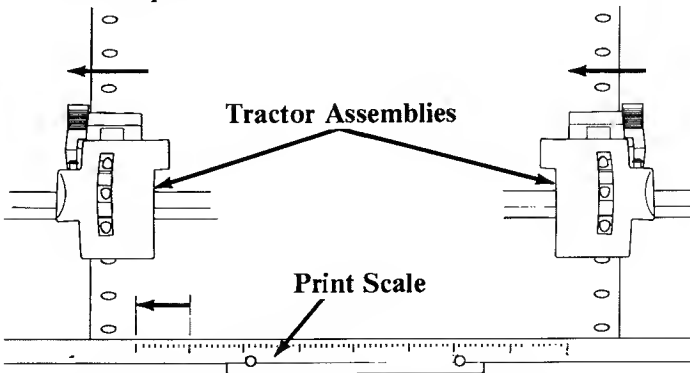

5. Lock both tractor assemblies in place by tilting both tractor lock levers back.

Printer Self-Test

To verify that your printer is operating correctly, you should run the printer test in the Problem Determination Procedures and the printer self-test.

1. Set the printer Power switch and the system unit Power switch to Off.
2. Disconnect the printer cable from the back of the printer.
3. Press and hold the Line Feed button down while you set the printer Power switch to ON.
4. After the test starts, you can release the Line Feed button.

Note: The printer self-test will run for about 10 minutes.

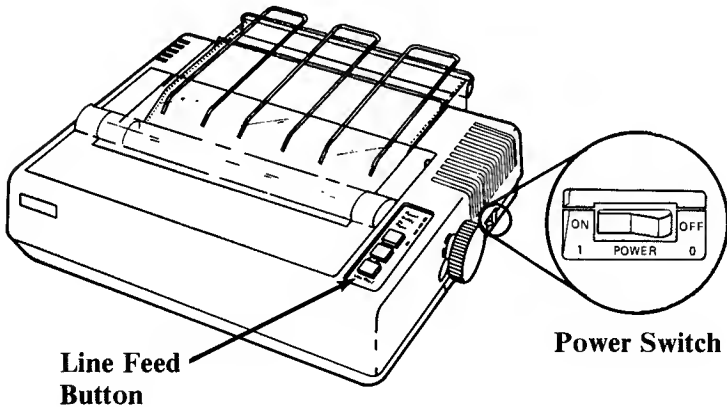

5. To stop the printer self-test before it is finished, set the printer Power switch to OFF.

6. Below are partial examples of the printout for 80 CPS Printers.

IBM 80 CPS Matrix Printer

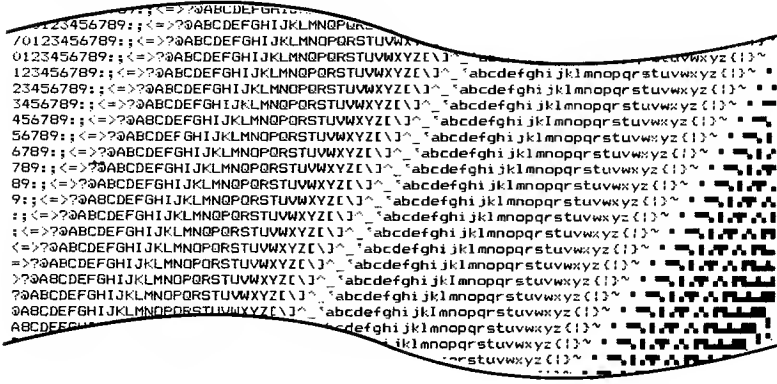

IBM 80 CPS Graphics Printer

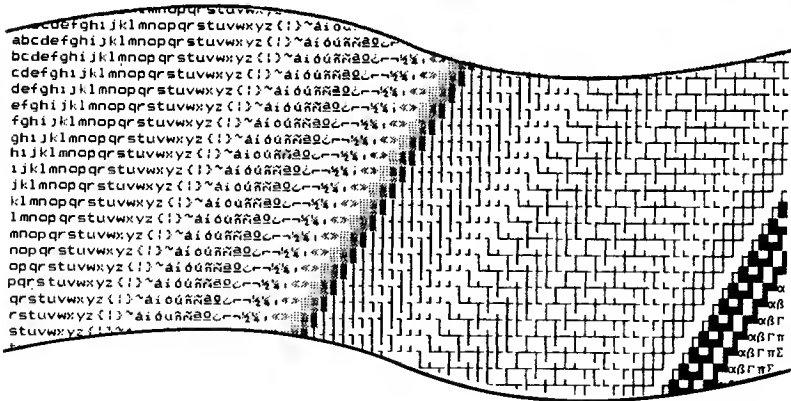

PRINTERS

IBM 80 CPS Matrix/Graphics Printer Modes

Below are the allowed combinations of print modes that can be selected.

The IBM 80 CPS Graphics Printer can select any of the combinations listed below and can change print modes at any place within a line.

The IBM 80 CPS Matrix Printer cannot select Subscript, Superscript or Underline print modes. Double Width print affects the entire line.

Note: Modes can be selected and combined if they are in the same vertical column in the following figure.

Print Modes

Normal	X	X	X															
Compressed					X	X	X											
Emphasized												X	X	X				
Double Strike	X				X							X						
Subscript		X				X							X					
Superscript			X				X											X
Double Width	X	X	X		X	X	X					X	X	X				
Underline	X	X	X		X	X	X					X	X	X				

Printer Control Codes for IBM 80 CPS Matrix Printer

To tell your printer how and what you would like to print you must first send special characters from the system unit to your printer. These special characters are called printer control codes.

Below are two examples using printer control codes with IBM Personal Computer Cassette BASIC.

Example 1

The first example gives a printer instruction to print in the Double Width print mode.

1. Set the printer and system unit Power switches to On. Do not load a diskette. The system will come up in IBM Personal Computer Cassette BASIC.
2. Type: `LPRINT CHR$(14); Personal Computer`
3. Press .
4. Your printer will print:

Personal Computer

Example 2

The second example shows the use of an ASCII Escape character with another ASCII character to instruct the printer to print in the Emphasized print mode.

1. Type:
LPRINT CHR\$(27);CHR\$(69);"IBM Personal Computer"
2. Press 
3. Your printer will print:
IBM Personal Computer

On the following pages you will find codes for printer controls, characters and graphics. Some knowledge of BASIC programming is necessary for an understanding of these codes. The printer control codes are listed in ASCII decimal, numerical order (e.g., NULL is zero to ESC Z which is ASCII decimal 90). Examples given are written in the BASIC language. The "Format" description is given when more information is needed for programming considerations.

The ASCII decimal values for the printer control codes and characters can be found in the Printer Control Code and Character Charts located in the back of this section.

**Printer
Code**

Printer Function

NUL	<p>Null</p> <p>Used with ESC B and ESC D as a list terminator. NUL is also used with other printer control codes to select options (e.g., ESC S).</p> <p>Example:</p> <pre>LPRINT CHR\$(0);</pre>
BEL	<p>Bell</p> <p>Sounds the printer buzzer for 1 second.</p> <p>Example:</p> <pre>LPRINT CHR\$(7);</pre>
HT	<p>Horizontal Tab</p> <p>Tabs to the next horizontal tab stop. Tab stops are set with ESC D. No tab stops are set when the printer is powered on. (Graphics Printer sets a tab stop every 8 columns when powered on.)</p> <p>Example:</p> <pre>LPRINT CHR\$(9);</pre>
LF	<p>Line Feed</p> <p>Spaces the paper up one line. Line spacing is 1/16-inch unless reset by ESC A, ESC 0, ESC 1, ESC 2, or ESC 3.</p> <p>Example:</p> <pre>LPRINT CHR\$(10);</pre>
VT	<p>Vertical Tab</p> <p>Spaces the paper to the next vertical tab position. (Graphics Printer does not allow vertical tabs to be set; therefore, the VT code is treated as LF.)</p> <p>Example:</p> <pre>LPRINT CHR\$(11);</pre>
FF	<p>Form Feed</p> <p>Advances the paper to the top of the next page.</p> <p>Note: The location of the paper, when the printer is powered on, determines the top of the page. The next top of page is 11 inches from that position. ESC C can be used to change the page length.</p> <p>Example:</p> <pre>LPRINT CHR\$(12);</pre>

Printer Code	Printer Function
CR	<p>Carriage Return</p> <p>Ends the line the printer is on and prints the data remaining in the printer buffer. (No Line Feed operation takes place.)</p> <p>Note: IBM Personal Computer BASIC adds a Line Feed unless 128 is added [i.e., CHR\$(141)].</p> <p>Example:</p> <pre>LPRINT CHR\$(13);</pre>
SO	<p>Shift Out (Double Width)</p> <p>Changes the printer to the Double Width print mode.</p> <p>Note: A Carriage Return, Line Feed or DC4 cancels Double Width print mode.</p> <p>Example:</p> <pre>LPRINT CHR\$(14);</pre>
SI	<p>Shift In (Compressed)</p> <p>Changes the printer to the Compressed Character print mode.</p> <p>Example:</p> <pre>LPRINT CHR\$(15);</pre>
DC2	<p>Device Control 2 (Compressed Off)</p> <p>Stops printing in the Compressed Character print mode.</p> <p>Example:</p> <pre>LPRINT CHR\$(18);</pre>
DC4	<p>Device Control 4 (Double Width Off)</p> <p>Stops printing in the Double Width print mode.</p> <p>Example:</p> <pre>LPRINT CHR\$(20);</pre>
CAN	<p>Cancel</p> <p>Clears the printer buffer. Control codes, except SO, remain in effect.</p> <p>Example:</p> <pre>LPRINT CHR\$(24);</pre>

Printer**Code Printer Function**

- ESC** **Escape**
Lets the printer know that the next data sent is a printer command. (See the following list of commands.)
Example:
LPRINT CHR\$(27);
- ESC -** **Escape Minus (Underline)**
Format: ESC -;n;
(Graphics Printer only)
ESC - followed by a 1, prints all of the following data with an underline.
ESC - followed by a 0 (zero), cancels the Underline print mode.
Example:
LPRINT CHR\$(27);CHR\$(45);CHR\$(1);
- ESC 0** **Escape Zero (1/8-inch Line Feeding)**
Changes paper feeding to 1/8 inch.
Example:
LPRINT CHR\$(27);CHR\$(48);
- ESC 1** **Escape 1 (7/72-inch Line Feeding)**
Changes paper feed to 7/72 inch.
Example:
LPRINT CHR\$(27);CHR\$(49);
- ESC 2** **Escape Two (Starts Variable Line Feeding)**
ESC 2 is an execution command for ESC A. If no ESC A command has been given, line feeding returns to 1/6-inch.
Example:
LPRINT CHR\$(27);CHR\$(50);
- ESC 3** **Escape Three (Variable Line Feeding)**
Format: ESC 3;n;
(Graphics Printer only)
Changes the paper feeding to n/216-inch. The example below sets the paper feeding to 54/216 (1/4) inch. The value of n must be between 1 and 255.
Example:
LPRINT CHR\$(27);CHR\$(51);CHR\$(54);

Printer Code	Printer Function
ESC 6	Escape Six (Select Character Set 2) (Graphics Printer only) Selects character set 2. (See Printer Character Set 2.) Example: LPRINT CHR\$(27);CHR\$(54);
ESC 7	Escape Seven (Select Character Set 1) (Graphics Printer only) Selects character set 1. (See Printer Character Set 1.) Character set 1 is selected when the printer is powered on or reset. Example: LPRINT CHR\$(27);CHR\$(55);
ESC 8	Escape Eight (Ignore Paper End) Allows the printer to print to the end of the paper. The printer ignores the Paper End Switch. Example: LPRINT CHR\$(27);CHR\$(56);
ESC 9	Escape Nine (Cancel Ignore Paper End) Cancels the Ignore Paper End command. ESC 9 is selected when the printer is powered on or reset. Example: LPRINT CHR\$(27);CHR\$(57);
ESC <	Escape Less Than (Home Head) (Graphics Printer only) The print head will return to the left margin to print the line following ESC <. This will occur for one line only. Example: LPRINT CHR\$(27);CHR\$(60);

**Printer
Code**

Printer Function

ESC A

Escape A (Sets the Variable Line Feeding)

Format: ESC A;n;

Escape A sets the line feed feeding to $n/72$ -inch. The example below tells the printer to set line feeding to $24/72$ -inch. ESC 2 must be sent to the printer before the line feeding will change. For example, ESC A;24 (text) ESC 2 (text). The text following ESC A;24 will space at previously set line-feed increments. The text following ESC 2 will be printed with new line feed increments of $24/72$ -inch. Any increment between $1/72$ and $85/72$ may be used.

Example:

```
LPRINT CHR$(27);CHR$(65);CHR$(24);CHR$(27);  
CHR$(50);
```

ESC B

Escape B (Set Vertical Tabs)

Format: ESC B;n₁;n₂;...n_k;NUL;

(Graphics Printer ignores ESC B)

Sets vertical tab stop positions. Up to 64 vertical tab stop positions are recognized by the printer. The n's, in the format above indicate tab stop positions. Tab stop numbers must be received in ascending numerical order. The tab stop numbers will not become valid until the NUL code is input. Once vertical tab stops are established, they will be valid until new tab stops are specified. (If the printer is reset or powered off, set tab stops are cleared.) If no tab stop is set, the Vertical Tab command behaves as a Line Feed command. ESC B followed only by NUL will cancel tab stops. The form length must be set by the ESC C command prior to setting tabs.

Example:

```
LPRINT CHR$(27);CHR$(66);CHR$(10);CHR$(20);  
CHR$(40);CHR$(0);
```

Printer Code Printer Function

ESC C Escape C (Set Lines Per Page)
Format: ESC C;n;
Sets the page length. The ESC C command must have a value following it to specify the length of page desired. (Maximum form length for the printer is 127 lines.) The example below sets the page length to 55 lines. The printer defaults to 66 lines per page when powered on or reset.
Example:
LPRINT CHR\$(27);CHR\$(67);CHR\$(55);

Escape C (Set Inches Per Page)
Format: ESC C;n;m;
(Graphics Printer only)
Escape C sets the length of the page in inches. This command requires a value of 0 (zero) for n, and a value between 1 and 22 for m.
Example:
LPRINT CHR\$(27);CHR\$(67);CHR\$(0);CHR\$(12);

ESC D Escape D (Set Horizontal Tab Stops)
Format: ESC D;n₁;n₂;...n_k;NUL;
Sets the horizontal tab stop positions. The example below shows the horizontal tab positions set at printer column positions of 10, 20 and 40. They are followed by CHR\$(0), the NUL code. They must also be in ascending numerical order as shown. Tab stops can be set between 1 and 80. When the printer is in the Compressed print mode, tab stops can be set up to 132.
The maximum number of tabs that can be set is 112. Graphics Printer can have a maximum of 28 tab stops. The HT [CHR\$(9)] is used to execute a tab operation.
Example:
LPRINT CHR\$(27);CHR\$(68);CHR\$(10)CHR\$(20)CHR\$(40);CHR\$(0);

**Printer
Code**

Printer Function

- ESC E Escape E (Emphasized)
Changes the printer to the Emphasized print mode. The speed of the printer is reduced to half speed during the Emphasized print mode.
Example:
LPRINT CHR\$(27);CHR\$(69);
- ESC F Escape F (Emphasized Off)
Stops printing in the Emphasized print mode.
Example:
LPRINT CHR\$(27);CHR\$(70);
- ESC G Escape G (Double Strike)
Changes the printer to the Double Strike print mode. The paper is spaced 1/216 of an inch before the second pass of the print head.
Example:
LPRINT CHR\$(27);CHR\$(71);
- ESC H Escape H (Double Strike Off)
Stops printing in the Double Strike mode.
Example:
LPRINT CHR\$(27);CHR\$(72);
- ESC J Escape J (Set Variable Line Feeding)
Format: ESC J;n;
(Graphics Printer only)
When ESC J is sent to the printer, the paper will feed in increments of n/216 of an inch. The value of "n" must be between 1 and 255. The example below gives a line feed of 50/216-inch. ESC J is canceled after the line feed takes place.
Example:
LPRINT CHR\$(27);CHR\$(74);CHR\$(50);

PRINTERS

Printer Code

Printer Function

ESC K Escape K (480 Bit Image Graphics Mode)

Format: ESC K; n_1 ; n_2 ; v_1 ; v_2 ;... v_k ;

(Graphics Printer only)

Changes from the Text mode to the Bit Image Graphics mode. n_1 and n_2 are numbers, each consisting of 1 byte, which specify the number of bit image data bytes to be transferred. v_1 through v_k are the bytes of bit image data. The number of bit image data bytes (k) is equal to $n_1 + 256n_2$ and cannot exceed 480 bytes. At each horizontal position each byte can print up to 8 vertical dots. Bit image data may be mixed with Text data on the same line.

Note: Assign values to n_1 and n_2 as follows: n_1 represents values from 0-255. n_2 represents values from $0-1 \times 256$.

MSB is most significant bit and LSB is least significant bit.

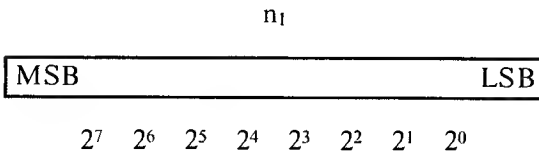
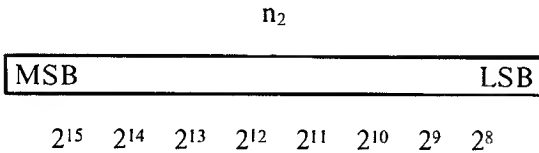

Data sent to the printer.

Text (20 characters)	ESC	K	n=360	Bit-image data	Next data
----------------------	-----	---	-------	----------------	-----------

20 characters in text mode correspond to 120 bit-image positions ($20 \times 6 = 120$). The printable portion left in Bit-Image mode is 360 dot positions ($480 - 120 = 360$).

Data sent to the printer.

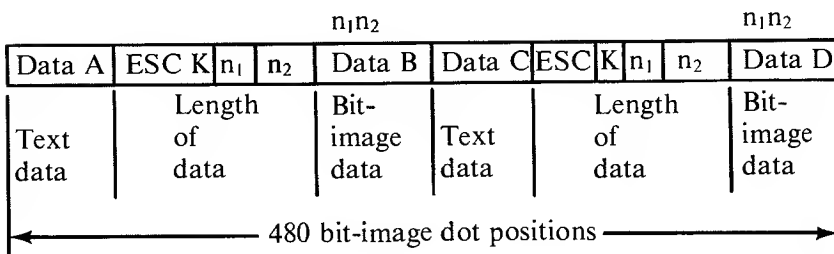

Example:

TYPE B:GRAPH.TXT

```

1 'OPEN PRINTER IN RANDOM MODE WITH LENGTH OF
  255
2 OPEN "LPT1:" AS #1
3 WIDTH "LPT1:",255
4 PRINT #1,CHR$(13);CHR$(10);
5 SLASH$=CHR$(1)+(CHR$(02)+CHR$(04)+CHR$(08)
6 SLASH$=SLASH$+CHR$(16)+CHR$(32)+
  CHR$(64)+CHR$(128)+CHR$(0)
7 GAP$=CHR$(0)+CHR$(0)+CHR$(0)
8 NDOTS=480
9 'ESC K N1 N2
10 PRINT #1,CHR$(27);"K";CHR$(NDOTS MOD 256);
  CHR$(FIX(NDOTS/256));
11 'SEND NDOTS NUMBER OF BIT IMAGE BYTES
12 FOR I=1 TO NDOTS/12 'NUMBER OF SLASHES TO
  PRINT USING GRAPHICS
13 PRINT #1,SLASH$;GAP$;
14 NEXT I
15 CLOSE
16 END
  
```

This example will give you a row of slashes printed in the 480 Bit-Image mode.

**Printer
Code**

Printer Function

- ESC L Escape L (960 Bit Image Graphics Mode)
Format: ESC L; n_1 ; n_2 ; v_1 ; v_2 ;... v_k ;
(Graphics Printer only)
Changes from the Text mode to the Bit Image Graphics mode. The input is similar to ESC K. The 960 Bit Image mode prints at half the speed of the 480 Bit Image Graphics mode, but can produce a denser graphic image. The number of bytes of Bit Image Data (k) is $n_1 + 256n_2$ but cannot exceed 960. n_1 is in the range of 0 to 255.
- ESC N Escape N (Set Skip Perforation)
Format: ESC N; n ;
(Graphics Printer only)
Sets the Skip Perforation function. The number following ESC N sets the value for the number of lines of Skip Perforation. The example shows a 12-line skip perforation. This will print 54 lines and feed the paper 12 lines. The value of n must be between 1 and 127. ESC N is reset anytime the page length (ESC C) is changed.
Example:
LPRINT CHR\$(27);CHR\$(78);CHR\$(12);
- ESC O Escape O (Cancel Skip Perforation)
(Graphics Printer only)
Cancels the Skip Perforation function.
Example:
LPRINT CHR\$(27);CHR\$(79);
- ESC S Escape S (Subscript/Superscript)
Format: ESC S; n ;
(Graphics Printer only)
Changes the printer to the Subscript print mode when ESC S is followed by a 1, as in the example below. When ESC S is followed by a 0 (zero), the printer will print in the Superscript print mode.
Example:
LPRINT CHR\$(27);CHR\$(83);CHR\$(1);

Printer Code	Printer Function
ESC T	<p>Escape T (Subscript/Superscript Off) (Graphics Printer only) The printer stops printing in the Subscript or Superscript print mode. Example: LPRINT CHR\$(27);CHR\$(84);</p>
ESC U	<p>Escape U (Unidirectional Printing) Format: ESC U;n; (Graphics Printer only) The printer will print from left to right following the input of ESC U;1. When ESC U is followed by a 0 (zero), the left to right printing operation is canceled. The Unidirectional print mode (ESC U) ensures a more accurate printing start position for better print quality. Example: LPRINT CHR\$(27);CHR\$(85);CHR\$(1);</p>
ESC W	<p>Escape W (Double Width) Format: ESC W;n; (Graphics Printer only) Changes the printer to the Double Width mode when ESC W is followed by a 1. This mode is not canceled by a line feed operation and must be canceled with ESC W followed by a 0 (zero). Example: LPRINT CHR\$(27);CHR\$(87);CHR\$(1);</p>
ESC Y	<p>Escape Y (960 Bit Image Graphics Mode Normal Speed) Format: ESC Y n₁;n₂;v₁;v₂;...v_k; (Graphics Printer only) Changes from the Text mode to the 960 Bit Image Graphics mode. The printer prints at normal speed during this operation and cannot print dots on consecutive dot positions. The input of data is similar to ESC L.</p>
ESC Z	<p>Escape Z (1920 Bit Image Graphics Mode) Format: ESC Z;n₁;n₂;v₁;v₂;...v_k; (Graphics Printer only) Changes from the Text mode to the 1920 Bit Image Graphics mode. The input is similar to the other Bit Image Graphics modes. ESC Z can print only every third dot position.</p>

Matrix Printer Control and Character Chart with ASCII Decimal Value

0	1	2	3	4	5	6	7	8	9
NUL							BEL		HT
10	11	12	13	14	15	16	17	18	19
LF	VT	FF	CR	SO	SI		DC1	DC2	DC3
20	21	22	23	24	25	26	27	28	29
DC4				CAN			ESC		
30	31	32	33	34	35	36	37	38	39
		SP	!	"	#	\$	%	&	'
40	41	42	43	44	45	46	47	48	49
()	*	+	,	-	.	/	0	1
50	51	52	53	54	55	56	57	58	59
2	3	4	5	6	7	8	9	:	;
60	61	62	63	64	65	66	67	68	69
<	=	>	?	⌚	A	B	C	D	E
70	71	72	73	74	75	76	77	78	79
F	G	H	I	J	K	L	M	N	O
80	81	82	83	84	85	86	87	88	89
P	Q	R	S	T	U	V	W	X	Y
90	91	92	93	94	95	96	97	98	99
Z	[\]	^	_	`	a	b	c
100	101	102	103	104	105	106	107	108	109
d	e	f	g	h	i	j	k	l	m
110	111	112	113	114	115	116	117	118	119
n	o	p	q	r	s	t	u	v	w
120	121	122	123	124	125	126	127	128	129
x	y	z	{		}	~	DEL	NUL	

Matrix Printer Control and Character Chart with ASCII Decimal Value (continued)

130	131	132	133	134	135	136	137	138	139
					BEL		HT	LF	
140	141	142	143	144	145	146	147	148	149
FF	CR	SO	SI		DC1	DC2	DC3	DC4	
150	151	152	153	154	155	156	157	158	159
		CAN			ESC				
160	161	162	163	164	165	166	167	168	169
170	171	172	173	174	175	176	177	178	179
180	181	182	183	184	185	186	187	188	189
190	191	192	193	194	195	196	197	198	199
200	201	202	203	204	205	206	207	208	209
210	211	212	213	214	215	216	217	218	219
220	221	222	223						

PRINTERS

Graphics Printer Control and Character Chart with ASCII Decimal Value Set 1

0	1	2	3	4	5	6	7	8	9
NUL							BEL		HT
10	11	12	13	14	15	16	17	18	19
LF		FF	CR	SO	SI			DC2	
20	21	22	23	24	25	26	27	28	29
DC4				CAN			ESC		
30	31	32	33	34	35	36	37	38	39
		SP	!	"	#	\$	%	&	'
40	41	42	43	44	45	46	47	48	49
()	*	+	,	-	.	/	0	1
50	51	52	53	54	55	56	57	58	59
2	3	4	5	6	7	8	9	:	;
60	61	62	63	64	65	66	67	68	69
<	=	>	?	Ⓞ	A	B	C	D	E
70	71	72	73	74	75	76	77	78	79
F	G	H	I	J	K	L	M	N	O
80	81	82	83	84	85	86	87	88	89
P	Q	R	S	T	U	V	W	X	Y
90	91	92	93	94	95	96	97	98	99
Z	[\]	^	_	`	a	b	c
100	101	102	103	104	105	106	107	108	109
d	e	f	g	h	i	j	k	l	m
110	111	112	113	114	115	116	117	118	119
n	o	p	q	r	s	t	u	v	w
120	121	122	123	124	125	126	127	128	129
x	y	z	{		}	~		NUL	

Graphics Printer Control and Character Chart with ASCII Decimal Value Set 1 (continued)

130	131	132	133	134	135	136	137	138	139
					BEL		HT	LF	
140	141	142	143	144	145	146	147	148	149
FF	CR	SO	SI			DC2		DC4	
150	151	152	153	154	155	156	157	158	159
		CAN			ESC				
160	161	162	163	164	165	166	167	168	169
á	í	ó	ú	ñ	Ñ	<u>a</u>	<u>o</u>	¿	┐
170	171	172	173	174	175	176	177	178	179
┐	½	¼	¡	«	»	▒	▒	▒	▒
180	181	182	183	184	185	186	187	188	189
┌	┌	┌	┌	┌	┌	┌	┌	┌	┌
190	191	192	193	194	195	196	197	198	199
└	└	└	└	└	└	└	└	└	└
200	201	202	203	204	205	206	207	208	209
┐	┐	┐	┐	┐	┐	┐	┐	┐	┐
210	211	212	213	214	215	216	217	218	219
┌	┌	┌	┌	┌	┌	┌	┌	┌	┌
220	221	222	223	224	225	226	227	228	229
█	█	█	█	α	β	Γ	Π	Σ	σ
230	231	232	233	234	235	236	237	238	239
μ	τ	ϕ	θ	Ω	δ	∞	∅	ε	∩
240	241	242	243	244	245	246	247	248	249
≡	±	≥	≤	∫	∫	÷	≈	◦	■
250	251	252	253	254	255				
-	√	∩	2	■	SP				

PRINTERS

Graphics Printer Control and Character Chart with ASCII Decimal Value Set 2

0	1	2	3	4	5	6	7	8	9
NUL			♥	♦	♣	♠	BEI		HT
10	11	12	13	14	15	16	17	18	19
LF		FF	CR	SO	SI			DC2	
20	21	22	23	24	25	26	27	28	29
DC4	§			CAN			ESC		
30	31	32	33	34	35	36	37	38	39
		SP	!	”	#	\$	%	&	'
40	41	42	43	44	45	46	47	48	49
()	*	+	,	-	.	/	0	1
50	51	52	53	54	55	56	57	58	59
2	3	4	5	6	7	8	9	:	;
60	61	62	63	64	65	66	67	68	69
<	=	>	?	Ⓞ	A	B	C	D	E
70	71	72	73	74	75	76	77	78	79
F	G	H	I	J	K	L	M	N	O
80	81	82	83	84	85	86	87	88	89
P	Q	R	S	T	U	V	W	X	Y
90	91	92	93	94	95	96	97	98	99
Z	[\]	^	_	`	a	b	c
100	101	102	103	104	105	106	107	108	109
d	e	f	g	h	i	j	k	l	m
110	111	112	113	114	115	116	117	118	119
n	o	p	q	r	s	t	u	v	w
120	121	122	123	124	125	126	127	128	129
x	y	z	{		}	~		ç	ü

Graphics Printer Control and Character Chart with ASCII Decimal Value Set 2 (continued)

130	131	132	133	134	135	136	137	138	139
é	â	ä	à	å	ç	ê	ë	è	ï
140	141	142	143	144	145	146	147	148	149
î	ì	Ä	Å	É	æ	Æ	ô	ö	ò
150	151	152	153	154	155	156	157	158	159
û	ù	ÿ	ö	ü	ç	£	¥	₤	₣
160	161	162	163	164	165	166	167	168	169
á	í	ó	ú	ñ	Ñ	à	ó	¿	┘
170	171	172	173	174	175	176	177	178	179
┘	½	¼	¡	«	»	▒	▓	▔	▩
180	181	182	183	184	185	186	187	188	189
┐	┌	└	┘	┐	┌	└	┘	┐	┌
190	191	192	193	194	195	196	197	198	199
┘	┌	└	┘	┐	┌	└	┘	┐	┌
200	201	202	203	204	205	206	207	208	209
┘	┌	└	┘	┐	┌	└	┘	┐	┌
210	211	212	213	214	215	216	217	218	219
┐	┌	└	┘	┐	┌	└	┘	┐	┌
220	221	222	223	224	225	226	227	228	229
▒	▓	▔	▩	α	β	Γ	Π	Σ	σ
230	231	232	233	234	235	236	237	238	239
μ	τ	ϕ	θ	Ω	δ	∞	∅	€	∩
240	241	242	243	244	245	246	247	248	249
≡	±	≥	≤	∫	∫	÷	≈	°	■
250	251	252	253	254	255				
-	√	∩	2	■	SP				

PRINTERS

Notes:

Using DOS

Contents

Introduction	3-3
Our Notation	3-4
Starting DOS	3-5
If Your Computer Is Off	3-6
If Your Computer Is On	3-7
Telling DOS the Date	3-8
Telling DOS the Time	3-10
The DOS Prompt	3-11
Changing the Default Drive	3-13
Controlling DOS	3-14
Characters That Look Alike - “O’s” and “0’s” (zero), “I’s” and “L’s”	3-14
The Spacebar	3-15
The Shift and Caps Lock Keys	3-16
To Enter a Command	3-17
To Stop a Command	3-17
To Correct a Typing Mistake	3-18
To Stop the Screen Long Enough to Read It	3-19
To Print What Is On the Screen	3-19
To Print Whatever You Type	3-20
To Start DOS Again	3-20
About Diskettes	3-21
Tracks, Bytes, and Sectors	3-22
Careful Does It	3-24
Write-Protect Notch	3-25
An Important Exercise: Backing Up Your DOS Diskette	3-26
Before You Begin	3-26
If You Have One Drive	3-27
If You Have Two Drives	3-31
What’s on the DOS Diskette?	3-34
Files and Filenames	3-35
Global Filename Characters	3-39
An Exercise: Listing the DOS Diskette Files	3-42
DOS Diskette Files	3-44

DOS

Things You Can Do with DOS	3-45
Summary of Commands	3-45
FORMAT - Getting a Diskette Ready to Be Used	3-48
Before You Begin	3-49
If You Want DOS on Your Diskette	3-49
If You Do Not Want DOS on Your Diskette	3-51
Formatting Several Diskettes	3-51
DIR - Finding Out What Is on a Diskette	3-53
Before You Begin	3-53
To List All the Files	3-54
To List One File	3-55
DISKCOPY - Backing Up a Diskette	3-57
Before You Begin	3-57
Protecting Your Original Diskette	3-58
Backing Up with One Drive	3-59
Backing Up with Two Drives	3-61
COPY - Backing Up One File	3-64
Before You Begin	3-66
Copying a File to the Same Diskette	3-66
Copying a File to Another Diskette Using One Drive	3-67
Copying a File to Another Diskette Using Two Drives	3-71
TYPE - Displaying What Is in a File	3-73
Before You Begin	3-73
Here's How You Do It	3-73
RENAME - Changing a File's Name	3-75
Before You Begin	3-75
ERASE - Removing a File from a Diskette	3-78
Before You Begin	3-78
Global Filename Characters	3-80
MODE - Shifting the Display on the Screen	3-81
Before You Begin	3-81
Shift Right	3-81
Helps and Hints	3-83
Summary	3-85

Introduction

DOS stands for Disk Operating System. People are about evenly divided between saying d - o - s, or as one word, doss (to rhyme with hoss).

DOS is a collection of programs for your IBM Personal Computer, and is supplied to you on the DOS diskette. These programs process commands to let you manage information. They also help you manage the hardware resources (for example, the diskette drives and screen) of your computing system. DOS also does some things inside the machine, but because it does them for you, we won't describe them in this chapter.

This chapter tells you about starting DOS, about the diskettes, and about making a copy of the DOS diskette. Then we will take you through examples of the DOS commands you will use most often. After you've learned how to use these commands, you will probably want to refer to the *IBM Personal Computer Disk Operating System* book for more information on these and other commands, and on other DOS programs.

It is important that you make a copy of your DOS diskette. In fact, we suggest you do it several times. See "An Important Exercise," on page 3-27, for instructions.

Note: DOS 2.0 is required for the operation of a fixed disk drive. Refer to the DOS 2.0 manual if you have a fixed disk drive installed in your expansion unit.

Our Notation

DOS will let you type with either lowercase or uppercase letters (or a combination of both).

In this chapter, items that you type should be in lowercase letters because you will probably find it easier to type this way. For example,

```
dir a:*.*
```

shows what you should type.

We will show the names of commands, programs, and files in uppercase letters - like 80PRICES.AVG - both to make it easier for you to read and because that's how these names will be shown to you on the screen.

Starting DOS

You will usually want to start, or load, DOS whenever you start your computer. For example, you must have DOS loaded before you can start Disk BASIC or Advanced BASIC programs.

Starting or loading DOS means that a copy of the DOS programs are read from the DOS diskette and placed in the computer's memory. Once the computer finishes its self-checks, you will hear the diskette drive whirring and clicking while the DOS programs are being read and transferred to memory.

DOS lets you know it is ready by asking for the current date and time. After that, you type a command - that is, you tell DOS what you want it to do.

Let's look at how you start DOS, step-by-step.

There are two ways to start DOS, depending on whether your computer is off or on.

If Your Computer Is Off

1. Insert the DOS diskette into drive A and close the diskette drive door.

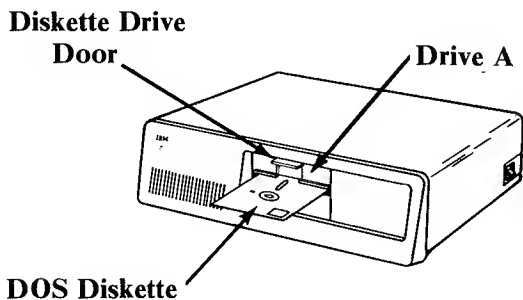

2. Turn on the printer, if you have one, a video display or TV, and then the computer.
3. There will be a pause (from 3 to 45 seconds) while the system checks itself out. Then you will hear the diskette drive clicking while DOS is being read and transferred.

If Your Computer Is On

1. Insert the DOS diskette in drive A and close the drive door.

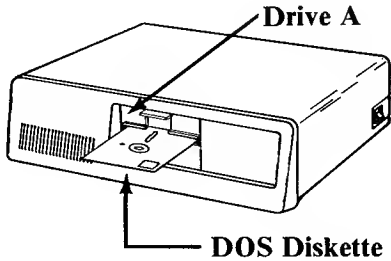

2. Press and hold Ctrl and Alt, then press Del. Then release them all:



3. You will see the diskette drive "in use" lamp light while DOS is being read, and you may hear some clicks and whirs.

Note: The action you have just performed is known as System Reset. It will be used again in the section "To Start DOS Again", which you would consult if another program was already loaded and you wanted to restart DOS.

DOS

Telling DOS the Date

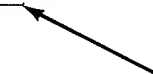

When DOS is loaded and ready, you will see something similar to this on the screen:

Current date is Tue 1-01-1980
Enter new date: _____

The cursor shows where the first number you type will appear.

It's an excellent idea to fill in the current date whenever you start (or restart) DOS because then, any files that you create or change, will have the correct date stored in the file directory - helpful information months later if you can't remember exactly which file has the most current information. (You'll learn about files and directories later.)

To set the date, use the number keys across the top of the keyboard:

1. Type one or two numbers between 1 and 12 for the month.
2. Type a dash  or a slash .
3. Type one or two numbers between 1 and 31 for the day.
4. Type another dash or slash.
5. Type the last two numbers of the year between 80 and 99 or a four-digit number between 1980 and 2099.
6. Press the Enter key .

For example, suppose the current date is June 8, 1982.

Type this: 6-8-82
or this: 6/8/82
or this: 6-08-82
or this: 6/08/82
or this: 06-08-82
or this: 06/08/82
or this: 06/8/82

DOS checks the form of the date you type. If the form is not correct, DOS displays this message:

```
Invalid date
Enter new date __
```

These are some dates that would not check out:

Date	Reason
060882	No dashes or slashes
APR-02-80	Letters instead of numbers
13-08-83	Month number too great
9-32-82	Day number too great
10 15 82	Spaces, not slashes or dashes

If DOS tells you that the date is invalid, try again. Or if you do not wish to enter a new date, then press the Enter key when the following is displayed:

```
Current date is 1-01-1980
Enter new date: __
```

Telling DOS the Time

After you have entered the date, DOS displays something similar to this:





Current time is 0:01:43.53

Enter new time: __

The time displayed is:

HOURS: MINUTES: SECONDS. HUNDREDTHS OF SECONDS

To set the time, use the number keys across the top of the keyboard:

1. Type one or two numbers between 0 and 23 for the hours.
2. Type a colon  .
Note: A dash  or a slash  will not work.
3. Type one or two numbers between 0 and 59 for the minutes.
4. Type another colon.
5. Type one or two numbers between 0 and 59 for the seconds.
6. Type a period  to separate seconds and hundredths of seconds.

Note: Only a period will work.

7. Type two numbers between 0 and 99 for the hundredths of seconds. This step is optional.

8. Press the Enter key .

For example, suppose the time is 8:30 a.m. exactly.

Type this: 8:30:0.0
or this: 08:30:0.0
or this: 8:30

The DOS Prompt

DOS checks the form of the time that you type. If the form is not correct, DOS displays this message:

```
Invalid time
Enter new time: __
```

This is a time that would not check out:

Time	Reason
8/30/0/0	Only colons between hours, minutes, and seconds, and only a period between seconds and hundredths of seconds will work.

If DOS tells you the time is invalid, try again. However, if you do not wish to enter a new time, then press the Enter key when this is displayed:

```
Current time is 0:00:13.89
Enter new time: __
```

After you have entered the time, DOS displays this:

```
The IBM Personal Computer DOS
Version XXX (C)Copyright IBM Corp XXXX
A> __
```

A> is the DOS prompt. A prompt tells you that it is your turn to type information; that is, to tell DOS what to do by entering a command.

This prompt tells you some things other than that DOS is waiting for you to enter a command.

First of all it tells you that it is **DOS** that is waiting. Other programs have different prompts; for example, **BASIC's** prompt is: **Ok**. Ok lets you know that you should respond with a **BASIC** command.

Secondly, **A>** tells you that **A:** is the default drive. A default drive is the diskette drive that DOS assumes will contain the diskette or file you specify in a command, unless you explicitly type another diskette drive, such as **B**. Another name for the default drive is the current drive.

Changing the Default Drive

You can change the default drive by simply typing the new drive designator following the A> prompt, then pressing Enter.

For example, to make drive B the default drive, type:

b:

and press the Enter key. Here's what this looks like on the screen:

A>b:

B> _

 The cursor is here.

Note that now the prompt is B> - just what we wanted. Now DOS will look at the diskette in drive B whenever you specify a file without the drive designator.

You can change back to drive A by typing a:. Here's the screen now.

B>a:

A> _

Try this too.

So far we have discussed:

- How to get DOS started
- The DOS prompt and default drive

Let's take a closer look at the keyboard and diskettes before we go any further.

Controlling DOS

In addition to the keys you would find on a typewriter, your keyboard has some special keys you'll use with DOS.

Before we get to the special keys, here are a few differences you need to know about your keyboard and a typewriter.

Characters That Look Alike - "O's" and "0's" (zero), "1's" and "L's"

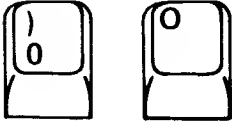

Computers are fussy about the number zero and the letter O - they want what they want, and you can't fool them into taking the wrong one. Make sure you type the right character in commands and file names.

On our printer, the letter O looks a little squarer than the number 0, and on our screen, the zero has a diagonal line through it, something like this: Ø

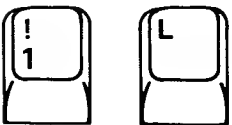

If you are used to typing a lowercase L for the number 1, you'll have to break that habit. Again, the computer knows the difference. Use the number key when the number 1 is required, as in a file name, such as DATA123. (If you were to use lowercase L when creating a file name, that's okay. Just be sure to use it again when you want to use that file.)

The Spacebar

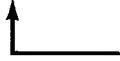

This is the spacebar. Use it to put a blank (a space) in a line you are typing. Sometimes people want to use it to move the cursor - it will move the cursor, but it will also replace any characters it moves across with blanks.

To the computer, blanks are important; a blank is as much a character as A or B. Many times blanks are used to separate what you type for the computer just as we use them to separate words in everyday writing. You have to make sure when you're typing that the computer allows a blank. Otherwise, it may not understand what you have typed.

The Shift and Caps Lock Keys

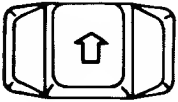

There are two Shift keys on the keyboard, and they are about where you find them on a typewriter keyboard. Use them to type uppercase (capital) letters, or to type the symbol shown in the upper portion of the keytops of all keys except the numeric keypad.



The Caps Lock key lets you type only capital letters until you press it again. Only the letter keys are affected. You still have to press one of the Shift keys for the symbols in the upper portion of the number keys at the top of the keyboard. For example, you must press the shift key to type a #.



Unlike a regular typewriter, pressing one of the Shift keys  does not get you out of Caps Lock state. You must press the Caps Lock key again to type lowercase letters, or you can press a Shift key to type a single lowercase letter.

Remember that DOS will accept lowercase letters in all commands and file names, so you'll be using the Shift keys mostly for special symbols.

To Enter a Command

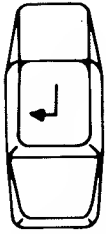

Use the Enter key when you have finished typing a whole command. After you press the Enter key, the command starts (sometimes, you will see the word “executed” instead of “started”).

To Stop a Command

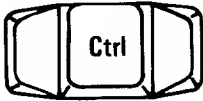

+



Press and hold the Ctrl (Control) key, then press the Break key. Then release both keys to stop a command from finishing its job normally. (This is sometimes called “terminating” a program.)

DOS then shows you a prompt, and you can type your next command.

To Correct a Typing Mistake

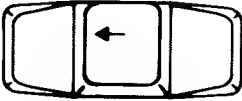

There are several ways to correct a mistake that you notice before you press the Enter key. One of the easiest is to use the Backspace key to move the cursor backward, to the leftmost wrong character. The Backspace key deletes characters as it moves the cursor to the left. (The Backspace key is in the top row next to the Num Lock key.) Now type the correct characters, then press the Enter key when everything is the way you want it.



If the line is just too messed up to worry about, you can press the Esc (Escape) key. A Backslash (\) appears, and the cursor moves down one line on the screen. This cancels the messed-up line and you can then type the command correctly.

More ways to correct typing mistakes (“editing”) are discussed in the *Disk Operating System* book; but these two keys should be enough to get you started.

To Stop the Screen Long Enough to Read It

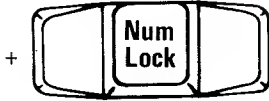
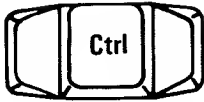

If information is appearing on the screen too fast for you to read, press and hold the Ctrl (Control) key and then press the Num Lock (Number Lock) key. Then release both of them. When you are ready to see more information, press any key.

("Scrolling" is the term used to describe how a line of information moves up and off the top of the screen and new lines of information appear below it.)

To Print What Is on the Screen

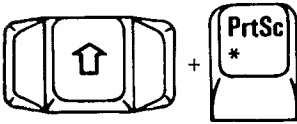

If you have a printer and want to print what is currently on the screen, first make sure the printer is on. Then press and hold either Shift key, then press the Prtsc (Print screen) key; then release both keys.

What is printed is often called a "hard copy."

To Print Whatever You Type

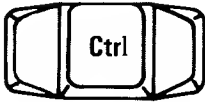

+



If you have a printer and want to print whatever you type and what the computer displays, press and hold the Ctrl (Control) key, then press the Prtsc (Print screen) key, then release them both. Now, each time you press the Enter key or the computer displays a line, the line will be printed ("echoed") at the printer.

To stop echoing to the printer, press the Ctrl and Prtsc keys again.

This is different from pressing the Shift and Prtsc keys. Shift and Prtsc print a whole screen's worth and nothing more. But Ctrl and Prtsc print one line at a time, line after line, until you press Ctrl and Prtsc again to stop the printing.

To Start DOS Again

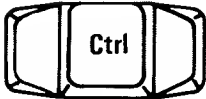

+



+



If you want to restart DOS from the beginning, put your DOS diskette into drive A. Then press and hold down the Ctrl (Control) and Alt (Alternate) key, press the Del (Delete) key, then release all three. Remember, you may see this called System Reset.

After a while, you'll see the DOS startup message.

About Diskettes

Your IBM Personal Computer uses 5-1/4 inch (133 mm) diskettes for storing information. (You may also have heard the terms “floppy diskette,” “mini-floppy,” or “disk” - we will use “diskette.”)

These diskettes can be either single-sided or double-sided. Single-sided diskettes can hold 163,840 characters and double-sided diskettes can hold 327,680 characters. That’s about 110 pages from a book for a single-sided diskette and 220 pages for a double-sided diskette. You cannot use the full capacity of the double-sided diskettes unless you have a 320K drive.

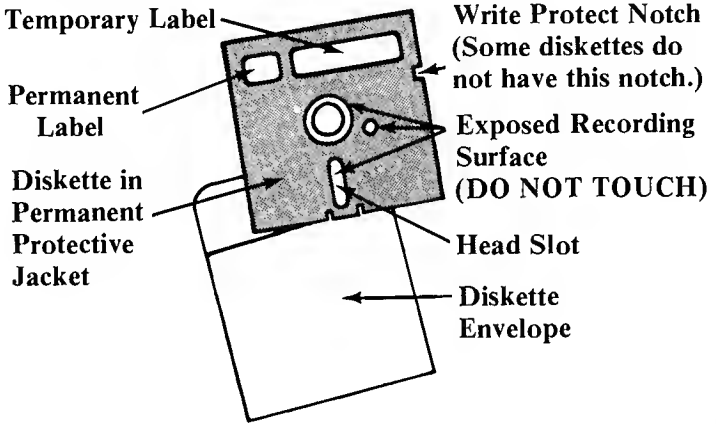

The permanent protective jacket (which is black) holds the flexible diskette, which is coated with a magnetic substance. When in use, the diskette spins inside the jacket. The read/write head comes into contact with the recording surface through the long hole in the protective jacket, called the head slot. Information is written to or read from the magnetic surface of the diskette, similar to the way an ordinary tape recorder operates.

The information on a diskette can be read by the computer as often as needed, or the computer can write new information on the diskette in an unused space. The computer may also replace old information with new information by writing over it. In this case, the old information is erased and can no longer be read. Similarly, if you record a Chicago Symphony program on an Elvis Presley tape, you can no longer listen to Elvis.

Tracks, Bytes, and Sectors

Information is written on the diskette along concentric circles called tracks. The read/write head of the diskette drive moves back and forth from one track to another as the diskette spins over it. This lets the head find certain data to read, or find a place to write some new information.

There are 40 tracks on a diskette, numbered 0 to 39. DOS reserves portions of track 0 of each diskette. The rest of the diskette is available for your information and for a copy of the DOS system, if you so wish.

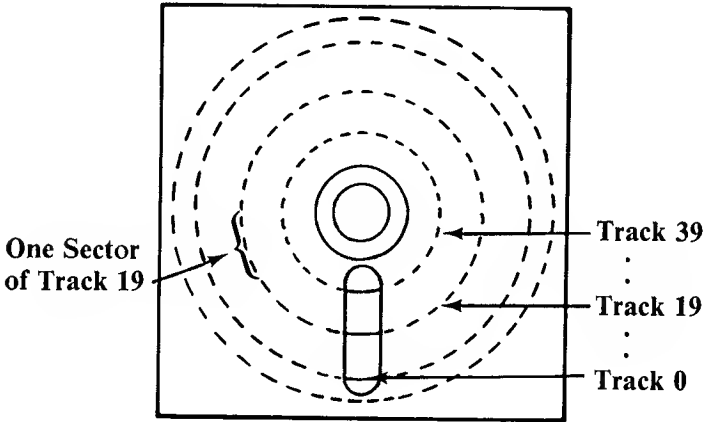

You'll also hear the words byte (pronounced like "bite") and sector used in talking about diskettes.

Space on a diskette (and the computer's memory, too) is measured in bytes. One byte can hold one character; thus, the single-sided 5-1/4 inch diskettes can hold 163,840 bytes, or 163,840 characters, and the double-sided diskettes can hold 327,680 bytes or 327,680 characters.

Each track is divided into eight sectors that are 512 bytes long. One or more sector's worth of information can be sent back and forth between the computer and a diskette at one time.

Information on a diskette can be quickly located by its side, track, and sector numbers - just as the Post Office can locate your home by using the town (side number 0 or 1), street name (track number), and the house number (sector number).

Normally, you won't have to know about the information's sector, track, and side numbers - DOS takes care of that for you. You give your information a name, called a filename, and DOS assigns it to a place on your diskette.

"Files and Filenames" are discussed after we tell you a little more about protecting the information on your diskettes - especially your DOS Diskette.

Careful Does It

Be careful with your diskettes. Section 4 explains how to handle your diskettes, but we'd like to emphasize the following:

- Do not touch the exposed recording surfaces.
- Protect the diskettes from dust by returning them to their envelopes as soon as you remove them from the diskette drive.
- Store often-used diskettes in their envelopes. Don't lay heavy objects on top of them. If you stand them on edge, make sure they aren't bending or sagging.
- Store seldom-used diskettes in storage boxes, away from heat and magnetic field sources such as telephones, dictation equipment, and electronic calculators.
- Because each piece of information occupies such a tiny spot on the diskette, small scratches, dust, food, or tobacco particles may make the information unusable.

Take care of your diskettes, because trying to run your computer without programs and data is like trying to run your car without gasoline.

Write-Protect Notch

Besides making sure your diskettes aren't scratched or dirtied, you can make sure the computer cannot write over information already on a diskette.

If your diskette has no write-protect notch, it is already write protected. This means that the computer cannot store (write) any information on it. Your DOS diskette does not have a write-protect notch.

If your diskette has a write-protect notch, you can cover this notch with a tab supplied with the diskette. Then the computer cannot write on the diskette. In this case, information can only be read. Information already on the diskette cannot accidentally be erased by being overwritten with new information.

Important diskettes (for example, purchased program diskettes) are often protected this way.

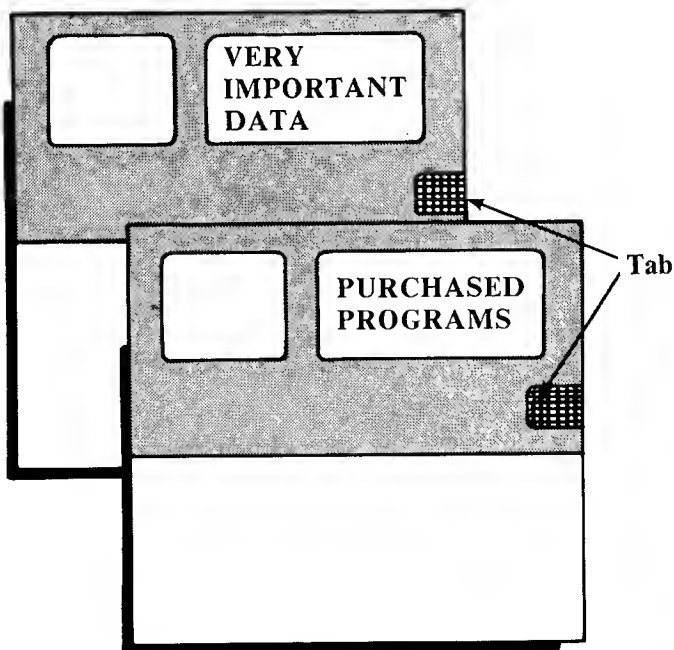

Just for Reading

If you are certain it is okay to write on a write-protected diskette, you can peel off the tab so that the computer can write on it.

An Important Exercise: Backing Up Your DOS Diskette

Making a copy of your DOS diskette should be one of the first things you do with your IBM Personal Computer after you get DOS. Then you won't be "shut down" if your DOS diskette becomes misplaced or accidentally damaged. This copy is called a backup copy, and making the copy is usually called backing up.

Before You Begin

You will need:

- Your DOS diskette.
- A diskette, preferably brand new, that will become the backup. (If the diskette has been used before, make sure that it does not contain information you will need again. This procedure will destroy any information that was stored on the diskette.)

We will refer to this diskette as the backup diskette in the two examples that follow.

Read through the instructions before you start. There are two sets of instructions - one set for systems with one diskette drive, and another set for two diskette drives.

If You Have One Drive

1. Make sure DOS is ready and A> is displayed.
2. Insert your DOS diskette into the drive, if it is not already there.
3. Type:

diskcopy

and press the Enter key.

4. This message appears:

Insert source diskette in drive A

Strike any key when ready

Because the DOS diskette (the “source diskette”) is already in drive A, you do not need to exchange diskettes.

5. Press a key.
6. Now this message appears:

Copying 1 side(s)

Insert target diskette in drive A

Strike any key when ready

Before touching any key:

- 6A** Remove the DOS diskette.
- 6B** Insert the backup (target) diskette.
- 6C** Now press a key to tell DOS the correct diskette has been inserted.

- 7.** In a short time, this message appears:

Formatting while copying

Insert source diskette in drive A

Strike any key when ready

Note: The formatting message appears only when the backup diskette has never been used.

Do this:

7A Remove the backup diskette.

7B Insert the DOS diskette.

7C Press a key only after the DOS diskette is in the drive.

- 8.** Keep repeating Steps 6 and 7 until this message appears:

Copy complete

Copy another? (Y/N)

- 9.** Type:

n

You don't have to press the Enter key.

- 10.** Type:

diskcomp

and press the Enter key.

11. This message appears:

Insert first diskette in drive A

Strike any key when ready

12. Insert your original DOS diskette in drive A and press any key.

13. Now this message appears:

Comparing 1 side(s)

Insert second diskette in drive A:

Strike any key when ready

Do this:

13A Remove the DOS diskette.

13B Insert the backup diskette.

13C Press a key.

14. Now this message appears:

Insert first diskette in drive A

Strike any key when ready

Do this:

14A Remove the backup diskette.

14B Insert the DOS diskette.

14C Press a key.

- 15.** Keep doing Steps 13 and 14 until the following appears:

Diskettes compare ok

Compare more diskettes (Y/N)?

Hint: In this portion of the exercise you can remember which diskette to insert if you remember that your original DOS diskette was your “first” diskette.

- 16.** Type:

n

- 17.** The DOS prompt, A>, appears.

Remove the diskette from the drive.

With a felt-tip pen, label and date your “DOS DISKETTE BACKUP.”

Store the original DOS diskette correctly and use the backup in your daily operations. In the rest of this chapter, we will still call the backup diskette “your DOS diskette,” because it is the same as your DOS diskette.

If You Have Two Drives

1. Make sure DOS is ready and **A>** is displayed.
2. Insert your DOS diskette into drive A if it is not already there.
3. Insert the backup diskette into drive B.
4. Type this:

diskcopy a: b:

and press the Enter key.

5. You will see this message:

Insert source diskette in drive A

Insert target diskette in drive B

Strike any key when ready

Your diskettes have already been inserted into these drives. (That is, the DOS diskette is in drive A, and the backup "target" diskette is still in drive B.)

6. Press any key to tell DOS the diskettes are ready. You will see this message:

Copying 1 side(s)

Formatting while copying

Note: The formatting message appears only when the backup diskette has never been used.

Now the entire diskette is being copied from the diskette in drive A to the diskette in drive B. You will see one "in use" light go on and then the other.

7. When the copy has been made, you will see a message similar to this:

Copy complete

Copy another? (Y/N)

The cursor is here.



8. Type:

n

The DOS prompt, A>, is displayed.

9. Just to make sure the copy is the same as the DOS diskette, we will compare them.

Type:

diskcomp a: b:

and press the Enter key.

10. This message appears:

Insert first diskette in drive A

Insert second diskette in drive B

Strike any key when ready

The cursor is here.



When you press a key, this message appears:

Comparing 1 side(s)

11. Again you will see the “in use” lights come on and hear some clicking. When the comparison is complete, this message is displayed:

Diskettes compare ok

Compare more diskettes (Y/N)?

← The cursor

12. Type:

n

13. Remove both diskettes.

Label and date the backup diskette. Use a felt-tip pen. Store the original DOS diskette correctly and use the backup diskette in your daily operations.

What's on the DOS Diskette?

If you've read this far and done the exercise, you have made a copy of your DOS diskette for everyday use, and you've learned something about diskettes.

Let's take a closer look at the DOS diskette to find out what information is on it. Before we get to the exercise to do this, we will discuss how information is structured on a diskette.

Files and Filenames

Related information on a diskette is grouped into files, just as information in a book about a particular topic may be grouped into a chapter.

Some examples of files:

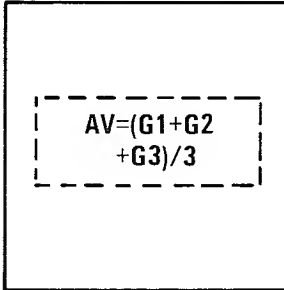

A file containing a program to calculate bowling team averages.

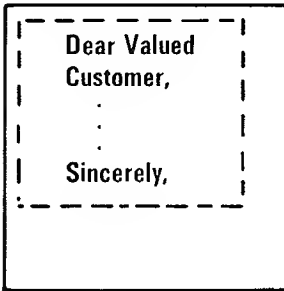

A file containing the text of a form letter your company sends out.

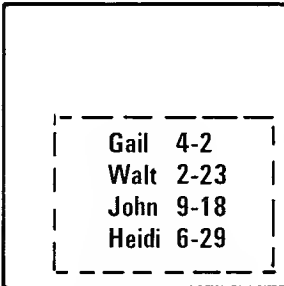

A file containing names and birthdays of your friends.

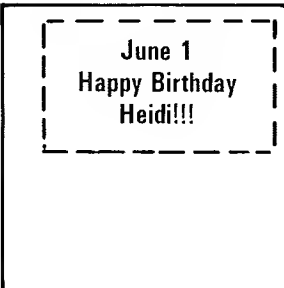

A file containing a program to print a birthday message to all your friends born this month.

Files are used so DOS can find specific information easily, and information not needed isn't taking up room in the computer. (For example, you don't need your bowling team averages at the same time as you need the form letter.)

You usually have a number of files on a diskette. You can have up to 64 files on a single-sided diskette and 112 files on a double-sided. Sometimes the files on one diskette are related to each other (like the programs and data files to keep track of a company's inventory), and sometimes the files have been put on whatever diskette was handy.

It doesn't matter what combination of files is on a diskette. What matters is that each file has a unique name. This means that every name on a diskette must be different - but you can have the same name on two different diskettes.

For the examples given earlier, the names of the files might be:

**BOWL
LETTER
BIRTHDAY
BIRTHDAY.BAS**

A file's name is made up of a filename and an extension.

In DOS, filenames are from one to eight characters long. The characters in a filename can be:

- the letters of the alphabet
- the numbers 0 through 9
- and these special characters -

`$ # & @ ! % () - { } < > ' _ \ ^ ~ | '`

A filename can be followed by an optional short name called an extension. An extension starts with a period, has one, two, or three characters, and follows immediately after the filename.

Here are some filenames with extensions:

81PRICES.JUL
81PRICES.AUG
AVRG.\$&%
WEATHER.80

IMPORTANT: If a filename is followed by an extension, you must use both parts when telling DOS about that file.

Bad, Okay, and Good Names for Files

With all the possibilities, filenames can be unusual, to say the least.

DOS likes names that follow the rules. These files have names that DOS will not accept:

Name	Why DOS won't accept it
A AND B	Spaces
A,B, & C	Commas
.PGM	Filename missing
ANDTHISONEISTOO.LONG	

These names are okay for DOS:

()<<>>().XXX
#1#2#A3B
@@.---
Z

but can you guess what is in any of these files?

A good name for a file will help you remember what kind of information is in the file and, perhaps, whether it's a file that contains a program or only data. For example, **ADDRLIST.BAS** is a good name for a BASIC program file that prints an address list.

File Specifications

When looking for information, DOS needs to know in addition to the filename, which drive has the diskette with that particular file.

The drive specifier is a letter and a colon, like A:, and it tells where the file is. You must always type the colon after the drive specifier letter.

The filename and extension immediately follow the drive specifier, like this:

A:81PRICES.JUL

Don't put any spaces between the three parts. These three parts - the drive specifier, the filename, and the extension - are called a file specification.

If the drive specifier is the same as the default drive, you don't have to type the specifier. For example, assume A is the default drive (remember, you can tell by looking at the prompt - A> in this case). Then you could type:

a:address **OR** address **Look - no drive specifier!**



They are exactly the same to DOS when A is the default drive.

Here are some more file specifications:

A:81PRICES.AUG

A:KIKI.J

B:BOWL.BAS

B:MINE

YOURS ← **With this kind of file specification, DOS assumes that the file (YOURS) can be found on the default drive.**

Global Filename Characters

Sometimes you will want to do the same thing with several files - for example, copying a group of files at one time, or listing the names of a group of files that are somehow related.

Two special global filename characters let you indicate a number of files with one specification. These characters are the question mark (?) and the asterisk (*). They are used in a filename or an extension to mean "any character."

These characters can save you a lot of typing if your files are named appropriately. Let's see how you can use global filename characters.

In the examples that follow, you need to know that the DOS command DIR displays information about files that match the file specification you type.

The ? Character

A ? in a filename or extension means that *any* character can be in that position. So, all filenames that are the same except for the ? positions can be selected.

Suppose the diskette in drive A has these files on it:

79PRICES.AVG
80PRICES.AVG
81PRICES.JAN
81PRICES.JUL
81PRICES.AUG
79INVTRY

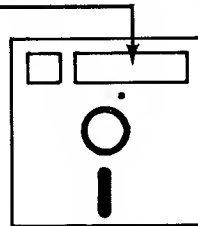

If you type:

```
dir ??prices.???
```

all the files except the last one (79INVTRY) are listed on the screen.

These are the files that match and are listed:

79PRICES.AVG
80PRICES.AVG
81PRICES.JAN
81PRICES.JUL
81PRICES.AUG

For another example, suppose you give DOS this command:

```
dir ??prices.a?g
```

Then these files match and are listed:

79PRICES.AVG
80PRICES.AVG
81PRICES.AUG

The * Character

An * in a filename means that any character can be in that position and in the rest of the filename. Likewise, an * in an extension means that any character can be in that position and in the rest of the extension. Using an asterisk is like typing several ?'s, but shorter. Unlike ?, two or more * are never used together. One is enough!

Assume that the same diskette we used in "The ? Character" is in drive A.

If you give DOS this command:

```
dir 81*.j*
```

then these files are selected and displayed:

81PRICES.JAN
81PRICES.JUL

For another example, if we tried:

```
dir 8*.*
```

These files would be listed:

```
80PRICES.AVG
81PRICES.JAN
81PRICES.JUL
81PRICES.AUG
```

And if you type:

```
dir *.*
```

all the files would be listed.

You can use both global filename characters together. For example, if you type:

```
dir ??p*.a*
```

you would see these files listed:

```
79PRICES.AVG
80PRICES.AVG
81PRICES.AUG
```

Global characters are fun, but you need to be careful both in naming your files and in using them - you may get results you don't expect!

For You to Try

Insert your DOS diskette in drive A and type:

```
dir *.com
```

then press the Enter key.

Now try this:

```
dir ????????.com
```

and press the Enter key.

Type this:

```
dir c*.com
```

and press the Enter key. Did you see three files listed?

An Exercise: Listing the DOS Diskette Files

Here's something for you to do right now - use the DIR command to find out the names of the files on the DOS diskette. This exercise also teaches you how to print a directory listing. If you don't have a printer, do the parts you can, and read along for the rest.

Before You Begin

Get your DOS diskette, and make sure your printer is on, is online, and has paper.

Let's Go

1. Make sure DOS is ready and **A>** is displayed.
2. Press and hold the Ctrl key, then press the Prtsc key.

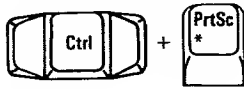

This will cause the printer to print everything that appears on the screen.

3. Insert your DOS diskette into drive A.
4. Type:

```
dir
```

and then press the Enter key.

5. When your DOS diskette directory has been completely displayed and printed, tear off the listing and look for these files:

ART	.BAS	DONKEY	.BAS
SAMPLES	.BAS	CIRCLE	.BAS
MORTGAGE	.BAS	PIECHART	.BAS
COLORBAR	.BAS	SPACE	.BAS
CALENDAR	.BAS	BALL	.BAS
MUSIC	.BAS	COMM	.BAS

These are the names of the sample program files. You can learn how to run these programs in "Using BASIC - Running the SAMPLES Program" in the next chapter of this section.

6. Now hold down the Ctrl key and press the Prtsc key. This stops the printer from printing what is displayed.

DOS Diskette Files

Here is a list of the files that are on the DOS diskette. This list may not be in the same order as your directory list, and of course, you don't see two columns of names.

COMMAND	.COM	BASICA	.COM
FORMAT	.COM	ART	.BAS
CHKDSK	.COM	SAMPLES	.BAS
SYS	.COM	MORTGAGE	.BAS
DISKCOPY	.COM	COLORBAR	.BAS
DISKCOMP	.COM	CALENDAR	.BAS
COMP	.COM	MUSIC	.BAS
EXE2BIN	.COM	DONKEY	.BAS
MODE	.COM	CIRCLE	.BAS
EDLIN	.COM	PIECHART	.BAS
DEBUG	.COM	SPACE	.BAS
LINK	.COM	BALL	.BAS
BASIC	.COM	COMM	.BAS

There are two other files on your DOS diskette but they won't appear in a directory listing:

IBMBIO	.COM
IBMDOS	.COM

These files are important because they're the foundation for the IBM Disk Operating System.

Things You Can Do with DOS

The rest of this chapter summarizes commands used for everyday tasks. Read the chapter now to familiarize yourself with these commands and refer to them when you need to perform a specific task.

Just remember, you will have to substitute the names of your own files for those we have used here - it's that easy.

Summary of Commands

These are some of the DOS commands. Those marked with an asterisk (*) will be discussed in the next section.

Command	Function
CHKDSK	CHecK DiSK makes sure the specified diskette's files and directory match, and gives you a report about the status of the diskette and memory.
COMP	COMParE compares the contents of two files with each other and tells you if there are differences.
* COPY	COPY copies the file(s) you specify to the same or another diskette.
DATE	DATE lets you store a date in the computer.
* DIR	DIRectory displays a list of all the files with names that match the name you specify.
* DISKCOPY	DISK COPY puts a copy of an entire diskette on another diskette. It runs somewhat faster than COPY when backing up an entire diskette.

Command	Function
DISKCOMP	DISKette COMPare compares the contents of two diskettes and tells you if they don't match.
* ERASE	ERASE deletes (gets rid of) the file(s) you indicate.
* FORMAT	FORMAT gets a new diskette ready to be used and, optionally, copies DOS to it.
* MODE	MODE lets you change the amount of information displayed on the screen or printed on the printer, sets options for the asynchronous communications adapter, or causes printer output to be routed to the asynchronous communications adapter. It also lets you shift the information on the screen a few positions to the right .
* RENAME	RENAME lets you change the name of a file.
SYS	SYStem transfers a copy of DOS to another diskette.
TIME	TIME lets you set a clock in the computer.
* TYPE	TYPE displays the contents of a file on the screen.

Once you have gotten acquainted with the DOS commands in this chapter, go to the *Disk Operating System* book for more information on all the commands.

Resident Commands

Most of the commands are actually programs that are on the DOS diskette. However, a few of the more frequently used commands are resident, that is, they are always in computer memory and available as you need them. For resident commands you do not need to first insert the DOS diskette. The resident commands are:

COPY
DIR
ERASE
RENAME
TYPE

Giving DOS a Command

To give DOS a command:

1. Wait until you see the DOS prompt, **A>**.
2. Type the command and any other parts the command requires (for example, a drive specifier or a file specification).

You can type in uppercase or lowercase (or a combination). Use a blank (the spacebar) to separate the parts of the command from each other.

3. Press the Enter key when you have finished typing.

FORMAT - Getting a Diskette Ready to Be Used

The FORMAT command gets a diskette ready to receive information. FORMAT checks the diskette for bad spots, builds a directory to hold information about the files that will eventually be written to it, and optionally, copies the DOS system files onto the diskette.

Depending on the publication, you may see the terms "initializing" or "preparing" being used instead of "formatting".

You must use FORMAT before you try to use a new diskette, unless you are copying from another diskette using the DISKCOPY command.

You can use FORMAT if a diskette has developed defective areas. FORMAT makes sure these areas are not used for your files. FORMAT and CHKDSK will tell you if there are defective areas on your diskette.

You can also use FORMAT as a way to prepare a diskette that has information you no longer need.

DO NOT use FORMAT each and every time you want to put information on a diskette, because FORMAT wipes off what was there already.

To sum up, you need to use FORMAT once per diskette, when it is new. Very occasionally you will re-FORMAT a diskette if it has defective areas or if you want to forget what was on it and use it as if it were new.

Before You Begin

Have on hand your DOS diskette and the diskette you want to format.

Also decide if you want a copy of DOS on your new diskette. Sometimes you will want DOS on a diskette if you will be putting major programs on it. On the other hand, if the diskette is going to be used for data files, you will probably not want DOS on the diskette.

If You Want DOS on Your Diskette

With One Drive

1. Make sure DOS is ready and **A>** is displayed.
2. Insert your DOS diskette into drive A, if it is not already there.
3. Type:

```
format a:/s
```

and press the Enter key.

Note: If the target diskette is double-sided, this will create a diskette for dual-sided use only. If you want to format a diskette that can be used in either a single-sided or double-sided drive, then type:

```
format a:/s/1
```

4. Now you will see this message:

**Insert new diskette for drive A:
and strike any key when ready**

5. When the drive A “in use” light is off, remove the DOS diskette from drive A.
6. Put your new diskette in drive A.
7. Press any key - the spacebar for instance.
8. You will see this message:

Formatting . . .

9. After some whirring and clicking, you will see this:

**Formatting . . . Format complete
System transferred
xxxxxx bytes total disk space
13824 bytes used by system
yyyyyy bytes available on disk
Format another (Y/N)?**

10. Type:

n

You don't have to press the Enter key.

11. Now you will see the DOS prompt, **A>**, and you can remove your newly formatted diskette.

The diskette is now ready to be used. It has a copy of DOS on it (that's because in Step 3 you typed /s - the “s” stands for “system”).

If You Do Not Want DOS on Your Diskette

If you don't want DOS on your diskette, then in Step 3, type:

format a:

or **format a:/1** for single-sided format

and press the Enter key. Then the line that says "System transferred" (Step 9) does not appear.

Formatting Several Diskettes

If you want to format several diskettes in a row, follow Steps 1 through 9, but do this at Step 10.

10. Type:

y

(You probably already guessed.)

You will again see the message shown at Step 4. Follow the same steps for each diskette you want to format at this time.

With Two Drives

If you have two diskette drives, insert your DOS diskette into drive A, and put your new diskette into drive B.

Then, for Step 3, type:

format b:/s
(**format b:/s/1** for single-sided)
or **format b:**
(**format b:/1** for single-sided)

depending on whether you want DOS on your diskette.

In Step 4, the message is now going to be:

**Insert new diskette for drive B:
and strike any key when ready**

The rest of the steps are the same except you will not have to remove the DOS diskette.

DIR - Finding Out What Is on a Diskette

It is often useful to find out what files are on a diskette - perhaps because you need to know how a particular filename is spelled, or because you can't recall what's on a seldom-used diskette.

The Directory command (DIR) displays a list of all the files that match a name you specify. You've seen this command before in the section "Global Filename Characters." Let's see how you might use it.

Before You Begin

All you need for DIR is the diskette for which you want to see the directory.

To List All the Files

With One Drive

1. Make sure DOS is ready and **A>** is displayed.
2. Remove the DOS diskette from drive A, if it is there.
3. Insert into drive A the diskette whose directory you want to list.
4. Type:

`dir`

and press the Enter key.

5. Watch the screen.

The screen displays the filename, the extension, the size of the file (in bytes), and the date and the time that information was last written in the file. One line is displayed for each file on the diskette.

Remember, if the information is moving too fast for you to read, press and hold the Ctrl key, then press the Num Lock key. Then press another key when you're through reading to start displaying again. It is also a good idea to print a copy of a diskette's directory (Ctrl + Prtsc) to keep with the diskette.

6. When all the files have been listed, the DOS prompt, **A>** appears.

With Two Drives

If you have two diskette drives, you can keep the DOS diskette in drive A, if it is there, and insert your diskette in drive B. Then at Step 4, type:

```
dir b:
```

and press the Enter key.

You have to tell DOS where to find the diskette - in this case the one in drive B. Otherwise, DOS assumes you mean the default drive diskette.

To List One File

With One Drive

For this example, let's assume that you think you have filename FACT&FIG on a diskette. Here's how you make sure:

1. With DOS ready (A> is displayed), insert the diskette into drive A.
2. Type:

```
dir fact&fig
```

and press the Enter key.

3. If FACT&FIG is indeed on the diskette, its filename (FACT&FIG), its extension (in this case, none), its size, and its update date and time are shown.

If the diskette does not have a file named FACT&FIG, then after a second or two the following message is displayed:

```
File not found  
A>_
```

With Two Drives

You can insert the diskette with the file into drive B and type for Step 2:

```
dir b:fact&fig
```

Now press the Enter key.

Here the only difference is that you have to tell DOS where (what drive) the file is.

DISKCOPY - Backing Up a Diskette

Backing up a diskette means to make a copy of one diskette's data on another diskette. Similarly, backing up a file means to make a copy of a file (usually on a different diskette). (Backing up one file is discussed in the next part of this chapter.)

A backup, that is, the copy, saves you the time, trouble, and, sometimes, the expense of recovering the information on a diskette that has been lost, damaged, or accidentally written over. A backup often saves your temper, too.

It is a good habit to back up your important program diskettes as soon as you purchase or create them. Then, properly store your original diskettes in a place where you can find them if you need to, and use the backup diskettes for everyday operations.

Note: Some purchased program diskettes cannot be copied. In these cases, the documentation that comes with the programs will explain the best methods of backing them up.

Your data diskettes should be backed up every time you add or change information on them.

Before You Begin

You will need these diskettes:

- The diskette you want to back up - we're going to call this your "original" diskette.
- The diskette that will become the "backup" diskette, also called the "target" diskette.

Protecting Your Original Diskette

Hint: It's a good idea to put a tab over the write-protect notch to make sure your original diskette is not accidentally written on. Then you can remove it when the backup has been made, if you want to.

If the diskettes get mixed up when the write-protect notch is covered, a message similar to the following appears:

```
Target diskette write protected
Correct, then strike any key
```



The cursor is here.

If you get this message:

1. Remove the original diskette from the drive.
2. Insert the backup diskette in the drive.
3. Type:

r

(You do not have to press the Enter key.)

Backing Up with One Drive

If you have only one diskette drive, you must remove the original diskette and insert the backup diskette. You will have to make this switch (“swap”) four or more times. The number of times you have to swap diskettes depends on whether you’re using DISKCOPY or COPY, on how large the files being copied are, and on how much memory your computer has.

DOS will tell you when you have to swap diskettes. DISKCOPY will give you these messages:

Insert source diskette in drive A

Insert target diskette in drive A

So you should:

Insert	When
Original diskette	“source” message is displayed
Backup diskette	“target” message is displayed

- 1.** Make sure DOS is ready and **A>** is displayed.
- 2.** Insert the DOS diskette into the drive, if it is not already there.
- 3.** Type:

diskcopy

and press the Enter key.

- 4.** This message appears:

Insert source diskette in drive A

Strike any key when ready

BEFORE YOU PRESS A KEY:

4A Remove the diskette that is in the drive.

4B Insert your original diskette into the drive.

4C Now press a key.

- 5.** You will see the “in use” light come on while the original diskette is being read, and then this is displayed:

Insert target diskette in drive A

Strike any key when ready

BEFORE TOUCHING A KEY:

5A Remove your original diskette.

5B Insert the backup diskette.

5C Now press a key to tell DOS the correct diskette has been inserted.

- 6.** You will see the “in use” light come on while the backup diskette is being written. Then the message shown in Step 4 will appear again.

Hint: For this procedure, you can remember which diskette to insert if you remember “Original = Source.” Insert your original diskette when DISKCOPY asks for the source diskette.

7. Keep repeating Steps 4 and 5 until this message appears:

Copy complete

Copy another (Y/N)?

8. Type:

n

You don't have to press the Enter key.

9. The DOS prompt, **A>**, is displayed.

Remove the backup diskette from the drive. With a felt-tip pen, mark the label with the contents, the date, and perhaps the word "Backup."

Backing Up with Two Drives

1. Make sure DOS is ready and **A>** is displayed.
2. Insert your DOS diskette in drive A.
3. Type:

diskcopy a: b:

and press the Enter key.

4. You will see this message:

Insert source diskette in drive A

Insert target diskette in drive B

Strike any key when ready

5. Remove your DOS diskette from drive A.
6. Insert your original diskette in drive A.

7. Insert your backup diskette in drive B.

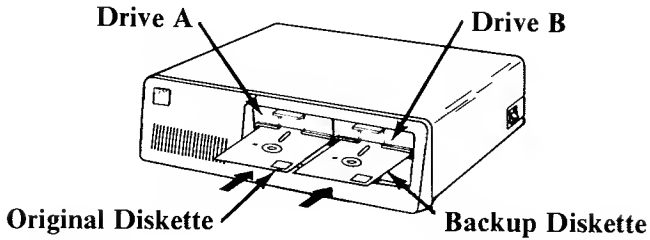

8. Press a key.

This tells DOS you are ready and this message is displayed:

Copying 1 side(s)

Formatting while copying

9. Now all information is being copied from the diskette in drive A to the diskette in drive B.

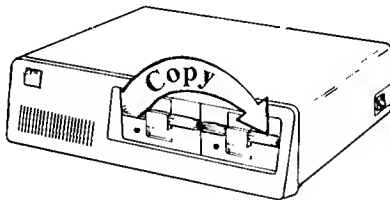

You will see the "in use" lights alternate between drives.

- 10.** When the copy has been made, this message will appear:

Copy complete

Copy another (Y/N)?



The cursor is here.

- 11.** Type:

n

and press the Enter key. The DOS prompt, **A>**, is displayed.

- 12.** Remove both diskettes.

Use a felt tip pen to label and date the backup diskette. You may also want to write "Backup" on the label to remind yourself that this is a copy of another diskette.

COPY - Backing Up One File

Sometimes you will find it useful to copy only one file. You might want to copy one file instead of a whole diskette when:

- Only one file of a whole diskette has been changed and needs to be backed up.
- You want to make extensive changes to a file, or you're not too sure of the effect of changes. It is safer to change a copy of the file than to change the original.
- You want to build a new file based on the contents of an old file - similar to copying a letter and then marking up the copy to make a new letter.
- You need two copies of a file. For example, if you want to give a friend a program you wrote, you'd probably want to give a copy of the program and not your original program.

Let's use some diagrams to illustrate the various possibilities with COPY.

Assume that two of the files on the original diskette are LJCORS and DIARY, and that the file to be opened is LJCORS.

- The file (LJCORS) is copied to another diskette, and the same name is used on both diskettes:

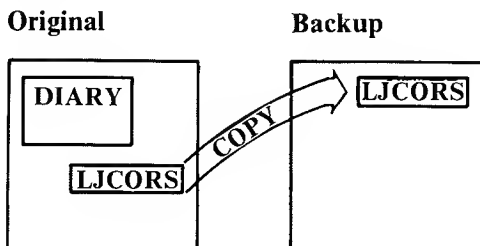

- The file (LJCORS) is copied to another diskette and the name of the copy is changed:

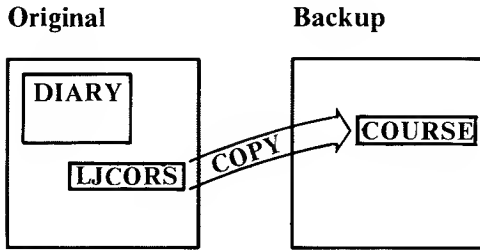

- The file (LJCORS) is copied to the original diskette with a changed name:

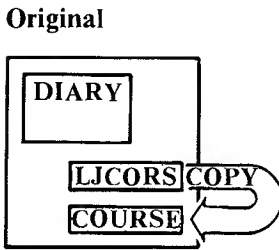

- The file (LJCORS) is copied to the original diskette with a name that is already being used:

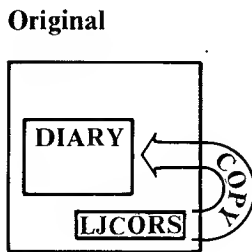

The information that was in DIARY is **replaced** by a copy of the information in LJCORS.

Before You Begin

Decide which kind of copy you want to make. Then get:

- The diskette with the file you want to copy. We'll call this the "original" diskette.
- The diskette that will have the copy of the file when you are done. This may be the same diskette as your original diskette, or it may be a different one, in which case we will call it your "backup" diskette.

Also decide on the name for the copied file.

Copying a File to the Same Diskette

For this example, let's assume that **LETTER** is the name of the file you want to copy, and that the copy's name will be **MEMO**.

Recall that you need a different name because every name on a diskette must be unique. You might want to check that the name you have chosen isn't already being used, unless you really mean to **replace** that file. For this example, check by typing: `dir memo`.

Let's do it:

1. Make sure DOS is ready and **A>** is displayed.
2. Insert the original diskette (the diskette with **LETTER**) in drive A.
3. Type:

```
copy letter memo
```

and press Enter.

Notice that in the command, you type the original filename first and the backup filename second. Separate the filenames with a space.

4. After a while (depending on how long the file LETTER is), you will see this on the screen:

```
1 File(s) copied
```

```
A>
```

5. LETTER has been copied, and the copy has been given the filename MEMO.

You can use the DIR command to check, by typing:

```
dir memo
```

Now press the Enter key.

6. Remove the diskette and put it away in its envelope, because we are through with this example.

Copying a File to Another Diskette Using One Drive

Remember, with only one diskette drive, you will need to exchange diskettes while COPY is running. DOS will tell you when the change must be made by showing you a message.

The messages for COPY sound as if you had two drives instead of one. You should think of the messages as referring to diskettes instead of drives.

For our examples, think of your original diskette as the “drive A” diskette, and the backup diskette as the “drive B” diskette. (Even though you have no drive B, the command is the same for one drive or two. The computer keeps track of the real drive A and the “imaginary” drive B.)

If you had two drives

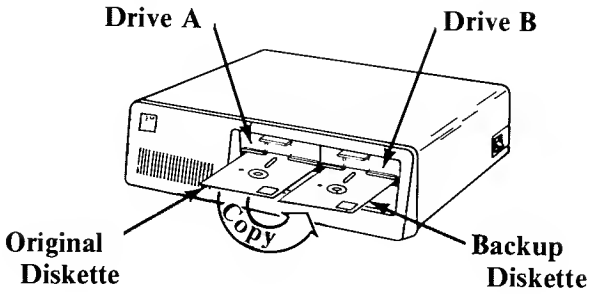

But with one drive

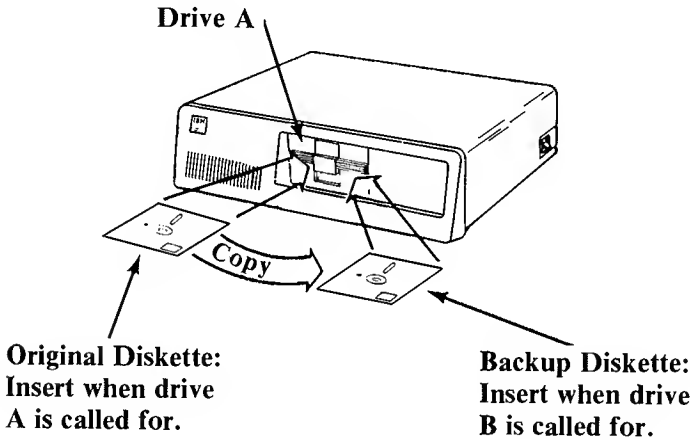

So you should:

Insert	When
Original diskette	"drive A" message appears
Backup diskette	"drive B" message appears

Let's assume that the file you want to copy is LETTER.
For this example, we are going to copy LETTER to
another diskette without changing its name.

1. Make sure DOS is ready and A> is displayed.
2. Insert the diskette with LETTER (the original diskette) into your drive.

3. Type:

copy letter b:

and press the Enter key.

Notice again where the spaces are.

4. This message is displayed:

Insert diskette for drive B: and strike
any key when ready

5. Remove the original diskette. (But don't put it away - you may need it soon.)
6. Insert the backup diskette in drive.
7. Now press a key to tell DOS that the diskettes have been switched.
8. Depending on the size of the file being copied (LETTER, in this example) and your computer's memory, you may see this message:

Insert diskette for drive A: and strike
any key when ready

If you do see the message:

8A Remove the backup diskette from the drive.

8B Insert the original diskette in the drive.

8C Press a key.

8D Now go back to Step 4.

Hint: It's easier to remember which diskette to insert if you think "**B** is for **backup**." Insert the backup diskette when the drive **B** message appears.

- 9.** When the copy has been made, this message is displayed:

1 File(s) copied

A> _

- 10.** Remove the backup diskette from the drive and label it with a felt-tip pen.

- 11.** Now you can put both diskettes away - LETTER has been copied to the second diskette.

For You to Try

Select a file on your DOS diskette to copy to another diskette - how about DONKEY.BAS? Keep the name the same (unless the diskette you'll put the copy on already has a file called DONKEY.BAS).

Copying a File to Another Diskette Using Two Drives

Let's assume you want to copy LETTER (again!). But this time, you want to put the copy on another diskette.

What name do you want it to have? For this example, we have picked the filename CORESPND for you. Here are the steps:

1. Make sure DOS is ready and A> is displayed.
2. Insert the diskette with LETTER on it into drive A.
3. Insert the diskette that you want the copy (CORESPND) to be written on, into drive B.

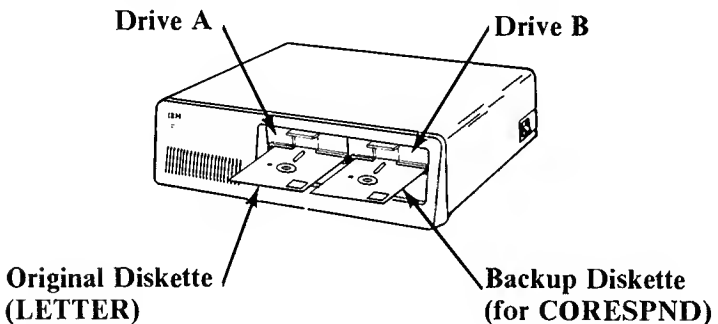

4. Type:

```
copy letter b:corespnd
```

and press the Enter key.

Notice the spaces between “copy” and “letter” and between “letter” and “b:corespnd”. Do not put a space between “b:” and “corespnd”.

Also notice that you must indicate the diskette drive (b:) of the copy diskette because it is not the same as the default drive. (Look back at “The DOS Prompt” for information about the default drive.)

- 5.** One “in-use” light will come on and then the other.

When the copy has been made, this is displayed:

1 File(s) copied

A> _

- 6.** You can now remove both diskettes and use a felt-tip pen to label the backup diskette.

Now you can put both diskettes away - LETTER has been copied to the second diskette (and has been retired from use for all future examples).

If you want the copied file to have the “same old name” on the other diskette, this is what you would type in Step 4:

copy letter b:

or

copy letter b:letter

For You to Try

Practice this exercise by copying the file BLUE.BAS to another diskette. Change the name, if you wish. Remember, the backup diskette must have been formatted, if it's new.

TYPE - Displaying What Is in a File

The TYPE command lets you “look into” a file; that is, it displays the contents of a file on the screen.

As the example will show, you can also print the contents, if you have a printer.

Before You Begin

Get the diskette that has the file you want to display. You also need to know the exact name of the file (use DIR again).

Here's How You Do It

For this example, assume that the file you want to display is ITEMS.DAT.

- 1.** Make sure DOS is ready for a command; A> is displayed.
- 2.** Insert the diskette with ITEMS.DAT into drive A.
- 3.** If you have a printer:
 - 3A** Make sure the printer is turned on, is online, and has paper.
 - 3B** Press and hold the Ctrl key, then press the Prtsc key.



RENAME - Changing a File's Name

The RENAME command lets you change a file's name, its extension, or both.

This command may be useful if you've found that you simply cannot type a name the way you've spelled it. More often, the reason for changing is that you just want to refer to a file with a different name.

Before You Begin

Get the diskette with the file that you want to rename. You also need to know its exact "old" filename, and its extension, if it has one. (Remember, you can use the DIR command to find out the filename.)

Renaming With One Drive

For this example, let's assume that a diskette has the file STOCKS.DAT on it, but we have decided that ASSETS.80 is a more descriptive name for this information. Also assume that we have checked this diskette's directory and found that the diskette does not already have a file named ASSETS.80 on it.

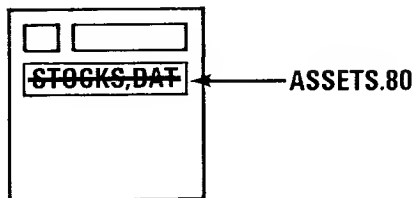

Here's how to change the name:

1. Make sure DOS is ready and **A>** is displayed.
2. Insert the diskette with **STOCKS.DAT** into drive A.
3. Type:

```
rename stocks.dat assets.80
```

Check your typing, and then press Enter.

Notice that the "old" name is first, then a space, then the "new" name.

4. In a moment, DOS displays the prompt, **A>**, and the file has been renamed.
5. You can check to see that the file has really been renamed by typing:

```
dir stocks.dat
```

This should be displayed:

```
File not found
```

```
A> _
```

Then type:

```
dir assets.80
```

Now the information about that file should be displayed.

6. Remove your diskette and put it back in its envelope.

Be careful about using global filename characters in the "old" file specification. You may get unexpected results. Changing back to the names you want may be more tedious than renaming the files one-by-one in the first place.

Renaming With Two Drives

If you have two diskette drives and already have another diskette in drive A, insert the diskette with STOCKS.DAT into drive B, then type B:. Now press Enter.

Then repeating Step 3, type:

```
rename stocks.dat assets.80
```

Now press Enter.

Repeat Step 5:

```
dir stocks.dat
```

```
and
```

```
dir assets.80
```

To switch the default drive back to A, type A:, then press Enter.

An Exercise For You to Try

Try using the RENAME command on one of the files that you copied (in a previous “practice” exercise).

ERASE - Removing a File from a Diskette

One of the “housekeeping” chores associated with diskettes is to remove files that you no longer need. The ERASE command does this for you.

Removing old files from a diskette makes room for new information. It can eliminate a potential source of confusion too - you are less likely to use an old version of a program or an old data file for processing.

But plan ahead and check your typing when you use ERASE.

After a file is erased, the data is gone. Unless you have made a backup, the only way to re-create a file that has been erased is by repeating the steps that you took to create it in the first place.

Before You Begin

You need the diskette with the file that you want to erase. Again, you need to know the exact filename and extension of that file (use DIR if you need to).

And make sure you really will not need this file.

With One Drive

For this example, assume that the file to be removed is ASSETS.80 (the one we just used in the RENAME example).

1. Make sure DOS is ready with A> displayed.
2. Insert the diskette with the file you no longer need into drive A.
3. Type:

```
erase assets.80
```

and check your typing. Now press Enter.

4. In a moment, DOS shows you the prompt, A>. The ASSETS.80 file has been removed from the diskette.
5. To assure that the file has been erased, try the DIR command again, like this:

```
dir assets.80
```

and press Enter.

The message, "File not found" and the DOS prompt, A>, should appear.

6. Remove the diskette and put it back in its envelope.

With Two Drives

If you can use drive B, insert the diskette into drive B and type the following for Step 3:

```
erase b:assets.80
```

and this for Step 5:

```
dir b:assets.80
```

Again, the only difference is that you have to remember to type the drive specifier (b:), because it is not the default drive.

Global Filename Characters

BE CAREFUL WITH GLOBAL FILENAME CHARACTERS.

We recommend that you **DO NOT USE** global filename characters in the file specification of the ERASE command until you know exactly what they will do.

For example, typing

```
erase *.*
```

removes all the files from the diskettes (except the DOS system files, if present).

If the files you remove with global filename characters are not the ones that you expected, you can recover this information only if you have previously made a backup diskette.

MODE - Shifting the Display on the Screen

If you have the Color/Graphics Monitor Adapter, you may find that the first two or three characters on a line of the display do not show up on the screen. If your display device does not have a horizontal adjustment control, you can use the DOS MODE command to shift the displayed lines to the right.

Before You Begin

You need only your DOS diskette to do this.

Shift Right

1. Make sure that DOS is ready and A> is displayed (although you probably can't see it).
2. Type:

```
mode ,r,t
```

Check your typing - did you put the space and then the comma before the "r"?

When it's okay, press the Enter key.

3. Now a test pattern will appear on your screen.

```
0123456789012345678901234567890123456789
```

Do you see the leftmost 0? (Y/N)

4. If your screen looks okay, type this:

y

and press the Enter key.

If you want your screen moved over to the right a little more, type:

n

and press the Enter key.

Note: We've also given you a way to shift the display over using the BASIC OUT command. See the "Using BASIC" chapter in this section.

The *Disk Operating System* book describes more uses of the MODE command.

Helps and Hints

We are ending this chapter with a few hints - maybe they will save you some trouble or help you as you use your IBM Personal Computer.

- Make backups regularly.

(We have repeated this already, but since this is our last chance, we are saying it one more time.)

- Sometimes, commands do not work as you expected because a file specification was typed incorrectly.
 - Check your typing.
 - Do you have the correct diskette in the drive?
 - Check the directory of the diskette.
 - Has the correct diskette drive been specified or is it being assumed? Has the colon been included?
 - Has the filename been spelled correctly?
 - Have you forgotten to use the extension?
(In the case of BASIC program files, for example, it is easy to forget the .BAS that BASIC uses for an extension.)
- If a command still doesn't work, read the book again.
- Be careful with global filename characters, especially in the ERASE command. If you insist on using them:
 - Use the DIR command first with the global filename specification, to test the results.
 - Check to see that these are really the files you want to delete.
 - Then, go ahead.
- Print a directory frequently (if you have a printer) and store the listing with the diskette. The labels are usually too small to hold everything you want to write on them.

- The date and time shown with each directory entry are the date and time of the last addition or change to that file. The date and time are not changed during a COPY or a DISKCOPY.

At first glance,

```
diskcopy a: b:
and copy a:*. * b:
```

may appear to have the same purpose - copying an entire diskette. They do, only when copying to a diskette with no files on it.

With COPY, if files already exist on the backup diskette, they will either be replaced (if files being copied have the same name) or left alone. This is because COPY goes through the original diskette, copying each file, one at a time. COPY does not disturb old files on the backup diskette as long as their names aren't the same as those of the files being copied.

DISKCOPY, however, makes a "carbon copy" of the original diskette, wiping out all old files on the backup diskette during the copy process.

Summary

We've covered a lot in this chapter. We have told you about:

- Starting DOS and telling it the date
- Keys that have special uses in DOS
- Making a backup copy of your DOS diskette
- Diskettes and terms that are used with them
- Files and their names
- Finding out what files are on the DOS diskette.

We have provided step-by-step procedures for using these DOS commands:

- FORMAT
- DIR
- DISKCOPY
- COPY
- TYPE
- RENAME
- ERASE
- MODE

We hope you're well on your way to feeling comfortable with your computer and DOS. No matter how much we've covered, there's always more - in particular, we haven't given you the shortcuts that you'll start to pick up as you read the *Disk Operating System* book and use the commands.

Now it's time to read the next chapter, "Using BASIC," to learn about running BASIC programs.

Notes:

Using BASIC

Contents

Introduction	3-3
Starting BASIC	3-5
For Cassette BASIC	3-5
If Your Computer Is Off	3-5
If Your Computer Is On	3-5
For Disk BASIC	3-6
For Advanced BASIC	3-6
The BASIC Startup Screen	3-7
The BASIC Prompt	3-7
Shifting the Display on the Screen	3-8
Returning to DOS	3-9
Several BASIC Commands	3-9
Some Keys You Will Use With BASIC	3-10
Function Keys	3-10
Running a BASIC Program	3-11
Running the SAMPLES Program	3-12
For Choices A, B, C, H, and I	3-14
For Choices D, E, F, G, and J (and the others too)	3-14
Running the COMM Program	3-16
COMM Program Choices	3-18
Running a BASIC Program on Another Diskette	3-19
With One Diskette Drive	3-20
With Two Diskette Drives	3-21
If You've Forgotten the File's Name	3-21
Entering Your Own BASIC Program	3-23
Storing Your BASIC Program	3-25
Changing Your BASIC Program	3-25
Finding Out What the Statements Are	3-26
Retyping	3-27
The EDIT Command	3-28
Adding a Statement	3-29
Removing a Statement	3-30
Summary	3-31

Notes:

Introduction

Your IBM Personal Computer has three versions of BASIC. Cassette BASIC is built into your computer. Disk BASIC and Advanced BASIC come to you on your DOS diskette.

BASIC is a programming language that is used to write programs - sets of instructions to tell your IBM Personal Computer what it should do for you.

Cassette BASIC uses a cassette recorder to hold program and data files. It cannot use diskettes.

Disk BASIC does everything Cassette BASIC does and, in addition, can use diskettes for files.

Advanced BASIC does everything that Cassette BASIC and Disk BASIC do, and more. It also has some commands like CIRCLE, DRAW, and PAINT that let you do some nifty graphics if you have the Color/Graphics Monitor Adapter. And it has the PLAY statement for making your computer play tunes.

You can find out more about the additional features of all three versions of BASIC in Chapter 1 of the *IBM Personal Computer BASIC* book.

Both Disk BASIC and Advanced BASIC run under DOS, which means that DOS must be running before Disk BASIC or Advanced BASIC (or programs written in Disk BASIC or Advanced BASIC) can be started. They use DOS to manage input from (reading) and output to (writing) the various devices of your computing system.

This section is meant to familiarize you with enough BASIC so that you can use the SAMPLES program (on your DOS diskette) and can run other BASIC programs that you buy. The chapter also shows you how to enter a very small BASIC program of your own.

Starting BASIC

For Cassette BASIC

Remember, Cassette BASIC does not run under DOS or use diskettes.

If Your Computer Is Off

1. If your system has diskette drives, remove any diskette from drive A and shut the drive door.
2. Turn on your computer.
3. The BASIC startup screen is displayed.

If Your Computer Is On

1. If your system has diskette drives, make sure there is no diskette in drive A and that the diskette door is shut.
2. Press and hold the Ctrl and Alt keys, then press the Del key.

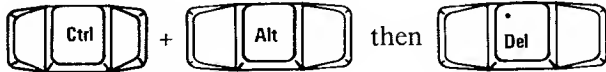

3. The BASIC startup screen appears.

For Disk BASIC

1. Make sure DOS is ready and **A>** is displayed.
2. Insert the DOS diskette into drive A, if it is not already there.
3. Type:

 basic

 and press the Enter key.
4. The BASIC startup screen appears.

For Advanced BASIC

1. Make sure DOS is ready and **A>** is displayed.
2. Insert the DOS diskette into drive A, if it is not already there.
3. Type:

 basica

 and press the Enter key.
4. The BASIC startup screen appears.

You will see that the only difference between starting Disk BASIC and Advanced BASIC is the “a” at the end of the word “basic.”

The BASIC Startup Screen

When BASIC is started, a screen similar to this is displayed:

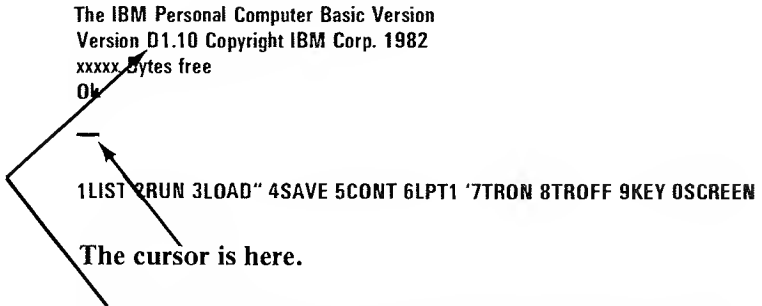

The **D** in this message tells you that **Disk BASIC** has been started. The message may show a **C** for **Cassette BASIC**, or an **A** for **Advanced BASIC**.

Instead of **xxxxx**, you will see a number that tells you how much room you have in the computer's memory for your programs and data.

The BASIC Prompt

Ok is BASIC's prompt. It tells you that BASIC is ready for you to tell it what to do. You need to remember to type **BASIC** commands and statements after **Ok**. You can use **DOS** commands only when you see **A>**; not when you see **Ok**.

Ok also tells you that the keyboard is operating in **BASIC** mode. The "Keyboard Layout and Usage" chapter in the "Operations" section contains a complete description of what the keys do.

Shifting the Display on the Screen

If you have a Color/Graphics Monitor Adapter option, you may find that the first two or three characters on a line of the display do not show up on the screen. If your display device does not have a horizontal adjustment control, you can do the following to shift the display, whether Cassette BASIC, Disk BASIC, or Advanced BASIC is running:

1. When you see BASIC's prompt, **Ok**, type:

out 980,2:	out 981,43 — for a 40-column display
out 980,2:	out 981,85 — for a 80-column display

Check your typing, and correct if necessary. Then press the Enter key.

Note: You can also shift the display from DOS. See the section "MODE - Shifting the Display on the Screen" in the "Using DOS" chapter.

For other information about Cassette BASIC, see the *BASIC* book. The remainder of this section assumes that you are using Disk BASIC or Advanced BASIC.

Returning to DOS

Sometimes you will want to return to DOS after running a BASIC program. For example, you might want to use COPY to make a backup copy of a file that a BASIC program created or to change from Disk BASIC to Advanced BASIC.

To return to DOS from BASIC:

1. Make sure BASIC is ready for a command - **Ok** is displayed.
2. Type:

 system

 and press the Enter key.
3. Now you will see the DOS prompt, **A>**, and you can give DOS a command.

Several BASIC Commands

Some DOS commands have corresponding commands in both Disk BASIC and Advanced BASIC, so you do not always need to return to DOS. These commands are:

DOS Command	BASIC/Advanced BASIC Command
DIR	FILES
ERASE	KILL
RENAME	NAME

Some Keys You Will Use With BASIC

The keys we discussed before in “Some Keys You Will Use With DOS” also work with BASIC (except Ctrl and Prtsc).

Function Keys

You will also find the function keys (the double column of keys on the left side of the keyboard) helpful for entering some BASIC commands you use again and again. When you press a function key, a whole word or phrase is entered, saving you some typing.

Look at the bottom line of the BASIC startup screen. It reminds you of what word the function keys are associated with. For example, if you press F3, it is the same as if you typed:

load

Some of the examples that follow will show how you can use these keys to save typing time.

Look in Chapter 2, “The Keyboard” and Chapter 4, “KEY Statement” in the *BASIC* book for more information about keys used with BASIC.

Running a BASIC Program

Two steps are involved with running a BASIC program that you have on a diskette.

The first step is getting a copy of the program transferred from the diskette to the computer's memory. This is called loading the program and is done (appropriately enough) with a `LOAD` command. \

The second step is the actual performance of the program's instructions - running or executing the program. The command used to do this is `RUN`.

Let's go through this sequence looking at the `SAMPLES` program that is on your DOS diskette.

Running the SAMPLES Program

1. Make sure DOS is ready and **A>** is displayed.
2. Insert the DOS diskette into drive A, if it is not already there.
3. Type:

basic

and press the Enter key.

4. You'll see the BASIC prompt, **Ok**.

Now type this:

load "samples

and press the Enter key.

(Or you can do it with the F3 function key like this:

Press: F3

Type: **samples**

Press: Enter key

Try it this way next time.)

5. When you see **Ok**, type:

run

and press the Enter key.

(Or just press function key F2.)

When this screen appears, press the spacebar.

IBM
Personal Computer



(C) Copyright IBM Corp 1981

Press space bar to continue

6. Now you will see this screen. It is called a menu, because it is like a menu at a restaurant - you select the item you want from a fixed number of choices.

SAMPLE PROGRAMS

A - MUSIC (48K)
B - ART (32K - Color/Graphics)
C - MORTGAGE (48K)
D - CIRCLE (BASICA - Color/Graphics)
E - DONKEY (BASICA - Color/Graphics)
F - PIECHART (BASICA - Color/Graphics)
G - BALL (BASICA - Color/Graphics)
H - COLORBAR (32K)
I - CALENDAR (32K)
J - SPACE (BASICA - Color/Graphics)

ESC KEY - EXIT

ENTER LETTER OF PROGRAM

NOTE: All of the above programs require 48K if
using BASICA

Look at the remarks next to the menu items. These tell you how much computer memory you need, whether you need to use Advanced BASIC (BASICA), and whether you need a Color/Graphics Monitor Adapter.

For Choices A, B, C, H, and I

Try choice H - COLORBAR. Just type:

h

You do not need to press the Enter key. Follow the directions that appear on the screen to see the computer display the different colors (only different shades of grey for black and white displays). Notice that the system prompts you to press the Esc key to exit the program and return to the SAMPLE menu.

You can select I now. You can also run A or C, if your IBM Personal Computer has 48K or more, of memory. Or try B if you have the Color/Graphics Monitor Adapter.

When you have tried any or all of these programs (A, B, C, H, and I), press the Esc key.

Now you will see the BASIC prompt, 0k.

For Choices D, E, F, G, and J (and the others too)

In order to try choices D, E, F, G, and J, you need at least 48K of memory and a Color/Graphics Monitor Adapter. Let's assume that you do and are now looking at the menu.

Do this:

1. Press the Esc (Escape) key.

You don't have to press the Enter key.

This returns you to Disk BASIC and you will see the BASIC prompt, 0k.

2. Make sure your DOS diskette is still in drive A.
Then to return to DOS, type:

`system`

and press the Enter key.

This gets you out of Disk BASIC and back to DOS.
Now we want to start SAMPLES, again using
Advanced BASIC (instead of Disk BASIC).

3. When you see the DOS prompt, `A>`, type:

`basica`

and press the Enter key.

4. When you see the BASIC prompt, `0k`, type:

`load "samples`

and press the Enter key.

5. When you see `0k` again, type:

`run`

and press the Enter key.

6. The SAMPLES program menu will be displayed
again.

Now you can select any item on the menu because
you are now in Advanced BASIC and should have
the correct computer system.

Just type the letter of your choice and have fun.

Note: If you have the Color/Graphics Monitor
Adapter and enough memory, you can run
the SAMPLES program from now on by
just starting at Step 3.

Running the COMM Program

A sample telecommunications program is also provided on the DOS diskette. This program lets you establish an asynchronous communications link between your IBM Personal Computer and another IBM Personal Computer, an IBM Series/1 computer, or two communications network services.

This means that your computer can “talk” to another computer or be part of a network service. You can imagine that the computers are talking on the telephone to each other. (Using a network service is like being on a “party line.”)

The COMM program will work “as is” if you have the necessary option (Asynchronous Communications Adapter), equipment, and subscriptions. (For a description of the adapter you need, see “Asynchronous Communications Adapter” in Section 5 of this binder.) For assistance with interfacing to external devices, consult your dealer.

You could also use this sample program as the model for writing your own telecommunications program.

Let's look at the COMM program menu - you can do this even if you do not plan to communicate with another computer. Do this:

1. Make sure Disk BASIC or Advanced BASIC is running and **Ok** is displayed.
2. Insert the DOS diskette into drive A.
3. Type:

load "comm

and press the Enter key.

4. Type:

run

and press the Enter key.

5. The sample communications program menu now appears:

COMMUNICATIONS MENU

Choose one of the following:

- 1 Description of program
- 2 Dow Jones/News Retrieval
- 3 IBM Personal Computer
- 4 Series/1
- 5 THE SOURCE
- 6 Other service
- 7 End program

Choice —

 **Blinking cursor**

6. You can pick item 1 or 7 now, even if you're not ready to establish communications.

You must have the asynchronous communications adapter and the proper cabling to pick any of the other choices.

Type the number of your choice and press the Enter key.

7. Each choice (except 7) will show you another menu.

When you're through reading the information, press function key 1. (Function key 1 is the key in the upper left corner of the keyboard.)

Now the main menu appears again.

8. Type:

7

and press the Enter key.

You are back to BASIC again, and 0k is displayed.

COMM Program Choices

Here's a short description of the COMM program choices:

1 Description of program

Displays a screen that describes the COMM program.

2 Dow Jones/News Retrieval

Lets you dial in to the Dow Jones/News service.

You must have a Dow Jones/News service subscription, as well as the communications equipment, to run this choice.

3 IBM Personal Computer

Lets your IBM Personal Computer "talk to" another IBM Personal Computer.

You must have the asynchronous communications adapter and other purchased equipment to run this choice.

4 Series/1

Lets your IBM Personal Computer communicate with an IBM Series/1 computer, running either Real Time Programming System V5.1 or Event Driven Executive V3.0.

5 THE SOURCE

Lets you connect to THE SOURCE service.

You need a subscription to THE SOURCE and the adapter and purchased equipment to run this choice.

6 Other service

Lets you describe the kind of communications your IBM Personal Computer will set up. You do this if the choices that were made in the COMM program are not correct for your case. Then you can start the communications session using the characteristics you've described.

7 End program

Lets you end the COMM program and go back to BASIC. You will then see the BASIC prompt, Ok.

Running a BASIC Program on Another Diskette

For this example, let's assume that the BASIC program you want to run is called BOWLING, and it's not on your DOS diskette.

Let's assume too, that BOWLING is a Disk BASIC program (that is, it doesn't use the extended features of Advanced BASIC).

With One Diskette Drive

1. When you see the DOS prompt, **A>**, start Disk BASIC by typing:

basic

and press the Enter key.

2. The BASIC prompt, **Ok**, appears.

Remove your DOS diskette from drive A.

3. Insert the diskette with the file **BOWLING** into drive A.

4. Now type:

load "bowling

and press the Enter key.

Note: If you do not supply an extension in the command, BASIC will look for a file with the extension **.BAS** (BAS stands for BASIC). In this case, BASIC will look for a file named **BOWLING.BAS**.

5. When the BASIC prompt, **Ok**, appears again, type this:

run

and press Enter.

6. Now the program **BOWLING** does whatever it's supposed to do.

With Two Diskette Drives

If you have another diskette drive, you could insert the diskette with BOWLING into the other drive.

Then in Step 4, you would type:

```
load "b:bowling
```

Notice that you have to specify the drive - where the diskette with the program is.

If You've Forgotten the File's Name

Sometimes you may get a message that says:

```
File not found
```

after you've typed a command. It may be caused by spelling the filename incorrectly, among other reasons.

BASIC has a command, FILES, that works like the DOS DIR command. It lets you list what is on a diskette. Then you can check to see that the correct diskette is in the drive and that the name was spelled correctly. You do not have to return to DOS and then come back to BASIC. Following the BASIC prompt, **Ok**, just type:

```
files
```

and press the Enter key to see the name of all the files on the default drive.

If you type:

```
files "b:*.bas
```

all the files on the diskette in drive B that have .BAS as their extension would be displayed.

This might be the result of such a command if the DOS diskette were in drive B.

Ok

files "b:*.bas

ART	.BAS	SAMPLES	.BAS	MORTGAGE	.BAS
COLORBAR	.BAS	CALENDAR	.BAS	MUSIC	.BAS
DONKEY	.BAS	CIRCLE	.BAS	PIECHART	.BAS
SPACE	.BAS	BALL	.BAS	COMM	.BAS

Ok

Entering Your Own BASIC Program

A BASIC program consists of one or more BASIC statements that are preceded by line numbers. The line numbers are used by BASIC to control the sequence in which the statements are run. You use the line numbers to change, add, or delete lines within a program.

You tell BASIC that you are entering a program by beginning the line you type with a line number. After the line number comes a BASIC statement.

Unlike entering a command, the statement is not run when you press the Enter key. A program is not run until you type a RUN command.

Let's look at an example - a very simple program that just displays the numbers 1, 2, and 3.

1. Make sure BASIC is ready - 0k is displayed.

2. Type:

```
new
```

and press the Enter key.

3. Type:

```
10 print 1
```

and press the Enter key.

4. Type:

```
20 print 2
```

and press Enter.

5. Type:

```
30 print 3
```

and press Enter.

6. Now you are finished entering this short program. Your screen should look like this:

```
Ok  
new  
Ok  
10 print 1  
20 print 2  
30 print 3
```



The cursor is here.

7. To see what this program does, type:

```
run
```

and press the Enter key.

8. If the typing is correct, it works. Now your screen should look like this:

```
Ok  
new  
Ok  
10 print 1  
20 print 2  
30 print 3  
run  
1  
2  
3  
Ok
```

This example shows the use of line numbers that increase by 10. This leaves room for inserting new statements, as you will see later. Actually, you could use any line numbers as long as they were in increasing order.

Storing Your BASIC Program

Before we start making changes to this program, let's store it on a diskette. Right now, while it is the current program (that is, the one in memory), every time you type RUN, the program will be executed. If you want to be able to run this program after you load and run some other programs, however, you must have it stored on a diskette.

Let's assume we want to call this program ORIG123 (which stands for "Original 123"). Here is how you save it:

1. Make sure Disk BASIC or Advanced BASIC is ready - **Ok** is displayed.
2. Insert a diskette into drive A. (The diskette should have been formatted and have space on it.)

3. Type:

```
save "orig123
```

and press Enter.

4. The program is stored on the diskette in drive A with the filename ORIG123 and the extension .BAS. BASIC assigns that extension because we did not specify one.

Now you can load ORIG123 and RUN it just as we showed you with the BOWLING program (see "Running a BASIC Program on Another Diskette").

Changing Your BASIC Program

To change a program, we first need to know what the statements in the program are; knowing that, we can make changes to particular statements, as necessary.

Finding Out What the Statements Are

BASIC's LIST command displays the statements in the BASIC program that is currently loaded.

Let's use our ORIG123 file to demonstrate. Assume for this example that drive A is the default drive.

1. Make sure Disk BASIC or Advanced BASIC is ready - Ok is displayed.
2. Insert the diskette with ORIG123 on it into drive A.
3. Type:

```
load "orig123
```

and press the Enter key.

4. The program in the file ORIG123.BAS is loaded from the diskette, then the BASIC prompt, Ok, is displayed.
5. Type:

```
list
```

and press the Enter key.

Program statements are listed on the screen. For our example, it should look like this:

```
Ok  
load "orig123  
Ok  
list  
10 PRINT 1  
20 PRINT 2  
30 PRINT 3  
Ok
```

Assume that we wanted the numbers to be printed on one line, instead of on three. A semicolon (;) added to the end of both lines 10 and 20 would make the program do this.

We'll show you two different ways of making these changes - retyping and the Edit command.

Retyping

If you type a BASIC statement that has the same line number as a line in the program in memory, that line is replaced with the new line as soon as you press the Enter key.

For example, to change line 10, type the following after the BASIC prompt, **Ok**:

10 print 1; ←————— **Note that there's now a semicolon at the end of the line.**

and press the Enter key.

Now list the program (type **list** and press Enter). Verify that the original line has been replaced by the one with the semicolon.

(If you want, you can also type **run** and see what the program does now.)

The retyping method is most useful when the statement needs a lot of changing.

The EDIT Command

The second method uses BASIC's EDIT Command.

Remember that line 20 in the program still needs a semicolon, so let's make the change like this:

1. After the BASIC prompt, **Ok**, type:

```
edit 20
```

and press the Enter key.

2. Line 20 will be shown to you like this:

```
20 PRINT 2
```

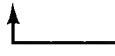
 The cursor is here.

3. Using the Cursor Right key.



(on the numeric keypad),

move the cursor to the position after the second 2.
Now type the semicolon



and press the Enter key.

This method is useful when most of the statement is correct.

Editing and the use of the cursor control keys are explained in Chapter 2, "The BASIC Program Editor" in the *BASIC* manual.

Now LIST and RUN the program. Does your program look like this?

```
Ok
list
10 PRINT 1;
20 PRINT 2;
30 PRINT 3
Ok
run
  1  2  3
Ok
```

If it doesn't, use the EDIT command to make your screen match this one and run the program again.

Adding a Statement

You can add a statement to a program by typing the statement with a new line number.

For example, since our program uses only line numbers 10, 20, and 30, we could insert a statement between 10 and 20 by choosing any number between them - like this:

```
12 print 4;
```

We can also add lines to the end of a program by typing statements with line numbers greater than the last line number used. (The line number has to be less than 65529, however.)

In our example, we could add a line to the end like this:

```
155 print 1+4+2+3
```

Go ahead - try it.

Removing a Statement

To delete a line from a program, type only the line number and then press the Enter key.

For example, to delete the statement that we just added to print 4, type:

12

and then press the Enter key.

Note: Remember the discussion of the Esc key in the “Using DOS” chapter? Well, don’t use the Esc key to try to delete a program line. The Esc key just erases the currently displayed line from the screen. It does not change the original line in the program; the original line will still remain in the program.

Summary

These sections on BASIC have told you about:

- Starting BASIC on your IBM Personal Computer.
- Returning to DOS.
- Loading and running the SAMPLES program that is provided on the DOS diskette.
- Loading and running the COMM program on the DOS diskette.
- Loading and running other BASIC programs.
- Finding out what files are on a diskette with the FILES command.
- Entering, saving, running, listing, and editing a program of your own.

As you become more familiar with running the BASIC programs you acquire, or if you want to start writing your own programs in BASIC, use the *IBM Personal Computer BASIC* book. In it you will find alternative methods and much more detailed information than what we've given you here.

We hope this chapter has helped you to start using your computer quickly. So start up the SAMPLES program and go!

Notes:

SECTION 4. PROBLEM DETERMINATION PROCEDURES

Contents

Introduction	4-3
Checking Electrical Connections	4-5
Power-On Self Test	4-8
Error Examples	4-11
Diagnostic Testing	4-15
IBM Printer Problem Determination Procedures	4-66
IBM Color Display Problem Determination Procedures	4-69

Notes:

Introduction

The Problem Determination Procedures help you to solve operational or system failures. By following the step-by-step procedures and answering yes or no to the questions asked, you will be able to determine what you must do to make your system operational again. Once you have determined which unit of your IBM Personal Computer has a problem, have the failing unit serviced.

As part of your problem determination, you may have to load the Diagnostics diskette (the diskette is at the back of this manual). The Diagnostics diskette has a series of tests to help you find a problem in any of the five units of your IBM Personal Computer. These five units are the system unit, expansion unit, keyboard, display, and printer.

For any problem start on the following page with "Checking Electrical Connections."

Notes:

Checking Electrical Connections

1. Set the Power switch of the system unit (and expansion unit, if attached) to Off.
2. Power Off all externally attached devices (printer, TV, etc.).
3. Disconnect all non-IBM devices, except the display.
4. Unplug the system unit's (and expansion unit's) power cord from the wall outlet.

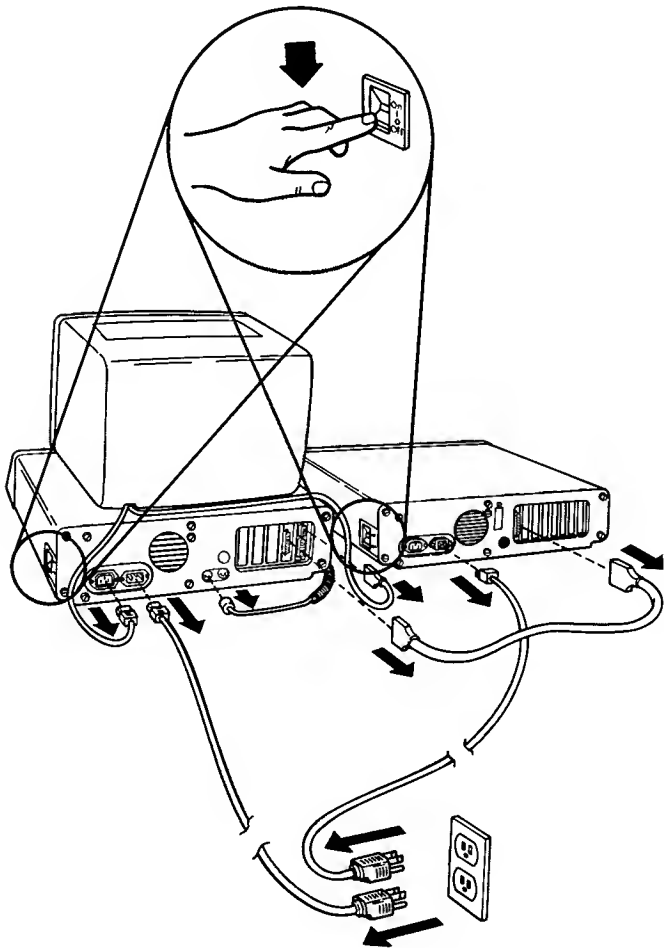

5. Check the wall outlet by plugging in a working lamp.
6. Disconnect and reconnect each cable on the system unit and the expansion unit (if attached) to ensure proper electrical connection.

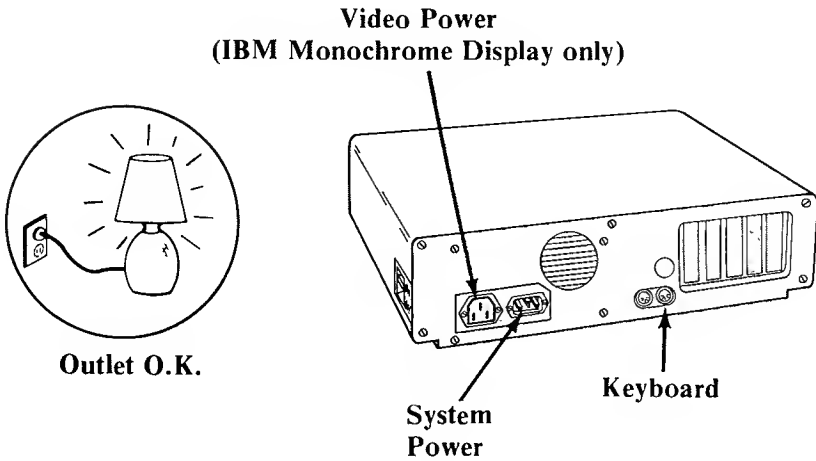

7. If you do not have any IBM Communications Adapter Cables attached to your Personal Computer, go to "Power-On Self Test" on the following page.
8. If you have an IBM Communications Adapter Cable, it came with a wrap plug. Disconnect the Communications Adapter Cable at the modem end (refer to the Communications Adapter Option Installation instructions for cable removal).
9. Refer to the figure below and install the wrap plug (IBM number 8529280) on the modem end of the cable (end furthest from the IBM Personal Computer).

Proceed with "Power-On Self Test" on following page.

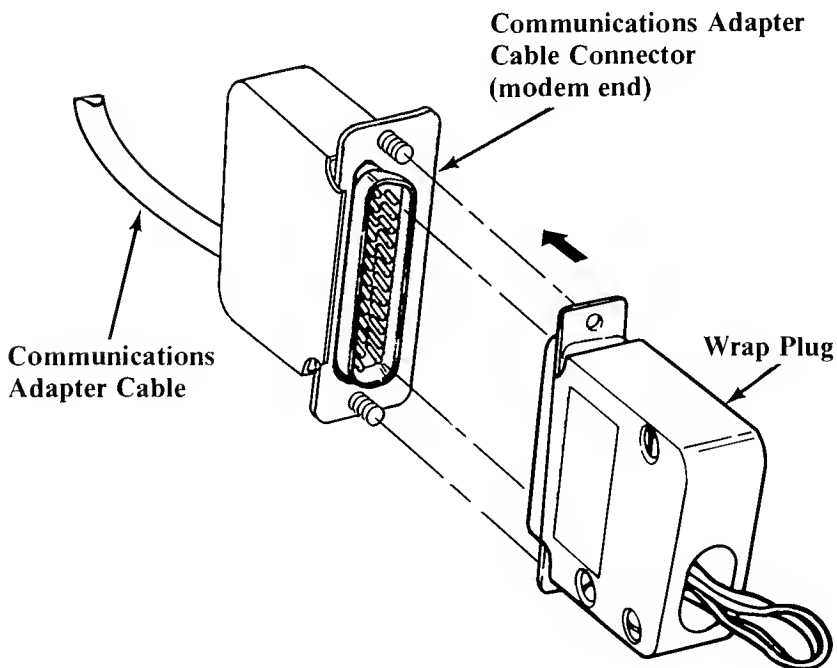

Power-On Self Test

1. Turn Brightness and Contrast knobs fully clockwise.

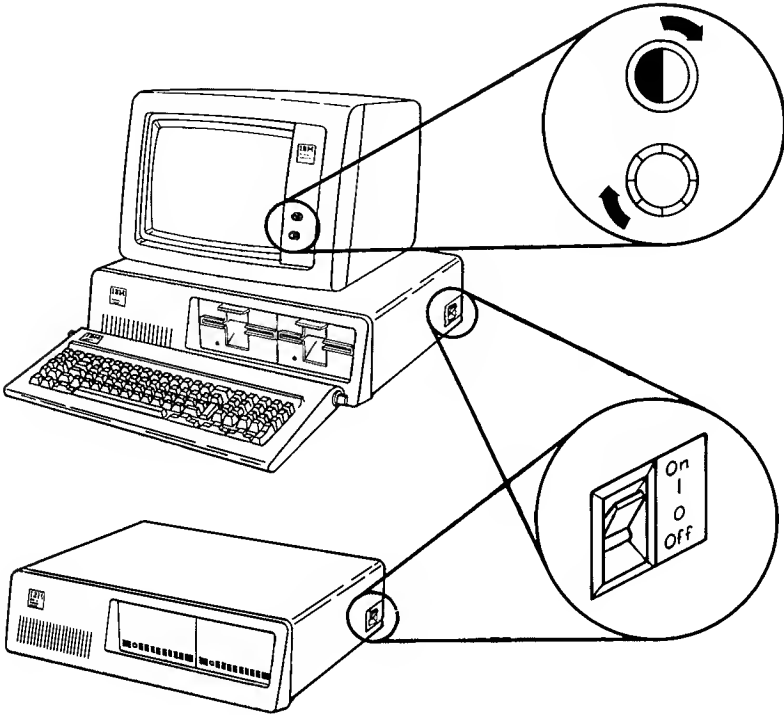

2. Power on all externally attached devices (printer, TV, etc.).
3. If an expansion unit is attached, set the Power switch to On.
4. Set the system unit Power switch to On.

POST will complete in 3 to 90 seconds, depending on the amount of memory installed in your system.

One short beep will be heard when the test is complete.

1

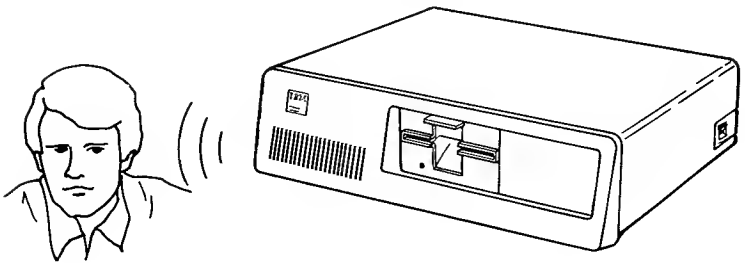

The "IBM Personal Computer BASIC" message will appear. (If, at the end of POST, a diskette or an operating system from the fixed disk drive is automatically loaded, the initial screen from the diskette or the operating system will appear).

2

```
The IBM Personal Computer Basic  
Version X.XX Copyright IBM Corp. XXXX  
XXXXXX Bytes Free  
OK
```

```
1LIST 2RUN 3LOAD" 4SAVE 5CONT 6LPT1 '7TRON 8TROFF 9KEY 0SCREEN
```

3

A blinking cursor will appear.

Did all three of the above occur?

YES - Go to "Diagnostic Testing."

NO - Go to "Error Examples."

Error Examples

Find the incorrect response in the following examples, then follow the instructions in the box marked "Action."

WARNING: If you are having the expansion unit serviced, it is recommended that you back-up all files on the fixed disk drive onto diskettes. Normal shipping and handling can result in permanent loss of data on your fixed disk drives. Depending on the amount of data stored, you may require approximately 64 diskettes to back-up each fixed disk drive. Refer to the IBM Disk Operating System for a description of the BACKUP Command.

Example 1

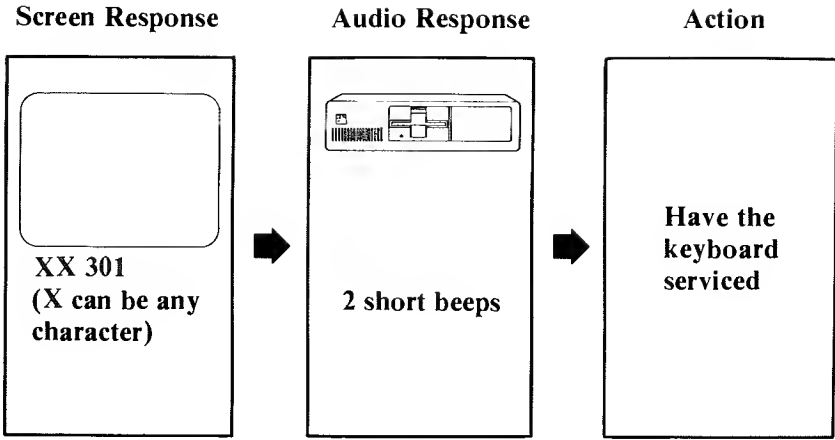

Example 2

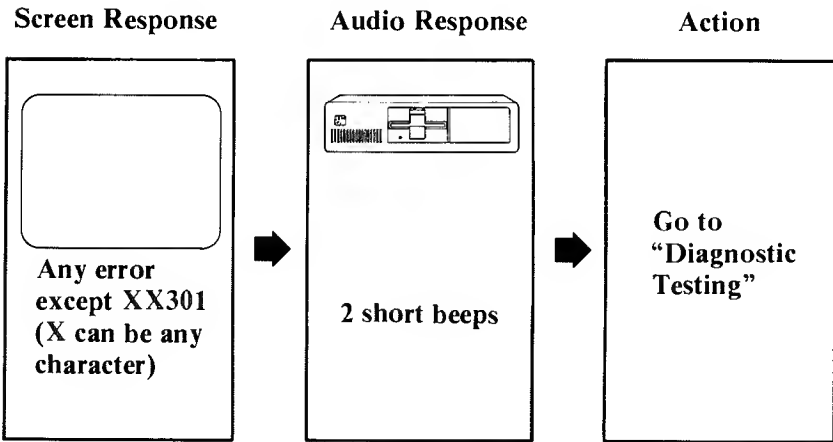

Example 3

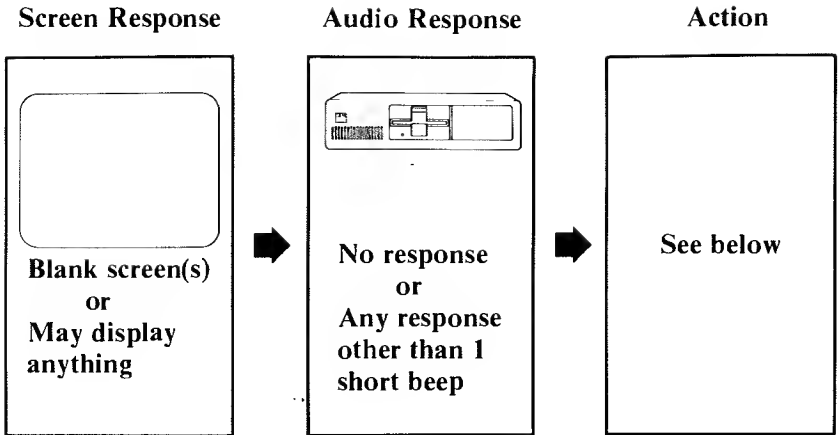

Do you have an expansion unit attached?

NO - Have the system unit serviced.

- YES** -
- Set the system unit and expansion unit Power switches to Off.
 - Set all external power switches Off (printer, TV, etc.).
 - Disconnect the expansion unit cable from the system unit.
 - Set the system unit Power switch to On.

If the error is the same, have the system unit serviced. If the error changes, have the expansion unit and expansion unit cable serviced.

Example 4 Color Display only

Screen Response

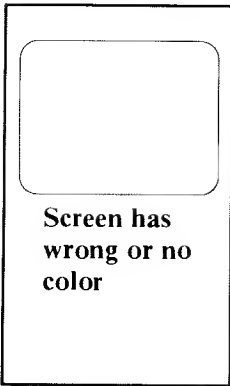

Audio Response

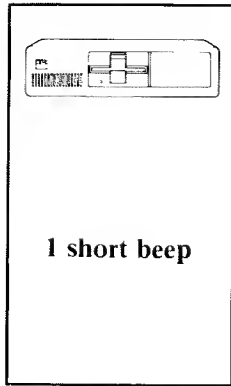

Action

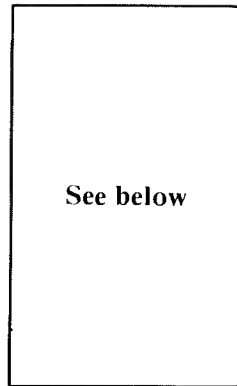

If you are using a TV as your display, verify that the color is correct by disconnecting your TV from the unit. Operate your TV normally to verify color quality. If you have an IBM Color Display, go to "IBM Color Display Problem Determination Procedures."

Example 5

Screen Response

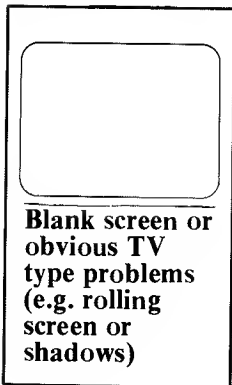

Audio Response

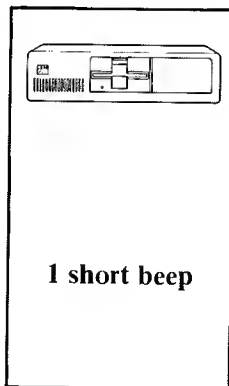

Action

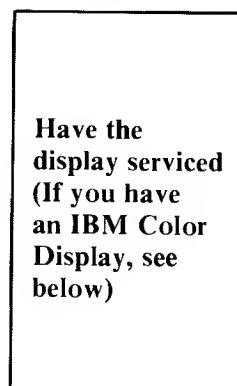

If you have an IBM Color Display, go to "IBM Color Display Problem Determination Procedures."

Diagnostic Testing

During the diagnostic tests, you may be asked to record an error message. This information is needed to aid you in getting your system serviced.

The following are examples of the error messages you may receive, and the probable reasons for the messages. A message ending in 00 means that the test has completed successfully.

Example 1.

XX:XX:XX
ERROR - SYSTEM UNIT XXXX

(X can be any character)

Have the system unit serviced.

Example 2.

XX:XX:XX
ERROR - EXPANSION UNIT XXXX

(X can be any character)

Have the expansion unit serviced.

1. Get the Diagnostics diskette from the back of this manual.

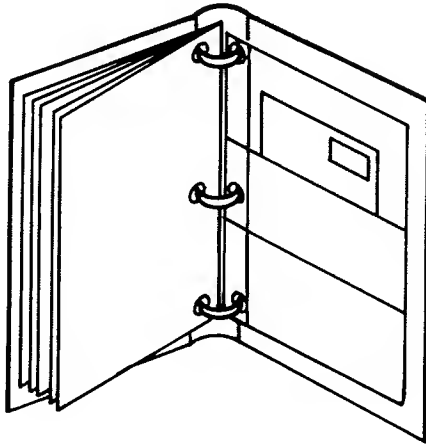

2. Set the Power switch on the system unit (and expansion unit, if attached) to Off.
3. Set all external power switches Off (printer, TV, etc.).
4. Raise the load lever.
5. Insert the Diagnostics diskette into drive A.
6. Push the load lever down.
7. Power on all externally attached devices (printer, TV, etc.).
8. If an expansion unit is attached, set the Power switch to On.
9. Set the system unit Power switch to On.

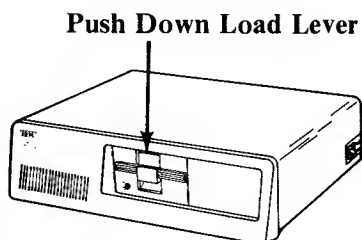
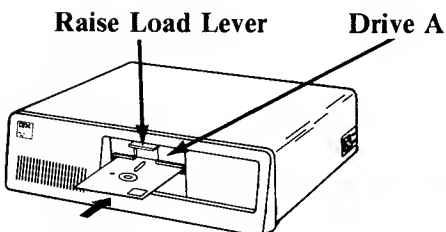

10. Did the following appear on your screen?

The IBM Personal Computer **DIAGNOSTICS**
Version XXX (C) Copyright IBM Corp XXXX
SELECT AN OPTION
0 - RUN DIAGNOSTIC ROUTINES
1 - FORMAT DISKETTE
2 - COPY DISKETTE
3 - PREPARE FIXED DISK FOR RELOCATION
9 - EXIT TO SYSTEM DISKETTE
ENTER THE ACTION DESIRED

YES - Go to Step 11.

NO - Remove the diskette and verify that it:

- Was the Diagnostics diskette.
- Was inserted correctly.

Correct any mistakes. If the Diagnostics diskette was inserted correctly, the system unit is probably at fault.

Note: If you are using your home television or non-IBM display, you could experience data errors while using your diskette drive. This interference is easily corrected by moving your television or display 12 inches away from your IBM Personal Computer.

11. Press  to select **FORMAT DISKETTE** then

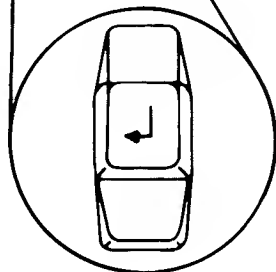
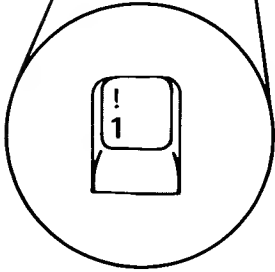
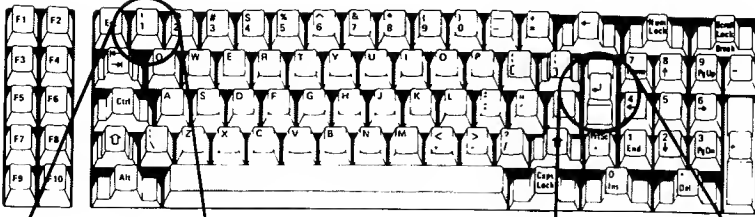

12. Did the following appear on your screen?



The IBM Personal Computer DIAGNOSTICS
Version XXX (C) Copyright IBM Corp XXXX
SELECT AN OPTION
0 - RUN DIAGNOSTIC ROUTINES
1 - FORMAT DISKETTE
2 - COPY DISKETTE
3 - PREPARE FIXED DISK FOR RELOCATION
9 - EXIT TO SYSTEM DISKETTE
ENTER THE ACTION DESIRED
? 1
WHICH DRIVE CONTAINS DISKETTE
TO BE FORMATTED?

YES - Go to Step 13.

NO - Have your keyboard serviced.

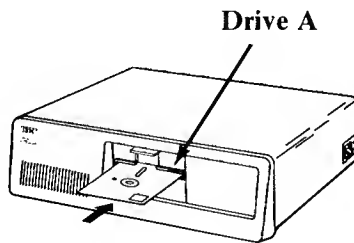
13. Remove the Diagnostics diskette from drive A and insert a blank diskette.



14. Press  then  .

The blank diskette will be formatted, and the in-use light will be on during formatting.

When the in-use light goes out, remove the formatted (scratch) diskette.

Note: A formatted diskette that has no data stored on it is called a *scratch* diskette.

15. Reinsert the Diagnostics diskette into drive A.

Did the following appear on your screen?

SELECT AN OPTION

0 - RUN DIAGNDSTIC RDUTINES



1 - FDRMAT DISKETTE

2 - CDPY DISKETTE

3 - PREPARE FIXED DISK FOR RELDCAIDN

9 - EXIT TD SYSTEM DISKETTE

ENTER THE ACTIDN DESIRED

YES - Press  then .

If you have one display option installed in your system go to Step 17. If you have an IBM Monochrome Display and Printer Adapter and a Color/Graphics Monitor Adapter installed in your system, go to Step 16.

NO - Remove the diskette and verify the following:



- It was a blank diskette.
- The diskettes were inserted in the correct order (blank diskette then Diagnostics diskette).

Try another blank diskette. If the problem still exists, have the system unit serviced.





16. Do you have a display attached to each display adapter installed in your system?

IS A MONITOR ATTACHED TO EVERY DISPLAY ADAPTER (Y/N)?

YES - Press  then  and go to Step 17.

NO - Press  then  and go to Step 17.

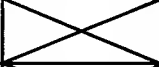
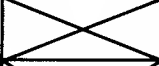
- 17.** Complete the list of installed devices and options and indicate their location with a check mark. Enter the amount of memory installed in your system.

System Unit	Expansion Unit	Installed Device/Option
		System Board
		Expansion Option
		XXX K of Memory
		Keyboard
		Monochrome and Printer Adapter
		X Diskette Drive(s) and Adapter
		Printer Adapter
		Async Communications Adapter
		Matrix Printer
		X Fixed Disk Drive(s) and Adapter
		Game Control Adapter
		Color/Graphics Monitor Adapter
		SDLC Adapter

Installed Devices, Options, and Memory

Note: The IBM Communications Adapter Cable and Printer Adapter Cable will not appear on the list.



In the following sample "S" means the device is installed in the system unit, and "E" means the expansion unit.

- 18.** Does your screen correctly list all your installed devices and options.

THE INSTALLED DEVICES ARE

S SYSTEM BOARD
S EXPANSION OPTION
S 256KB MEMORY
S KEYBOARD
S MONOCHROME & PRINTER ADAPTER
S COLOR/GRAPHICS MONITOR ADAPTER
S 2 DISKETTE DRIVE(S) AND ADAPTER
S GAME CONTROL ADAPTER
E 1 FIXED DISK DRIVE(S) & ADAPTER
S MATRIX PRINTER

IS THE LIST CORRECT (Y/N) ?

YES - Press  then  and go to Step 19.

NO - If the matrix printer was not listed, go to "Printer Problem Determination Procedures." For all other devices or options incorrectly listed, if the option is installed in the system unit, have the system unit serviced. If the option is installed in the expansion unit, have the expansion unit serviced.

19. Press  to select **RUN TESTS ONE TIME**, then



SYSTEM CHECKOUT

0 - RUN TESTS ONE TIME

1 - RUN TESTS MULTIPLE TIMES

2 - LOG UTILITIES

9 - EXIT DIAGNOSTIC ROUTINES

ENTER THE ACTION DESIRED

?

Is an expansion unit attached?

YES - Go to Step 20.

NO - Go to Step 27.

20. Did you receive an expansion unit error message (18XX)?

SYSTEM CHECKOUT

- 0 - RUN TESTS ONE TIME**
- 1 - RUN TEST MULTIPLE TIMES**
- 2 - LOG UTILITIES**
- 9 - EXIT DIAGNOSTIC ROUTINES**

ENTER THE ACTION DESIRED

? 0

SYSTEM UNIT 100

EXPANSION UNIT 1800

THIS TEST TAKES UP TO TWO MINUTES

PLEASE STAND BY

YES - Go to Step 21.

NO - Go to Step 27.

- 21.** Did you receive an 1819 error message (see the following)?

```
SYSTEM UNIT      100
  XX:XX:XX
  ERROR EXPANSION UNIT      1819
PRESS ENTER TO CONTINUE
```

YES - Have the expansion unit serviced.

NO - Go to Step 22.

22. Did you receive an 1820 or 1821 error message?

SYSTEM UNIT 100

XX:XX:XX

ERROR EXPANSION UNIT 182X

PRESS ENTER TO CONTINUE

?

YES - Have the expansion unit and expansion unit cable serviced.

- NO** - a. Set the Power switches on the system unit and expansion unit to Off.
b. Set all external power switches Off (printer, TV, etc.).
c. Disconnect the expansion unit cable from the system unit.
d. Set the system unit's Power switch to On.
e. Go to Step 23.

23. Press  to select **RUN DIAGNOSTIC ROUTINES**,

then  .

**THE IBM PERSONAL COMPUTER DIAGNOSTICS
VERSION XXX (C) COPYRIGHT IBM CORP XXXX**

SELECT AN OPTION

0 - RUN DIAGNOSTIC ROUTINES

1 - FORMAT DISKETTE

2 - COPY DISKETTE

3 - PREPARE FIXED DISK FOR RELOCATION

9 - EXIT TO SYSTEM DISKETTE

ENTER THE ACTION DESIRED

If you have one display option installed in your system, go to Step 25. If you have an IBM Monochrome Display and Printer Adapter and a Color/Graphics Monitor Adapter installed in your system, go to Step 24.

24. Do you have a display attached to each display adapter installed in your system?

IS A MONITOR ATTACHED TO EVERY DISPLAY ADAPTER (Y/N)?

YES - Press  then  and go to Step 25.

NO - Press  then  and go to Step 25.

- 25.** Are any of the options or devices installed in your expansion unit missing from the list?

THE INSTALLED DEVICES ARE

- S SYSTEM BOARD
- S EXPANSION OPTION
- S 256KB MEMORY
- S KEYBOARD
- S MONOCHROME & PRINTER ADAPTER
- S COLOR/GRAPHICS MONITOR ADAPTER
- S 2 DISKETTE DRIVE(S) AND ADAPTER
- S GAME CONTROL ADAPTER
- E 1 FIXED DISK DRIVE(S) & ADAPTER
- S MATRIX PRINTER

IS THE LIST CORRECT (Y/N) ?

YES - Press  then  and go to Step 26.

NO - Have the system unit serviced.

26. Press  to select **RUN TESTS ONE TIME** then



SYSTEM CHECKOUT

0 - RUN TESTS ONE TIME

1 - RUN TESTS MULTIPLE TIMES

2 - LOG UTILITIES

9 - EXIT DIAGNOSTIC ROUTINES

ENTER THE ACTION DESIRED

?

Did you get an 1820 error message?

YES - Have the expansion unit and expansion unit cable serviced.

NO - Have the system unit serviced.

27. Did the following appear on your screen?

**SYSTEM UNIT 100
THIS TEST TAKES UP TO TWO MINUTES
PLEASE STAND BY**



YES - Go to Step 28.

NO - Have the system unit serviced.

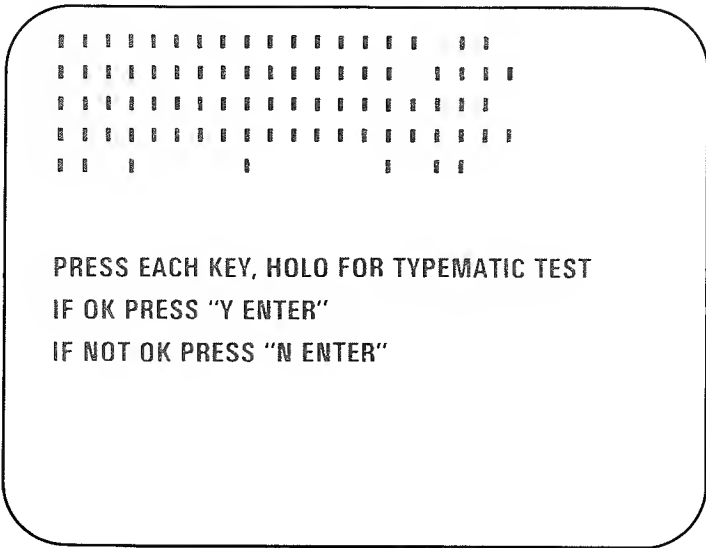
28. Did the following appear on your screen?



YES - Press each key once, then go to Step 29.

NO - Press  then  . Record the error message. Have the system unit serviced.



29. Did the following appear on your screen?



```
1 2 < 1 2 3 4 5 6 7 8 9 0 - = ↔ N S
3 4 L Q W E R T Y U I O P [ ] 7 8 9
5 6 C A S D F G H J K L ; ' ' R 4 5 6
7 8 S \ Z X C V B N M , . / S * 1 2 3 +
9 0 A S C 0 .
```

**PRESS EACH KEY HOLD FOR TYPEMATIC TEST
IF OK PRESS "Y ENTER"
IF NOT OK PRESS "N ENTER"**

YES - Press and hold any key. The corresponding character on the screen will flash. This is the typematic test.

If the typematic test works correctly, press

 then  and go to Step 30. If the

typematic test failed, press  then .

Record the error message. Have the keyboard serviced.

NO - If any block did not change to a character, have the keyboard serviced.

30. Do you have an IBM Monochrome Display attached to your system?

NO - Go to Step 33.

YES - Did the following appear on your screen?

DISPLAY ATTRIBUTES

THIS LINE IS AT NORMAL INTENSITY.

THIS LINE IS INTENSIFIED.

THIS LINE IS IN REVERSE VIDEO.

THIS LINE IS BLINKING

THIS LINE IS UNDERLINED

IS THE SCREEN CORRECT? (Y/N)

YES - Press  then  and go to Step 31.

NO - Press  then  . Record the error message.

If the following error message appears, the system unit is at fault. Have the system unit serviced.

XX:XX:XX

ERROR - SYSTEM UNIT XXXX

(X can be any character)

If the following error message appears, the expansion unit is at fault. Have the expansion unit serviced.

XX:XX:XX

ERROR - EXPANSION UNIT XXXX

(X can be any character)

31. Did the following appear on your screen?

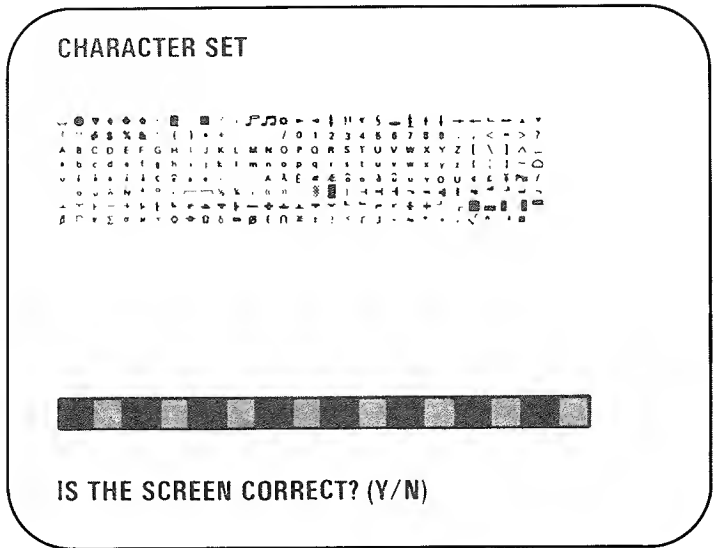

YES - Press  then  and go to Step 32.

NO - Press  then  . Record the error message.

If the following error message appears, the system unit is at fault. Have the system unit serviced.

XX:XX:XX
ERROR - SYSTEM UNIT XXXX
(X can be any character)

If the following error message appears, the expansion unit is at fault. Have the expansion unit serviced.

XX:XX:XX
ERROR - EXPANSION UNIT XXXX
(X can be any character)



32. Did the following appear on your screen?

Printer Problem Determination Procedures
4-38

IS THE SCREEN CORRECT ? (Y/N)

YES - Do you have a Color/Graphics Monitor Adapter installed in your system with a display attached to it?

NO - Press  then  and go to Step 43.

YES - Press  then  and go to Step 33.

NO - Press  then  . Record the error message.

If the error message is 432, go to "Printer Problem Determination Procedures."

If the following error message appears, the system unit is at fault. Have the system unit serviced.

XX:XX:XX
ERROR - SYSTEM UNIT XXXX
(X can be any character)

If the following error message appears, the expansion unit is at fault. Have the expansion unit serviced.

XX:XX:XX
ERROR - EXPANSION UNIT XXXX
(X can be any character)

33. Did the following appear on your color display?

DISPLAY ATTRIBUTES

THIS LINE IS AT NORMAL INTENSITY.

THIS LINE IS INTENSIFIED.

THIS LINE IS IN REVERSE VIDEO.

THIS LINE IS BLINKING.

 BLUE

 GREEN

 CYAN

 RED

 MAGENTA

YELLOW

 WHITE

IS THE SCREEN CORRECT ? (Y/N)

YES - Press  then  and go to Step 34.

NO - Press  then  . Record the error message.

If the following error message appears, the system unit is at fault. Have the system unit serviced.





XX:XX:XX
ERROR - SYSTEM UNIT XXXX
(X can be any character)

If the following error message appears, the expansion unit is at fault. Have the expansion unit serviced.

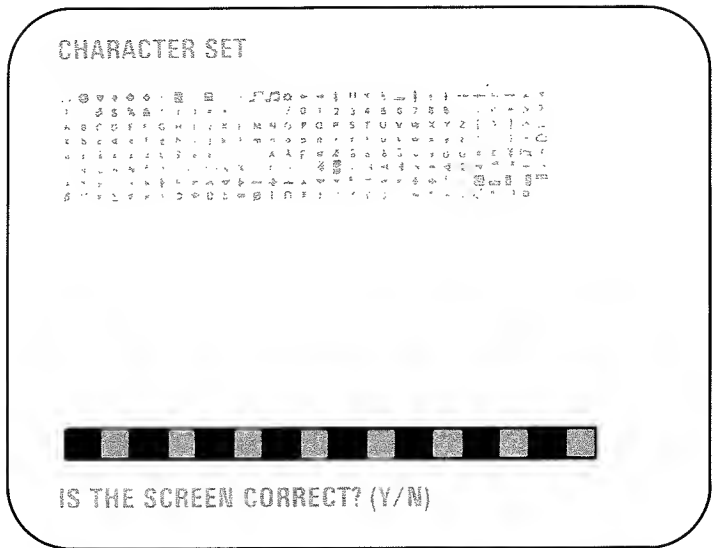
XX:XX:XX
ERROR - EXPANSION UNIT XXXX
(X can be any character)

34. Did the following appear on your screen?



- YES** - Press  then  and go to Step 35.
- NO** - Press  then  . Record the error message.

If the following error message appears, the system unit is at fault. Have the system unit serviced.

XX:XX:XX
ERROR - SYSTEM UNIT XXXX
(X can be any character)

If the following error message appears, the expansion unit is at fault. Have the expansion unit serviced.

XX:XX:XX
ERROR - EXPANSION UNIT XXXX
(X can be any character)

35. Did the following appear on your screen?

80X25 DISPLAY



IS THE SCREEN CORRECT? (Y/N)

YES - Press



then



and go to Step 36.

NO - Press



then



. Record the error message.

If the following error message appears, the system unit is at fault. Have the system unit serviced.

XX:XX:XX

ERROR - SYSTEM UNIT XXXX

(X can be any character)

If the following error message appears, the expansion unit is at fault. Have the expansion unit serviced.

XX:XX:XX

ERROR - EXPANSION UNIT XXXX





(X can be any character)

36. Did the following appear on your screen?

40X25 DISPLAY

```
) * + , - . / 0 1 2 3 4 5 6 7 8 9 : ; < = > ? @ A B C D E F G H I J K L M N O  
* + , - . / 0 1 2 3 4 5 6 7 8 9 : ; < = > ? @ A B C D E F G H I J K L M N O P  
+ , - . / 0 1 2 3 4 5 6 7 8 9 : ; < = > ? @ A B C D E F G H I J K L M N O P Q  
, - . / 0 1 2 3 4 5 6 7 8 9 : ; < = > ? @ A B C D E F G H I J K L M N O P Q R  
- . / 0 1 2 3 4 5 6 7 8 9 : ; < = > ? @ A B C D E F G H I J K L M N O P Q R S  
./ 0 1 2 3 4 5 6 7 8 9 : ; < = > ? @ A B C D E F G H I J K L M N O P Q R S T  
/ 0 1 2 3 4 5 6 7 8 9 : ; < = > ? @ A B C D E F G H I J K L M N O P Q R S T U  
0 1 2 3 4 5 6 7 8 9 : ; < = > ? @ A B C D E F G H I J K L M N O P Q R S T U V  
1 2 3 4 5 6 7 8 9 : ; < = > ? @ A B C D E F G H I J K L M N O P Q R S T U V W
```

IS THE SCREEN CORRECT? (Y/N)

- YES - Press  then  and go to Step 37.
- NO - Press  then  . Record the error message.

If the following error message appears, the system unit is at fault. Have the system unit serviced.

```
XX:XX:XX  
ERROR - SYSTEM UNIT      XXXX  
(X can be any character)
```

If the following error message appears, the expansion unit is at fault. Have the expansion unit serviced.

```
XX:XX:XX  
ERROR - EXPANSION UNIT    XXXX  
(X can be any character)
```

37. Did the following appear on your screen?

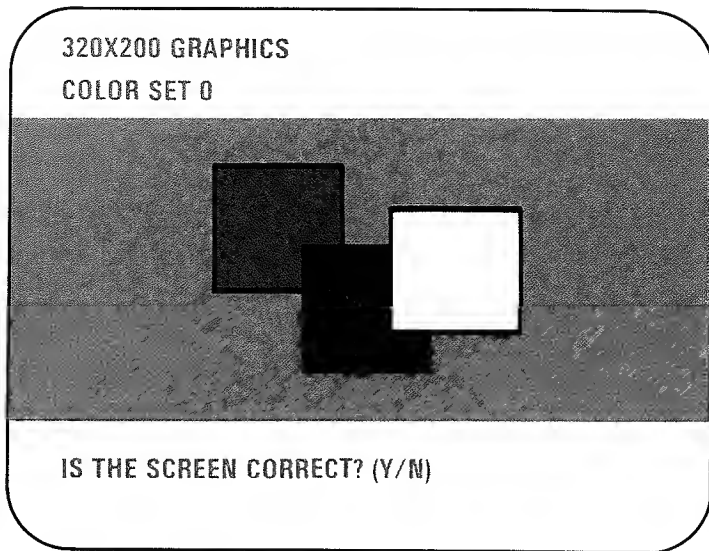

YES - Press  then  and go to Step 38.

NO - Press  then  . Record the error message.

If the following error message appears, the system unit is at fault. Have the system unit serviced.





XX:XX:XX
ERROR - SYSTEM UNIT XXXX
(X can be any character)

If the following error message appears, the expansion unit is at fault. Have the expansion unit serviced.

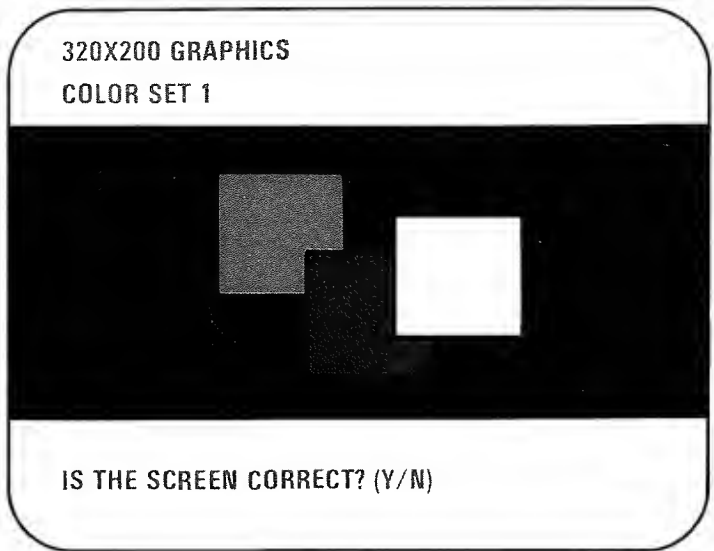
XX:XX:XX
ERROR - EXPANSION UNIT XXXX
(X can be any character)

38. Did the following appear on your screen?



- YES** - Press  then  and go to Step 39.
- NO** - Press  then  . Record the error message.

If the following error message appears, the system unit is at fault. Have the system unit serviced.

XX:XX:XX
ERROR - SYSTEM UNIT XXXX
(X can be any character)

If the following error message appears, the expansion unit is at fault. Have the expansion unit serviced.

XX:XX:XX
ERROR - EXPANSION UNIT XXXX
(X can be any character)

39. Did the following appear on your screen?

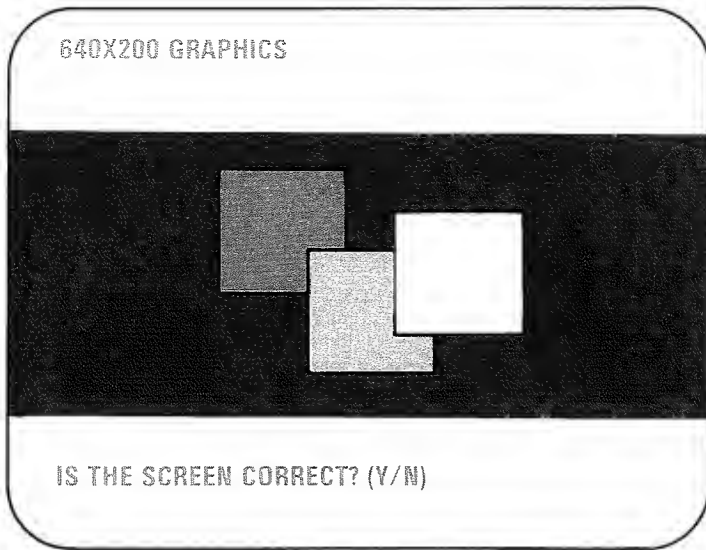

YES - Press  then  and go to Step 40.

NO - Press  then  . Record the error message.

If the following error message appears, the system unit is at fault. Have the system unit serviced.

XX:XX:XX
ERROR - SYSTEM UNIT XXXX
(X can be any character)

If the following error message appears, the expansion unit is at fault. Have the expansion unit serviced.

XX:XX:XX
ERROR - EXPANSION UNIT XXXX
(X can be any character)

40. Did the following appear on your screen?

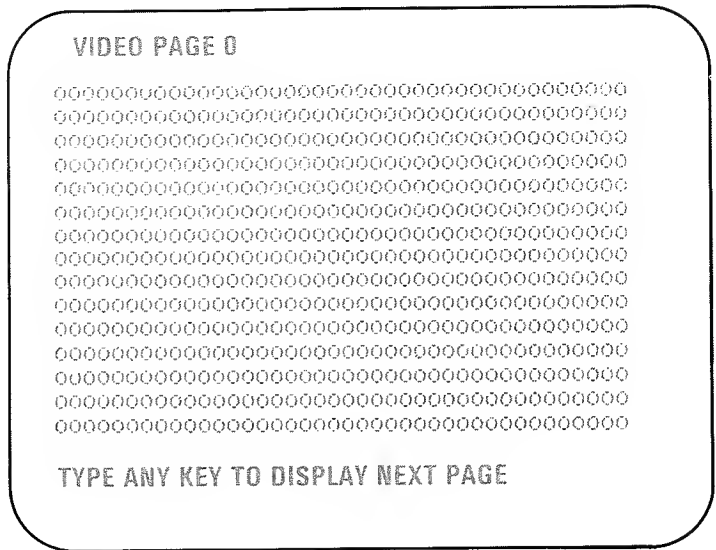

YES - Go to Step 41.

NO - Press  then  . Record the error message.

If the following error message appears, the system unit is at fault. Have the system unit serviced.

XX:XX:XX
ERROR - SYSTEM UNIT XXXX
(X can be any character)

If the following error message appears, the expansion unit is at fault. Have the expansion unit serviced.

XX:XX:XX
ERROR - EXPANSION UNIT XXXX
(X can be any character)

43. Remove the Diagnostics diskette.

Your screen will match the figure below.

XXX will be either 400 or 500.

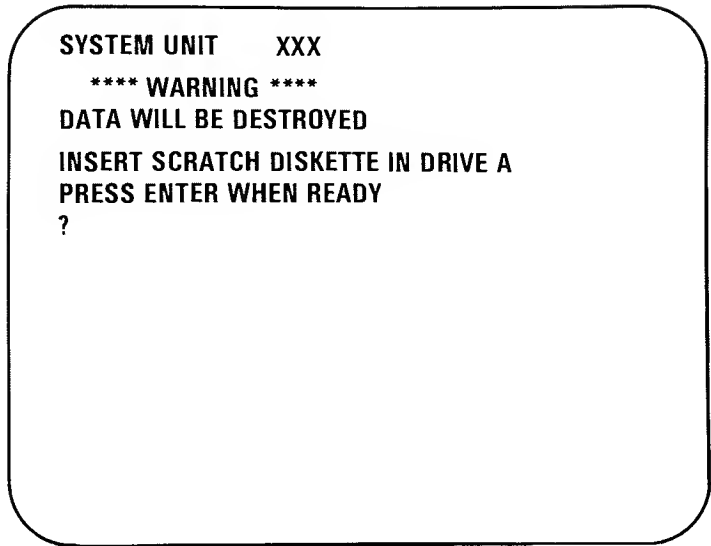

YES - Go to Step 44.

NO - Record the error message.

If the following error message appears, the system unit is at fault. Have the system unit serviced.

XX:XX:XX
ERROR - SYSTEM UNIT XXXX
(X can be any character)

If the following error message appears, the expansion unit is at fault. Have the expansion unit serviced.



XX:XX:XX
ERROR - EXPANSION UNIT XXXX
(X can be any character)

- 44.** Insert a scratch diskette in drive A and press  .
Did the following appear on your screen?

**DISKETTE A IS A XXX K DRIVE
IS THE DRIVE SIZE CORRECT Y/N ?**

If your diskette drive is a 160K drive, XXX will be 160.

If your diskette drive is a 320K drive, XXX will be 320.

YES - Press  then  . If you don't have two diskette drives installed in your system, go to Step 47.

NO - Have the system unit serviced.

45. Did the following appear on your screen?

***** WARNING ***
DATA WILL BE DESTROYED
INSERT SCRATCH DISKETTE IN DRIVE B
PRESS ENTER WHEN READY
?**

Remove the scratch diskette from drive A, place it in
drive B, and press



46. Did the following appear on your screen?

**DISKETTE B IS A XXX K DRIVE
IS THE DRIVE SIZE CORRECT Y/N ?**

If your diskette drive is a 160K drive, XXX will be 160.

If your diskette drive is a 320K drive, XXX will be 320.

YES - Press  then  and go to Step 47.

NO - Have the system unit serviced.

47. Did any of the following errors appear on your screen (X can be any character).

XX:XX:XX
ERROR - SYSTEM UNIT 9XX

XX:XX:XX
ERROR - SYSTEM UNIT 11XX

XX:XX:XX
ERROR - SYSTEM UNIT 12XX

NO - Go to Step 48.

YES - Record the error message.

If the following error message appears, the system unit is at fault. Have the system unit serviced.

XX:XX:XX
ERROR - SYSTEM UNIT XXXX
(X can be any character)

If the following error message appears, the expansion unit is at fault. Have the expansion unit serviced.

XX:XX:XX
ERROR - EXPANSION UNIT XXXX
(X can be any character)

48. Did the following appear on your screen?



**DO YOU HAVE JOY STICKS, PADDLES,
OR NOTHING ATTACHED (J P N)?**

YES - For joy sticks press  and go to Step 49.

For paddles press  and go to Step 52.

For nothing press  and go to Step 56.

NO - Go to Step 56.

49. Press  then .

50. Correct operation of your joy sticks is checked in the following manner:
- Press each button and watch the word **RELEASED** change to **PRESSED**.
 - Move each joy stick and watch the character, A or B, move inside the box.

51. Did all buttons and joy sticks operate correctly?

HOW MANY BUTTONS DD YOU HAVE (2/4)? 2

BUTTON A

BUTTON B

RELEASED

RELEASED

* * *

* * *

* * *

* * *

* A * *

* B * *

* * *

* * *

* * *

* * *

**PRESS AND RELEASE ALL BUTTONS,
EXERCISE ALL JOY STICKS/PADDLES
AND PRESS ANY KEY WHEN DDNE**

YES - Press any key and go to Step 56.

NO - If the game control adapter is installed in the system unit, have the joy sticks and the system unit serviced. If the game control adapter is installed in the expansion unit, have the joy sticks and the expansion unit serviced.

52. Enter the number of paddles attached to your game control adapter (2/4) and press .

53. Enter the same number for the number of buttons and press .

54. Correct operation of your paddles is checked in the following manner:

- Press each button and watch the word **RELEASED** change to **PRESSED**.
- Turn each paddle control and watch the character, A, B, C, or D move inside the box.

55. Did all buttons and paddle controls operate correctly?

HOW MANY BUTTONS DO YOU HAVE (2/4)?

BUTTON A	BUTTON B	BUTTON C	BUTTON D
RELEASED	RELEASED	RELEASED	RELEASED
*****		*****	
* A *		* B *	
*****		*****	
*****		*****	
* C *		* D *	
*****		*****	

**PRESS AND RELEASE ALL BUTTONS,
EXERCISE ALL JOY STICKS/PADDLES
AND PRESS ANY KEY WHEN DONE**

YES - Press any key and go to Step 56.

NO - If the game control adapter is installed in the system unit, have the paddles and the system unit serviced. If the game control adapter is installed in the expansion unit, have the paddles and the expansion unit serviced.

56. Did an error appear on your screen?

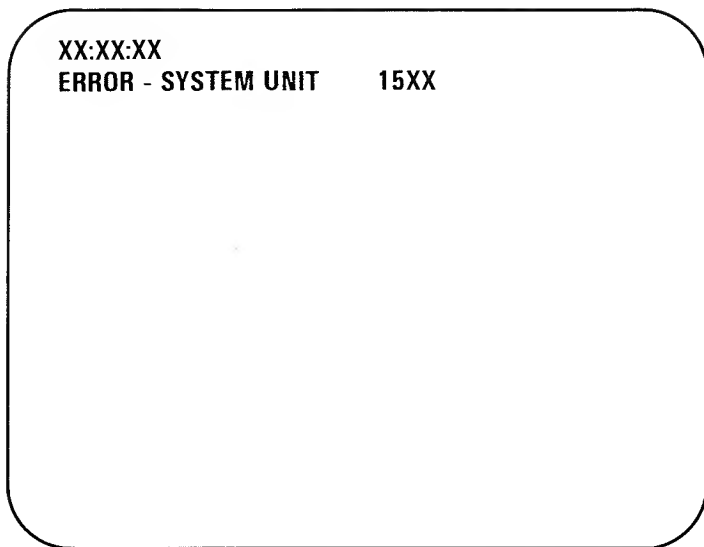

NO - Go to Step 57.

YES - Record the error message.

If the following error message appears, the system unit is at fault. Have the system unit serviced.

XX:XX:XX
ERROR - SYSTEM UNIT XXXX
(X can be any character)

If the following error message appears, the expansion unit is at fault. Have the expansion unit serviced.

XX:XX:XX
ERROR - EXPANSION UNIT XXXX
(X can be any character)

57. Do you have a fixed disk drive installed in your system?

NO - Go to Step 61.

YES - The following will appear on your screen.

***** WARNING *****
DATA ON CYLINDER 305 WILL BE
OVERWRITTEN BY FIXED DISK WRITE TESTS
DO YOU WANT TO INCLUDE FIXED DISK
WRITE TESTS ON DRIVE C: (Y/N) ?

Press  then  and go to Step 58.

58. Did the following appear on your screen?

```
*** WARNING ***  
DATA ON CYLINDER 305 WILL BE  
OVERWRITTEN BY FIXED DISK WRITE TESTS  
DO YOU WANT TO INCLUDE FIXED DISK  
WRITE TESTS ON DRIVE C: (Y/N) ? y  
PERFORMING SEEK TEST  
PERFORMING WRITE TEST  
PERFORMING TRACK ZERO TEST  
PERFORMING SURFACE SCAN  
PLEASE STAND BY
```

YES - For one fixed disk drive installed in your system, go to Step 61. If you have a second fixed disk drive installed in your system, go to Step 59.

NO - Record the error message.

If the following error message appears, the system unit is at fault. Have the system unit serviced.

```
XX:XX:XX  
ERROR - SYSTEM UNIT    XXXX  
(X can be any character)
```

If the following error message appears, the expansion unit is at fault. Have the expansion unit serviced.

```
XX:XX:XX  
ERROR - EXPANSION UNIT  XXXX  
(X can be any character)
```

59. Did the following appear on your screen?

***** WARNING ***
DATA ON CYLINDER 305 WILL BE
OVERWRITTEN BY FIXED DISK WRITE TESTS
DO YOU WANT TO INCLUDE FIXED DISK
WRITE TESTS ON DRIVE D: (Y/N) ?**

YES - Press  then  and go to Step 60.

NO - Record the error message.

If the following error message appears, the system unit is at fault. Have the system unit serviced.

XX:XX:XX

ERROR - SYSTEM UNIT XXXX

(X can be any character)

If the following error message appears, the expansion unit is at fault. Have the expansion unit serviced.

XX:XX:XX

ERROR - EXPANSION UNIT XXXX

(X can be any character)

60. Did the following appear on your screen?

**DO YOU WANT TO INCLUDE FIXED DISK
WRITE TESTS ON DRIVE D: (Y/N) ? y
PERFORMING SEEK TEST
PERFORMING WRITE TEST
PERFORMING TRACK ZERO TEST
PERFORMING SURFACE SCAN
PLEASE STAND BY**

YES - Go to Step 61.

NO - Record the error message.

If the following error message appears, the system unit is at fault. Have the system unit serviced.

**XX:XX:XX
ERROR - SYSTEM UNIT XXXX
(X can be any character)**

If the following error message appears, the expansion unit is at fault. Have the expansion unit serviced.

**XX:XX:XX
ERROR - EXPANSION UNIT XXXX
(X can be any character)**

61. If an IBM printer is attached, one of the following printer test patterns should result:

IBM 80 CPS Matrix Printer

```

! " # $ % & ' ( ) * + , - . /
0 1 2 3 4 5 6 7 8 9 : ; < = > ?
@ A B C D E F G H I J K L M N O
P Q R S T U V W X Y Z [ \ ] ^ _
` a b c d e f g h i j k l m n o
p q r s t u v w x y z { | } ~
! " # $ % & ' ( ) * + , - . /
0 1 2 3 4 5 6 7 8 9 i j k l m n o p q r s t u v w x y z
@ A B C D E F G H I J K L M N O
P Q R S T U V W X Y Z [ \ ] ^ _
` a b c d e f g h i j k l m n o
p q r s t u v w x y z { | } ~
! " # $ % & ' ( ) * + , - . /
` 7 1 7 5 7 5 7 5 7 5

```

IBM Graphics Printer

```

! " # $ % & ' ( ) * + , - . /
0 1 2 3 4 5 6 7 8 9 : ; < = > ?
@ A B C D E F G H I J K L M N O
P Q R S T U V W X Y Z [ \ ] ^ _
` a b c d e f g h i j k l m n o
p q r s t u v w x y z { | } ~
! " # $ % & ' ( ) * + , - . /
0 1 2 3 4 5 6 7 8 9 i j k l m n o p q r s t u v w x y z
@ A B C D E F G H I J K L M N O
P Q R S T U V W X Y Z [ \ ] ^ _
` a b c d e f g h i j k l m n o
p q r s t u v w x y z { | } ~
! " # $ % & ' ( ) * + , - . /
á í ó ù ñ ñ ñ ñ ñ ñ ñ ñ ñ ñ ñ ñ ñ ñ ñ ñ ñ ñ ñ ñ ñ ñ ñ
Σ π ρ Γ σ Σ β Γ σ Σ β Γ σ @ Ω
□ □ □ □

```

62. Did the printer test run error free and the printer test pattern print correctly?

YES - Go to Step 63.

NO - Record any error message. Go to "Printer Problem Determination Procedures."

63. You have completed the Problem Determination Procedures with no failures. Remove the Diagnostics diskette and return it to the back of this manual. Your IBM Personal Computer should be ready to load your operating system.

If you should encounter further problems, contact your place of purchase for additional information.

IBM Printer Problem Determination Procedures

Before you proceed, follow these preliminary steps:

- 1.** Check your wall outlet for proper operation (use a working lamp).
- 2.** Verify that your printer cable is properly connected.
- 3.** Verify that the printer is plugged into the wall outlet and is turned on.

Did you find any problem while following the above steps?

YES - Correct the problem and run the Diagnostics again.

NO - Go to Step 4.

- 4.** Set the Power switches on the printer, system unit (and expansion unit, if attached) to Off.
- 5.** Disconnect the printer cable from the printer.
- 6.** Run the printer self-test.

If you need help in doing this, refer to Section 3, "Operations," for the procedure.

Did the self-test run without failures?

YES - Go to Step 12.

NO - Go to Step 7.

- 7.** Check that your ribbon is installed properly.
- 8.** Check that your forms are inserted properly.
- 9.** Check that there are no obstructions in the forms path.
- 10.** Check that the tractors are adjusted properly.

If you need help with any of the above, refer to Section 3, "Operations."

Did you find any problem while following the above steps?

YES - Correct the problem.

NO - Go to Step 11.

- 11.** Do you have any of these problems?
 - a. Your printer beeps even though the paper is installed properly.
 - b. Your printer does not beep when it is out of paper.
 - c. Some of the lights on the control panel do not work.
 - d. Your printer continues to print when it is out of paper.

YES - Have your printer serviced.

NO - Go to Step 15.

12. Did you receive any of the following error messages?

199

432

901

1401

YES - Go to Step 13.

NO - Go to Step 15.

13. Leave the printer cable disconnected from the printer and run the Diagnostics again.

Note: "Matrix Printer" will be missing from the menu of installed devices when you run Diagnostics this time. Verify your installed devices correctly (without the printer).

14. Did you receive the same error message when you ran Diagnostics this time?

YES - The problem is probably in the unit (system or expansion) that has the card your printer was attached to.

NO - Have the printer and cable serviced.

15. Your printer is also controlled by program commands from the system unit. If you have a printer problem only while running a particular program, examine the program thoroughly for commands being sent to the printer causing it to produce undesired results.

IBM Color Display Problem Determination Procedures

If your IBM Color Display requires service, it must be returned with the power cord.

1. Set the Power control to On.

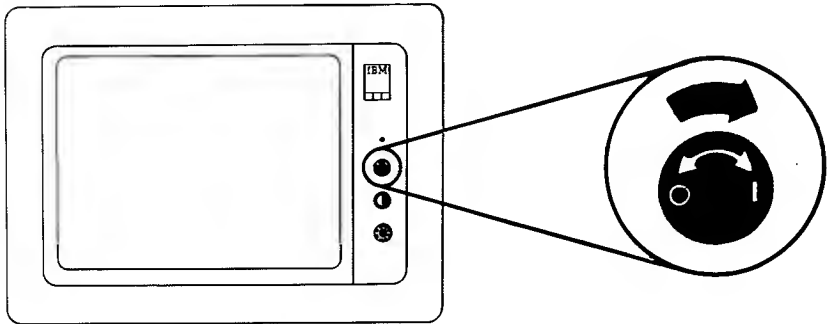

2. Is the Power-On indicator lit?

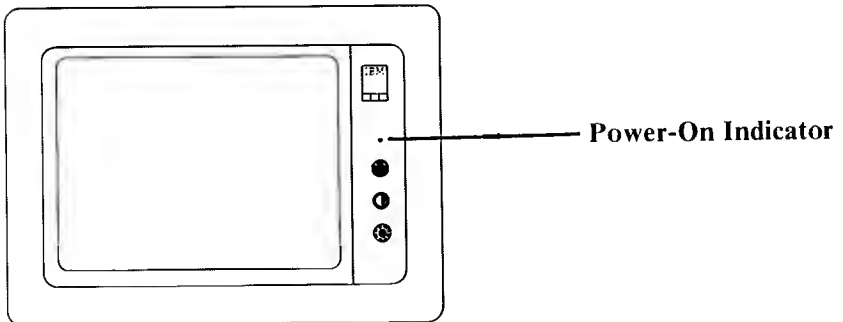

YES - Go to Step 3.

NO - Check that the power cord is plugged into a functioning wall outlet and the rear of the display. If it is, have the display serviced.

3. Set the Power switch on the system unit (and expansion unit, if attached) to Off.
4. Set the Brightness and Contrast controls fully clockwise.

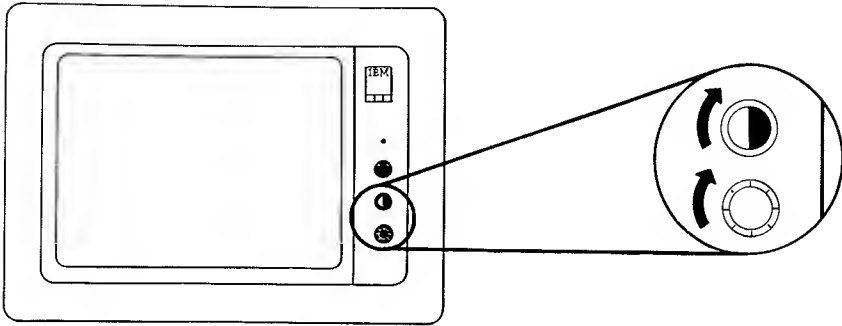

5. Turn the Vertical Size control fully counterclockwise. A black area should appear across the top and the bottom of the screen.

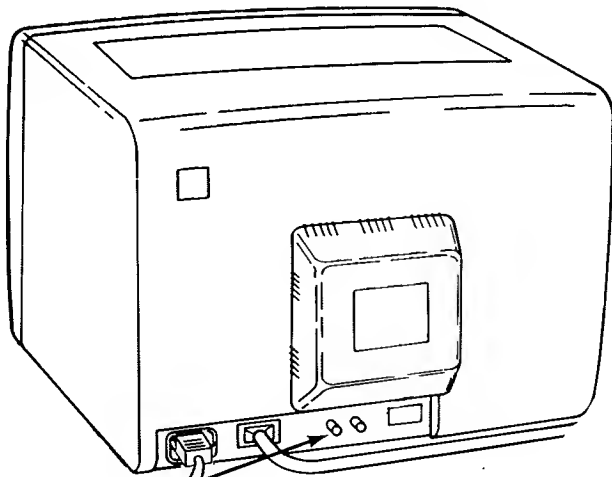

**Vertical Size
Control**

6. Does a black area appear across the top and the bottom of the screen?

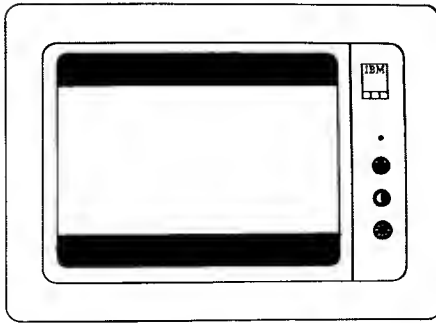

YES - Go to Step 7.

NO - Have the display serviced.

7. Are the black areas at the top and bottom of the screen approximately equal in size?

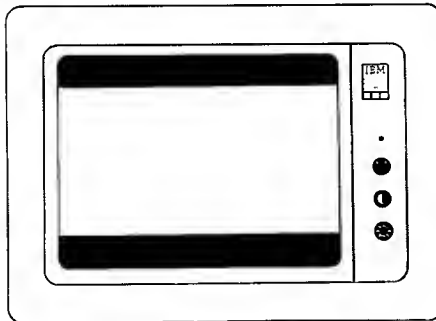

YES - Go to Step 8.

NO - Have the display serviced.

- 8.** Turn the Vertical Size control clockwise until the black areas at the top and bottom of the screen just disappear. If one of the black areas disappears before the other, continue to turn the control until the second black area is gone.

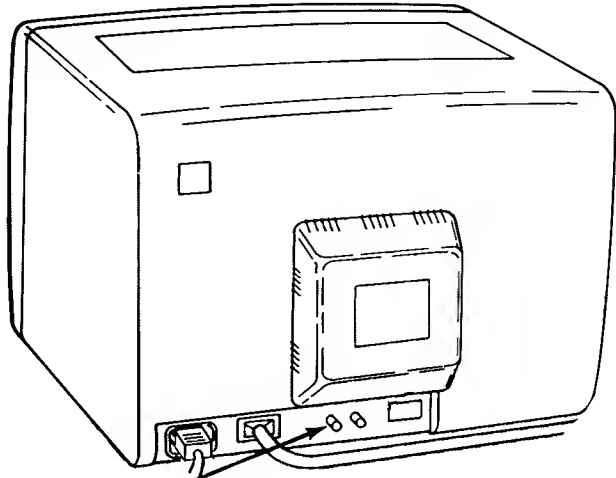

**Vertical Size
Control**

- 9.** Is the screen all white?

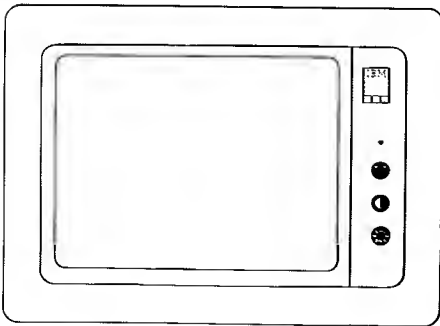

YES - Go to Step 14.

NO - Go to Step 10.

10. Set the Power control to Off.
11. Disconnect the display's signal cable from the Color/Graphics Monitor Adapter.

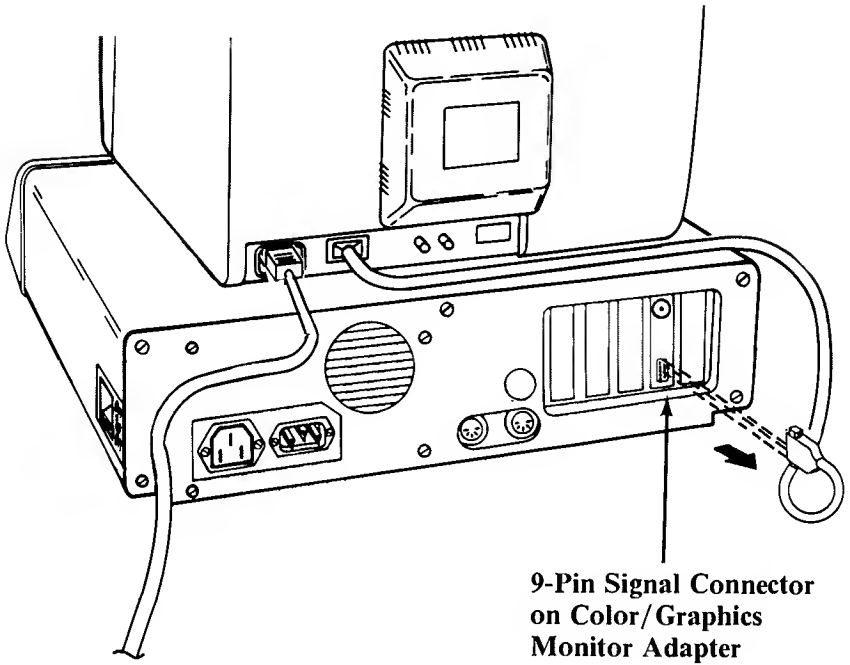

12. Set the Power control to On.
13. Is the screen white?
 - YES - Have the unit serviced that contains the Color/Graphics Monitor Adapter.
 - NO - Have the display serviced.
14. While watching the screen, set the Power switch on the expansion unit (if attached) and the system unit to On.

- 15.** Did the screen change from white to black as soon as the Power switch on the unit having the Color/Graphics Monitor Adapter was set to On? (This totally black condition may last only 3 seconds before the display changes again.)

YES - Go to Step 16.

NO - Have the display serviced.

- 16.** Wait for the Power-on self test (POST) to complete. The IBM Personal Computer BASIC message will appear (if a diskette is not loaded or an operating system is not booted from the fixed disk drive) with a blinking cursor.

```
The IBM Personal Computer Basic Version  
CX.XX Copyright IBM Corp. XXXX  
***** Bytes free  
OK
```

```
1LIST 2RUN 3LOAD" 4SAVE 5CONT 6LPT1 '7TRON 8TROFF 9KEY 0SCREEN
```

- 17.** Is your screen blank?

YES - Have the unit serviced that contains the Color/Graphics Monitor Adapter.

NO - Go to Step 18.

- 18.** Is your screen stable?

YES - Go to Step 21.

NO - Go to Step 19.

- 19.** Turn the Vertical Hold control clockwise as far as it will go, then turn it counterclockwise until the screen stops rolling and is stable.

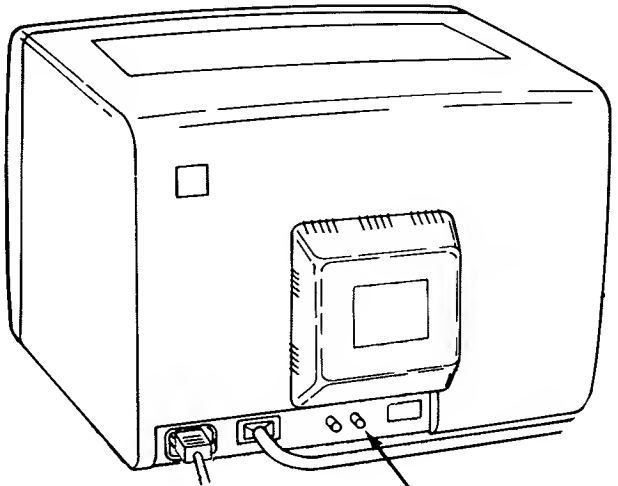

**Vertical Hold
Control**

- 20.** Were you able to make the screen stable?
- YES** - Go to Step 21.
- NO** - Have the display serviced.
- 21.** Look at the screen. Does it have white characters on a dark background?
- YES** - Go to Step 27.
- NO** - Go to Step 22.

- 22.** Set the Power switch on the system unit (and expansion unit, if attached) to Off.
- 23.** Set the display's Power control to Off.
- 24.** Disconnect the display's signal cable from the Color/Graphics Monitor Adapter.
- 25.** Set the display's Power control to On.
- 26.** Is the screen white?
YES - Have the unit serviced that contains the Color/Graphics Monitor Adapter.
NO - Have the display serviced.
- 27.** Turn the Brightness control fully counterclockwise.

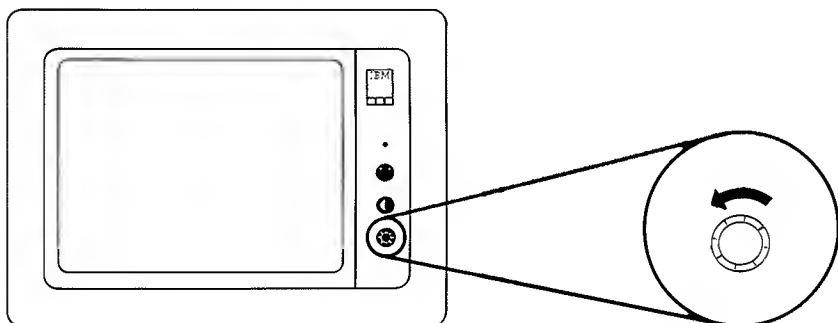

- 28.** Does the intensity of the characters decrease?
YES - Go to Step 29.
NO - Have the display serviced.

- 29.** Turn the Brightness control fully clockwise. Turn the Contrast control fully counterclockwise.

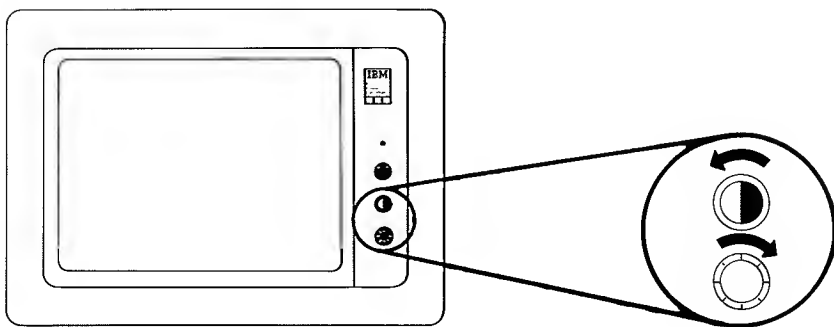

- 30.** Does the intensity of the characters decrease?

YES - Go to Step 31.

NO - Have the display serviced.

31. Turn the Contrast control fully clockwise. Look at the following examples.



Too Dim

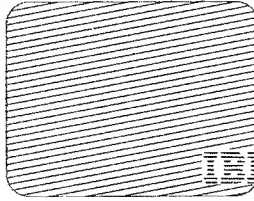

Too Wide

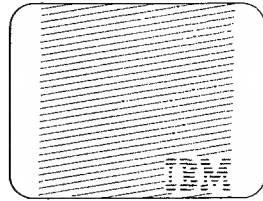

Too Narrow

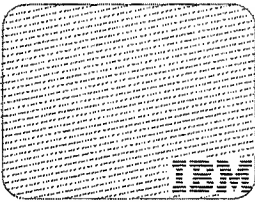

Out of Focus

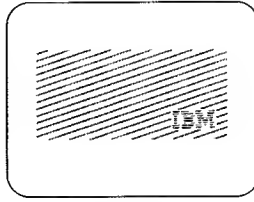

Shrunk

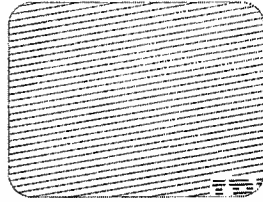

Characters shifted left or right or up and down off the display area

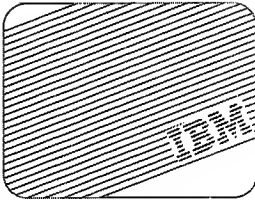

Tilted

32. Is your problem similar to one of the examples?

YES - Have the display serviced.

NO - Go to "Diagnostic Testing" in this section.

SECTION 5. OPTIONS

Introduction

This section has been provided to contain the option installation instructions for the options you purchased for your IBM Personal Computer. After your option has been installed, file the installation instructions under the appropriate bleeder tab, as shown in the figure below.

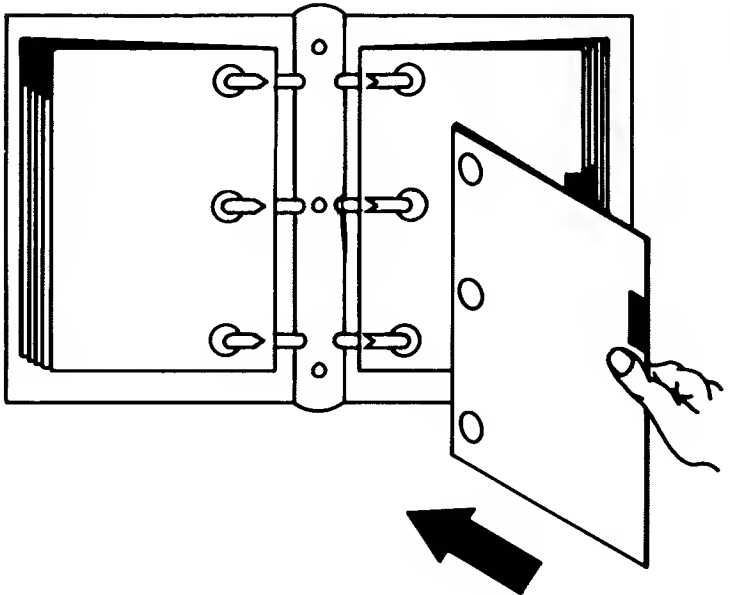

SECTION 5. OPTIONS

Contents

Introduction

IBM Monochrome Display

IBM Monochrome Display and Printer Adapter

Color/Graphics Monitor Adapter

IBM Color Display

IBM Printers

Printer Adapter

5¼ Inch Diskette Drive

5¼ Inch Diskette Drive Adapter

16KB Memory Module Kit

64KB Memory Module Kit

64/256KB Memory Expansion

Game Control Adapter

Asynchronous Communications Adapter

Prototype Card

**Synchronous Data Link Control (SDLC)
Communications Adapter**

IBM Communications Adapter Cable

IBM Personal Computer Expansion Unit

**Synchronous Data Link Control (SDLC)
Communications Adapter**

IBM Communications Adapter Cable

DISPLAYS

PRINTERS

DISKETTE/DISK

MEMORY

GENERAL

COMMUNICATIONS

SWITCH SETTINGS

Notes:

Switch Setting Charts

Use the illustrations below to determine which system board is in your system unit.

- A 64KB-256KB system board has a "B" stamped on the rear panel and 64KB-256KB CPU printed on the system board. If you have this system board, go to page 5-28.
- A 16KB-64KB system board has no identification on the rear panel and 16KB-64KB CPU is printed on the system board. If you have this system board, go to page 5-2.

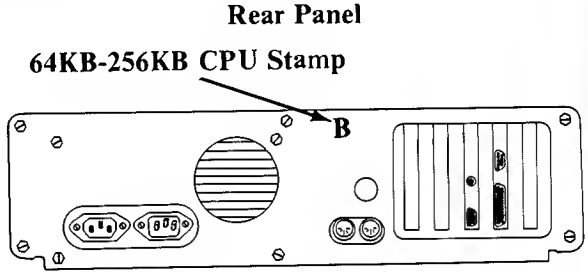

No "B" stamp indicates a 16KB-64KB CPU.

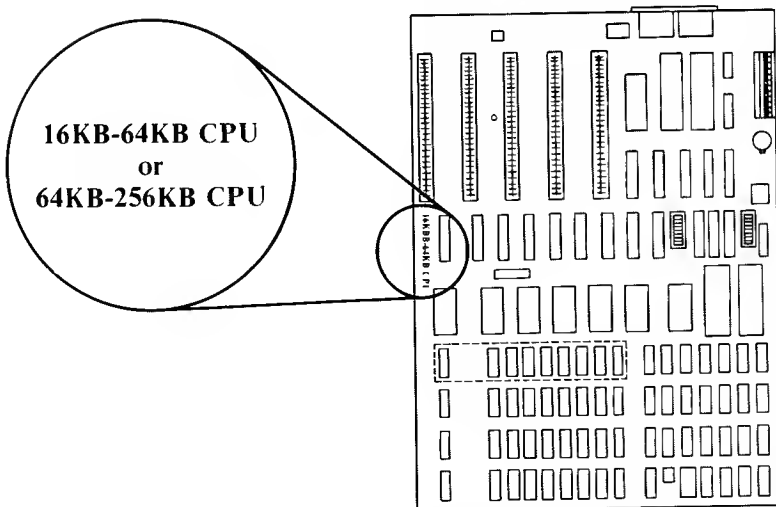

16K-64K System Board

To use the following switch setting charts, your system should have no "B" stamped on the rear panel and the system board should have 16KB-64KB CPU printed on the side.

Switch Setting Charts

System Board Switches

WARNING: Before you change any switch settings, make a note of how the switches are presently set.

Switch Block 1

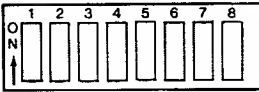

Switch	Function
--------	----------

- | | |
|-------|--|
| 1,7,8 | Number of 5-1/4 inch diskette drives installed |
| 2 | Coprocessor |
| 3,4 | System board memory switches |
| 5,6 | Type(s) of display(s) connected |

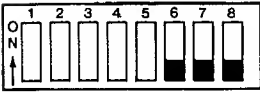

Switch Block 2



Switch	Function
--------	----------

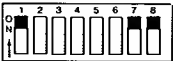
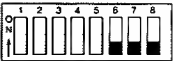
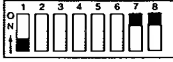
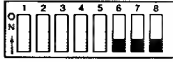

- | | |
|-----------|------------------------------------|
| 1,2,3,4,5 | Amount of memory options installed |
| 6,7,8 | Always in the Off position |

Number of 5-1/4 Inch Diskette Drives Installed

	Switch Block 1	Switch Block 2
0 - Drives		
1 - Drive		
2 - Drives		

Type(s) of Display(s) Connected

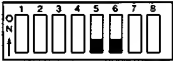
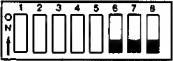
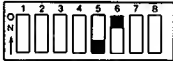
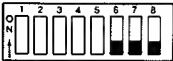
WARNING: If an IBM Monochrome Display is connected to your system, Switch Block 1, switches 5 and 6, must always be Off. Damage to your display can result with any other switch settings.

IBM Monochrome Display (or IBM Monochrome Display plus another display)	Switch Block 1	Switch Block 2
		
Color Display (Do not use if an IBM Monochrome Display is connected)	Switch Block 1	Switch Block 2
		
		40x25 Mode
		
		80x25 Mode

Note: The 40x25 mode means there will be 40 characters across the screen and 25 lines down the screen. The 40x25 is normally used with a home television. The 80x25 mode means there will be 80 characters across the screen and 25 lines down the screen. The 80x25 mode, when used with home televisions and various displays, can cause loss of character quality.

Math Coprocessor

Switch Block 1

Switch Block 2

With Math Coprocessor

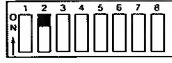

Without Math Coprocessor

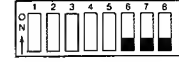
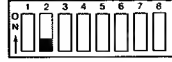

Memory Switch Settings (16KB-64KB CPU) System Board

16K Total Memory

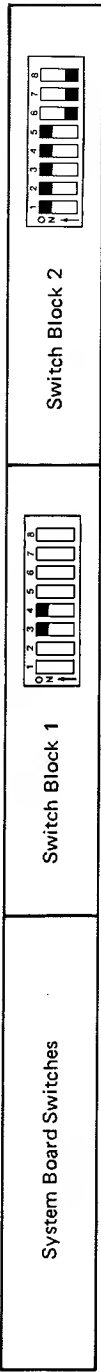

32K Total Memory

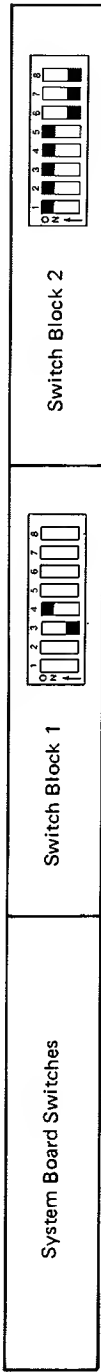

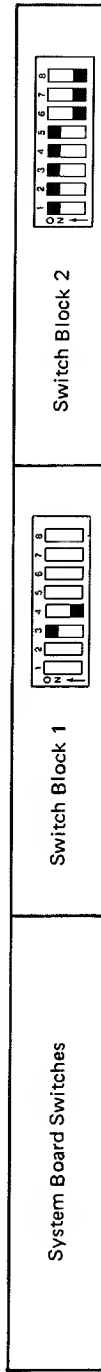

48K Total Memory



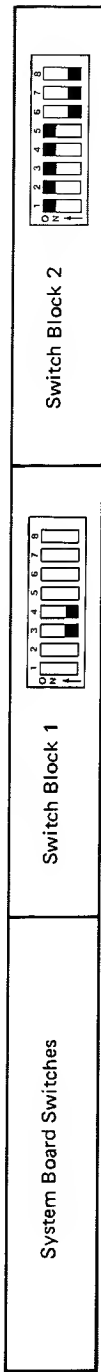



64K Total Memory



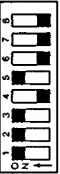

96K Total Memory
32K + (64K on System Board)

System Board Switches	 <p>Switch Block 1</p>	 <p>Switch Block 2</p>
1 - 32K option	64/256K Option Card Switches	64K Option Card Switches
		32K Option Card Switches

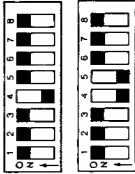



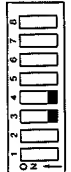

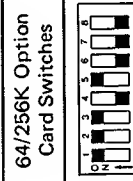
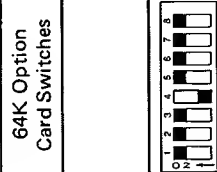
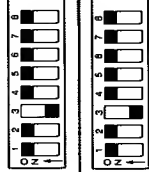
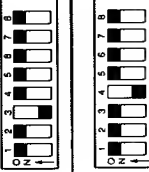
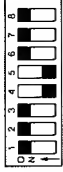
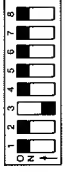

**128K Total Memory
64K + (64K on System Board)**

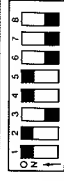
System Board Switches	Switch Block 1 	Switch Block 2 	
1 - 64/256K option with 64K installed	64/256K Option Card Switches 	64K Option Card Switches 	32K Option Card Switches
1 - 64K option			
2 - 32K options			





**160K Total Memory
96K + (64K on System Board)**

System Board Switches	Switch Block 1 	Switch Block 2 
1 - 64/256K option with 64K installed 1 - 32K option	64/256K Option Card Switches 	64K Option Card Switches 
1 - 64K option 1 - 32K option		32K Option Card Switches 
3 - 32K options		  





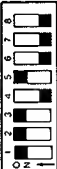
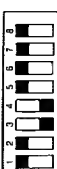

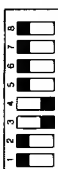
**192K Total Memory
128K + (64K on System Board)**

System Board Switches	Switch Block 1	Switch Block 2
1 - 64/256K option with 64K installed 1 - 64K option		
2 - 64K options		
1 - 64/256K option with 64K installed 2 - 32K options		
1 - 64K option 2 - 32K options		
1 - 64/256K option with 128K installed		

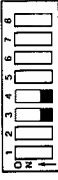

**224K Total Memory
160K + (64K on System Board)**

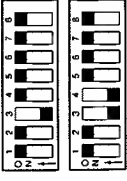
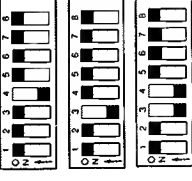
System Board Switches	Switch Block 1	Switch Block 2
1 - 64/256K option with 64K installed 1 - 64K option 1 - 32K option		
2 - 64K options 1 - 32K option		
1 - 64/256K option with 128K installed 1 - 32K option		

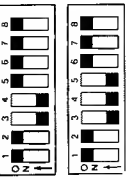

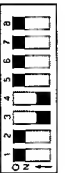
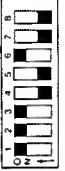
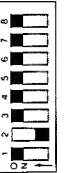

256K Total Memory
192K + (64K on System Board)

System Board Switches	Switch Block 1	Switch Block 2	
1 - 64/256K option with 192K installed			32K Option Card Switches
1 - 64/256K option with 128K installed 1 - 64K option			64K Option Card Switches
1 - 64/256K option with 64K installed 2 - 64K options			64K Option Card Switches
3 - 64K options			64K Option Card Switches
1 - 64/256K option with 128K installed 2 - 32K options			

**288K Total Memory
224K + (64K on System Board)**

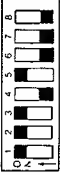
System Board Switches	Switch Block 1 	Switch Block 2 
1 - 64/256K option with 192K installed 1 - 32K option	64/256K Option Card Switches 	64K Option Card Switches 
1 - 64/256K option with 128K installed 1 - 64K option 1 - 32K option	64/256K Option Card Switches 	32K Option Card Switches 

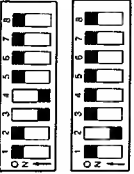

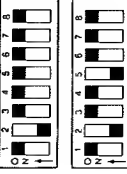
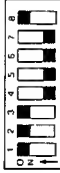

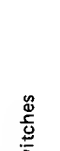
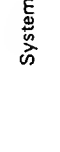
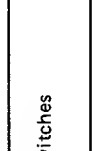
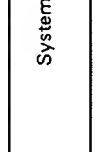

**320K Total Memory
256K + (64K on System Board)**

System Board Switches	Switch Block 1	Switch Block 2
<p>1 - 64/256K option with 128K installed 2 - 64K options</p>	<p>64/256K Option Card Switches</p> 	<p>32K Option Card Switches</p> 
<p>1 - 64/256K option with 192K installed 1 - 64K option</p>	<p>64/256K Option Card Switches</p> 	<p>64K Option Card Switches</p> 
<p>1 - 64/256K option with 192K installed 2 - 32K options</p>	<p>64/256K Option Card Switches</p> 	<p>32K Option Card Switches</p> 
<p>1 - 64/256K option with 256K installed</p>	<p>64/256K Option Card Switches</p> 	



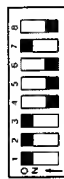

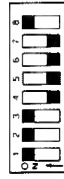
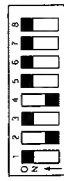
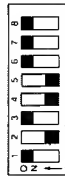

**352K Total Memory
288K + (64K on System Board)**

System Board Switches	Switch Block 1	Switch Block 2
<ul style="list-style-type: none"> 1 - 64/256K option with 192K installed 1 - 64K option 1 - 32K option 		
<ul style="list-style-type: none"> 1 - 64/256K option with 256K installed 1 - 32K option 		



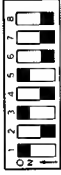

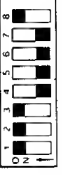
384K Total Memory
320K + (64K on System Board)

System Board Switches	Switch Block 1	Switch Block 2			
1 - 64/256K option with 192K installed 2 - 64K options			64/256K Option Card Switches	64K Option Card Switches	32K Option Card Switches
1 - 64/256K option with 256K installed 1 - 64/256K option with 64K installed				 	
1 - 64/256K option with 256K installed 1 - 64K option					
1 - 64/256K option with 256K installed 2 - 32K options					 

**416K Total Memory
352K + (64K on System Board)**

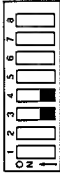
System Board Switches		
<p>1 - 64/256K option with 256K installed 1 - 64/256K option with 64K installed 1 - 32K option</p>	<p>64/256K Option Card Switches</p>  	<p>64K Option Card Switches</p> 
<p>1 - 64/256K option with 256K installed 1 - 64K option 1 - 32K option</p>		

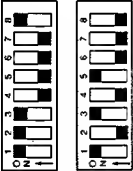

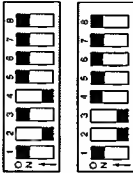
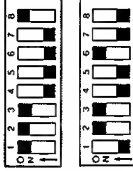

**448K Total Memory
384K + (64K on System Board)**

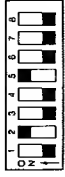
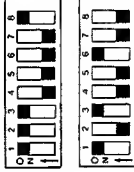
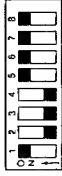
System Board Switches	Switch Block 1 	Switch Block 2 	
<p>1 - 64/256K option with 256K installed 1 - 64/256K option with 64K installed 1 - 64K option</p>	<p>64/256K Option Card Switches</p> 	<p>64K Option Card Switches</p> 	<p>32K Option Card Switches</p>
<p>1 - 64/256K option with 256K installed 2 - 64K options</p>			
<p>1 - 64/256K option with 256K installed 1 - 64/256K option with 128K installed</p>			



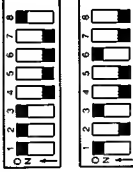

**480K Total Memory
416K + (64K on System Board)**

System Board Switches	Switch Block 1	Switch Block 2
<p>1 - 64/256K option with 256K installed 1 - 64/256K option with 128K installed 1 - 32K option</p>		
	<p>64/256K Option Card Switches</p> 	<p>64K Option Card Switches</p>
		<p>32K Option Card Switches</p> 



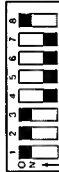

**512K Total Memory
448K + (64K on System Board)**

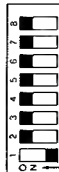
System Board Switches	Switch Block 1	Switch Block 2
<p>1 - 64/256K option with 256K installed 1 - 64/256K option with 128K installed 1 - 64K option</p>	<p>64/256K Option Card Switches</p> 	<p>64K Option Card Switches</p> 
<p>1 - 64/256K option with 256K installed 1 - 64/256K option with 192K installed</p>	<p>64/256K Option Card Switches</p> 	<p>64K Option Card Switches</p> 

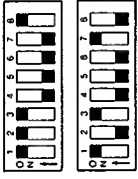

**544K Total Memory
480K + (64K on System Board)**

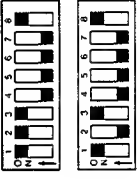
System Board Switches	Switch Block 1 	Switch Block 2 
	64/256K Option Card Switches  	64K Option Card Switches
<p>1 - 64/256K option with 256K installed 1 - 64/256K option with 192K installed 1 - 32K option</p>		32K Option Card Switches 



**576K Total Memory
512K + (64K on System Board)**

System Board Switches	Switch Block 1	Switch Block 2
<p>1 - 64/256K option with 256K installed 1 - 64/256K option with 192K installed 1 - 64K option</p>	<p>64/256K Option Card Switches</p> 	<p>64K Option Card Switches</p> 
<p>2 - 64/256K option with 256K installed</p>		<p>32K Option Card Switches</p> 

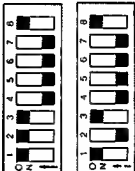
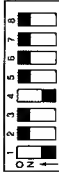



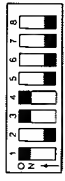
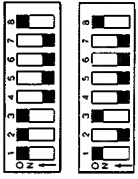

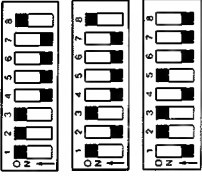

608K Total Memory
544K + (64K on System Board)

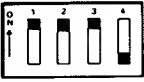
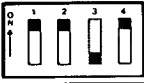
System Board Switches	 <p>Switch Block 1</p>	 <p>Switch Block 2</p>
<p>2 - 64/256K option with 256K installed 1 - 32K option</p>	<p>64/256K Option Card Switches</p> 	<p>64K Option Card Switches</p>
		<p>32K Option Card Switches</p> 

**640K Total Memory
576K + (64K on System Board)**

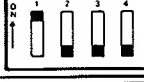
System Board Switches	Switch Block 1 	Switch Block 2 
2 - 64/256K option with 256K installed 1 - 64K option	64/256K Option Card Switches 	64K Option Card Switches 
2 - 64/256K option with 256K installed 1 - 64/256K option with 64K installed	64/256K Option Card Switches 	32K Option Card Switches

Extender Card Switch Settings

System Memory	Extender Card Switch Block	Memory Segment
16K to 64K		1
96K to 128K		2
160K to 192K		3
224K to 256K		4
288K to 320K		5
352K to 384K		6
416K to 448K		7
480K to 512K		8
544K to 576K		9
608K to 640K		A

Notes:

64K-256K System Board

To use the following switch setting charts, your system should have a "B" stamped on the rear panel and the system board should have 64KB-256KB CPU printed on the side.

Notes:

Switch Setting Charts

System Board Switches

WARNING: Before you change any switch settings, make a note of how the switches are presently set.

Switch Block 1

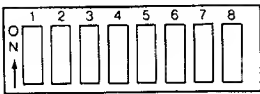

Switch	Function
--------	----------

- | | |
|-------|--|
| 1,7,8 | Number of 5-1/4 inch diskette drives installed |
| 2 | Coprocessor |
| 3,4 | System board memory switches |
| 5,6 | Type(s) of display(s) connected |

Switch Block 2

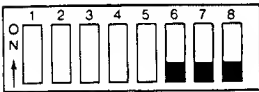

Switch	Function
--------	----------

- | | |
|-----------|------------------------------------|
| 1,2,3,4,5 | Amount of memory options installed |
| 6,7,8 | Always in the Off position |

Number of 5-1/4 Inch Diskette Drives Installed

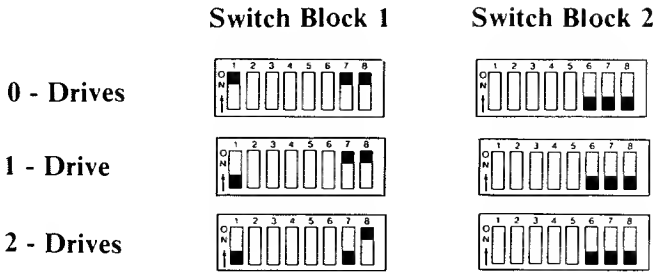

Type(s) of Display(s) Connected

WARNING: If an IBM Monochrome Display is connected to your system, Switch Block 1, switches 5 and 6, must always be Off. Damage to your display can result with any other switch settings.

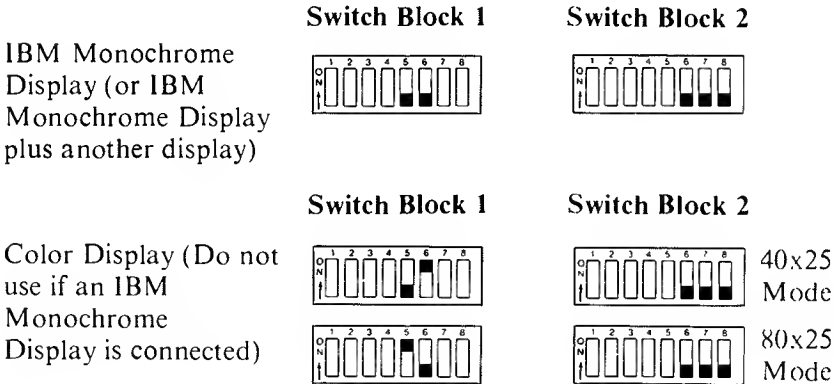

Note: The 40x25 mode means there will be 40 characters across the screen and 25 lines down the screen. The 40x25 is normally used with a home television. The 80x25 mode means there will be 80 characters across the screen and 25 lines down the screen. The 80x25 mode, when used with home televisions and various displays, can cause loss of character quality.

Math Coprocessor

Switch Block 1

Switch Block 2

With Math Coprocessor

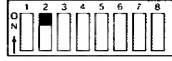

Without Math Coprocessor

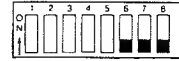
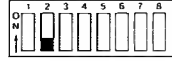

Memory Switch Settings

(64KB-256KB CPU) System Board

64K Total Memory

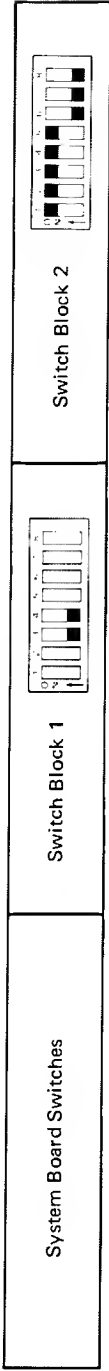

128K Total Memory

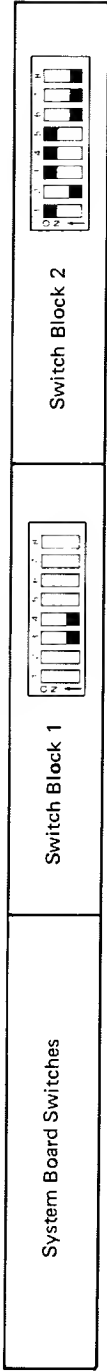

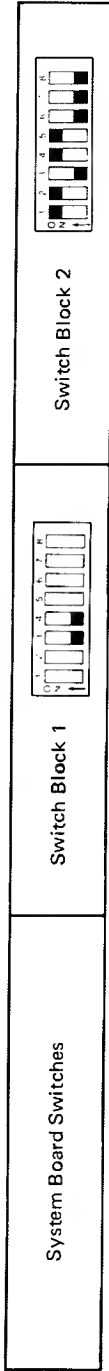

192K Total Memory



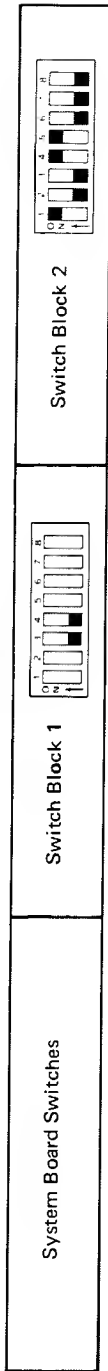



256K Total Memory





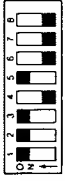

**288K Total Memory
32K + (256K on System Board)**

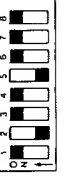
System Board Switches	 <p align="center">Switch Block 1</p>	 <p align="center">Switch Block 2</p>
1 - 32K option	64/256K Option Card Switches	32K Option Card Switches







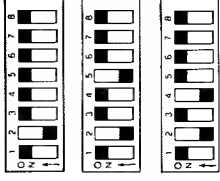

**320K Total Memory
64K + (256K on System Board)**

System Board Switches		Switch Block 1		Switch Block 2	
	64/256K Option Card Switches		64K Option Card Switches		32K Option Card Switches
1 - 64/256K option with 64K installed					
1 - 64K option					
2 - 32K options					

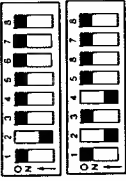
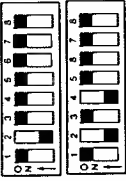

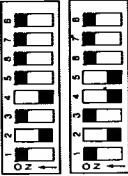

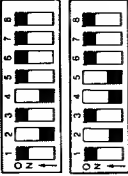

**352K Total Memory
96K + (256K on System Board)**

System Board Switches	Switch Block 1	Switch Block 2
1 - 64/256K option with 64K installed 1 - 32K option		
1 - 64K option 1 - 32K option		
3 - 32K options		





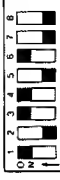

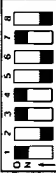

**384K Total Memory
128K + (256K on System Board)**

System Board Switches	Switch Block 1	Switch Block 2
1 - 64/256K option with 64K installed 1 - 64K option		
2 - 64K options		
1 - 64/256K option with 64K installed 2 - 32K options		
1 - 64K option 2 - 32K options		
1 - 64/256K option with 128K installed		



**416K Total Memory
160K + (256K on System Board)**

System Board Switches	Switch Block 1	Switch Block 2
1 - 64/256K option with 64K installed 1 - 64K option 1 - 32K option		
2 - 64K options 1 - 32K option		
1 - 64/256K option with 128K installed 1 - 32K option		

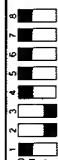

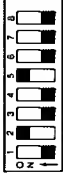

**448K Total Memory
192K + (256K on System Board)**

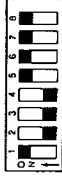
System Board Switches	Switch Block 1	Switch Block 2	
1 - 64/256K option with 192K installed			32K Option Card Switches
1 - 64/256K option with 128K installed 1 - 64K option			64K Option Card Switches
1 - 64/256K option with 64K installed 2 - 64K options			64K Option Card Switches
3 - 64K options			64K Option Card Switches
1 - 64/256K option with 128 installed 2 - 32K options			32K Option Card Switches



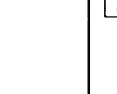

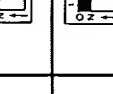
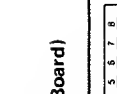
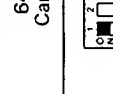
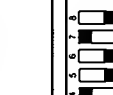
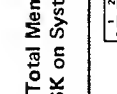

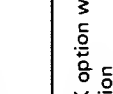
**480K Total Memory
224K + (256K on System Board)**

System Board Switches	Switch Block 1	Switch Block 2
1 - 64/256K option with 192K installed 1 - 32K option		
1 - 64/256K option with 128K installed 1 - 64K option 1 - 32K option		







512K Total Memory
256K + (256K on System Board)

System Board Switches	Switch Block 1	Switch Block 2	
<p>1 - 64/256K option with 128K installed 2 - 64K options</p>			<p>64/256K Option Card Switches</p> 
<p>1 - 64/256K option with 192K installed 1 - 64K option</p>			<p>64K Option Card Switches</p> 
<p>1 - 64/256K option with 192K installed 2 - 32K options</p>			<p>32K Option Card Switches</p> 
<p>1 - 64/256K option with 256K installed</p>			

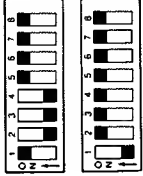

**544K Total Memory
288K + (256K on System Board)**

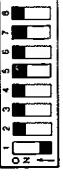
System Board Switches		
1 - 64/256K option with 192K installed 1 - 64K option 1 - 32K option		
1 - 64/256K option with 256K installed 1 - 32K option		



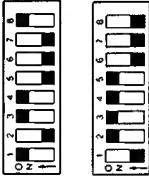
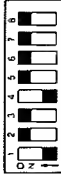

576K Total Memory
320K + (256K on System Board)

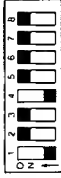
System Board Switches	Switch Block 1	Switch Block 2
1 - 64/256K option with 192K installed 2 - 64K options		
1 - 64/256K option with 256K installed 1 - 64/256K option with 64K installed		
1 - 64/256K option with 256K installed 1 - 64K option		
1 - 64/256K option with 256K installed 2 - 32K options		





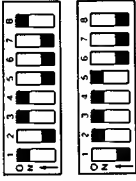

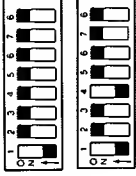
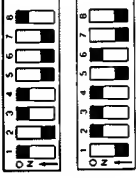

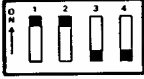

**608K Total Memory
352K + (256K on System Board)**

System Board Switches	Switch Block 1	Switch Block 2
<p>1 - 64/256K option with 256K installed 1 - 64/256K option with 64K installed 1 - 32K option</p>	<p>64/256K Option Card Switches</p> 	<p>64K Option Card Switches</p> 
<p>1 - 64/256K option with 256K installed 1 - 64K option 1 - 32K option</p>	<p>64/256K Option Card Switches</p> 	<p>32K Option Card Switches</p> 

**640K Total Memory
384K + (256K on System Board)**

System Board Switches	Switch Block 1 	Switch Block 2 	
<p>1 - 64/256K option with 256K installed 1 - 64/256K option with 64K installed 1 - 64K option</p>	<p>64/256K Option Card Switches</p> 	<p>64K Option Card Switches</p> 	<p>32K Option Card Switches</p>
<p>1 - 64/256K option with 256K installed 2 - 64K options</p>	<p>64/256K Option Card Switches</p> 	<p>64K Option Card Switches</p> 	
<p>1 - 64/256K option with 256K installed 1 - 64/256K option with 128K installed</p>	<p>64/256K Option Card Switches</p> 		

Extender Card Switch Settings

System Memory	Extender Card Switch Block	Memory Segment
16K to 64K		1
96K to 128K		2
160K to 192K		3
224K to 256K		4
288K to 320K		5
352K to 384K		6
416K to 448K		7
480K to 512K		8
544K to 576K		9
608K to 640K		A

SWITCH SETTINGS

Notes:

Notes:

Notes:

SECTION 6. RELOCATE

Contents

Physical Preparation of the System	6-3
Short Distance Relocate	6-8
Long Distance Relocate for System and Expansion Unit(s)	6-9
Long Distance Relocate for Keyboard	6-10
Long Distance Relocate for IBM Monochrome or Color Display	6-11
Long Distance Relocate for IBM 80 CPS Matrix/Graphics Printer	6-12
Setup At New Location	6-13

Notes:

Physical Preparation of the System

If you have an expansion unit with a fixed disk drive installed, use the following procedure to prevent damage to the fixed disk during relocation.

WARNING: Normal shipping and handling can result in a permanent loss of all data on the fixed disk drive(s). It is recommended that all files be backed up onto diskettes before continuing with this procedure.

Depending on the amount of data stored, you may require as many as 64 diskettes to backup each fixed disk drive. Refer to the *IBM Disk Operating System* manual for a description of the BACKUP command.

1. Insert Diagnostics diskette.
2. Set the Power switch on the expansion unit (if attached) and system unit to ON.
3. The following message should appear on your screen.

SELECT AN OPTION

0 - RUN DIAGNOSTIC ROUTINES

1 - FORMAT DISKETTE



2 - COPY DISKETTE

3 - PREPARE FIXED DISK FOR RELOCATION

9 - EXIT TO SYSTEM DISKETTE

ENTER THE ACTION DESIRED

?

4. Press  then press  .

This step moves the disk head over track 305 which is the position designated for moving your system.

5. The following message should appear on your screen.

SELECT AN OPTION

0 - RUN DIAGNDSTIC ROUTINES

1 - FORMAT DISKETTE

2 - COPY DISKETTE

3 - PREPARE FIXED DISK FOR RELOCATIDN

9 - EXIT TO SYSTEM DISKETTE

ENTER THE ACTION DESIRED

? 3

FIXED DISK(S) READY FOR SHIPPING

6. Remove diskettes from diskette drive unit.

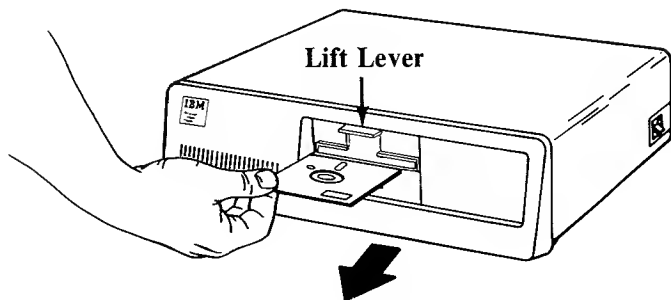

7. Position power switches to OFF on all units (System Unit, Printer, etc.).

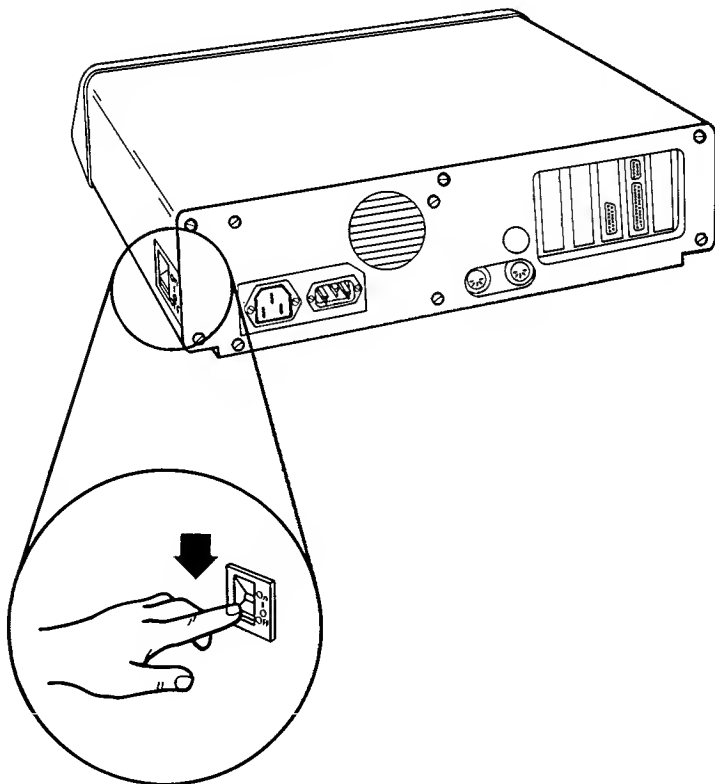

8. Unplug the system unit's (and expansion unit's) power cord from the wall outlet. Disconnect all cables from the rear of the unit(s).

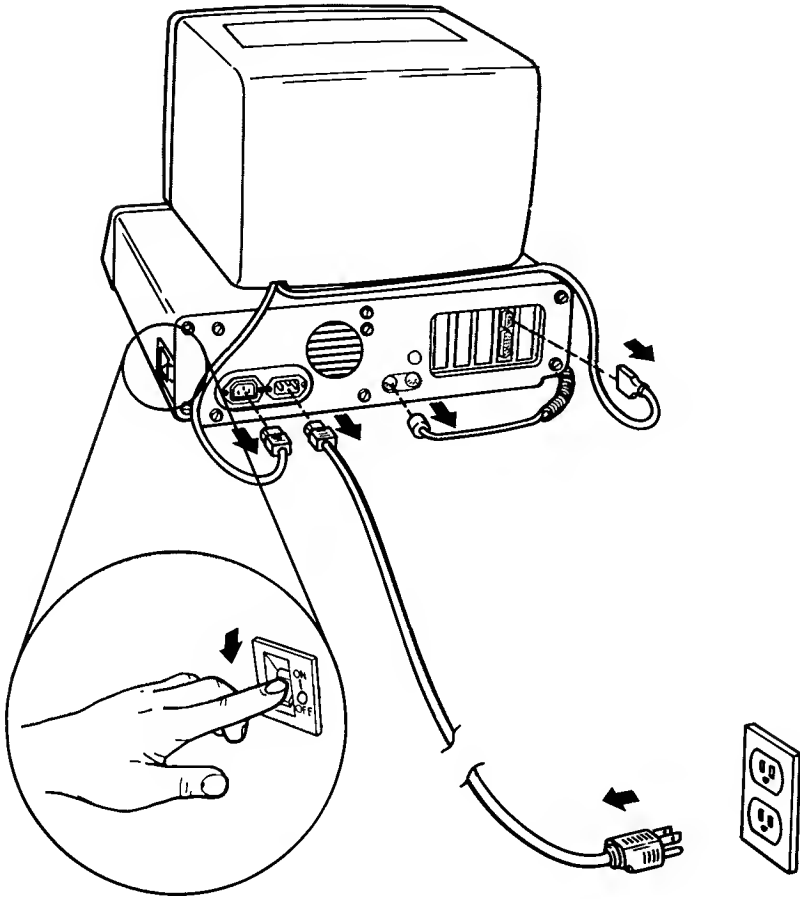

9. Coil the cables to protect the connectors.

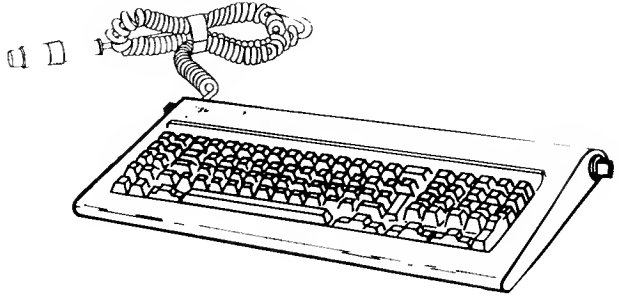

10. Tape coiled cables to system unit (and expansion unit) so the unit(s) may be carried safely. (IBM recommends filament or masking tape.)

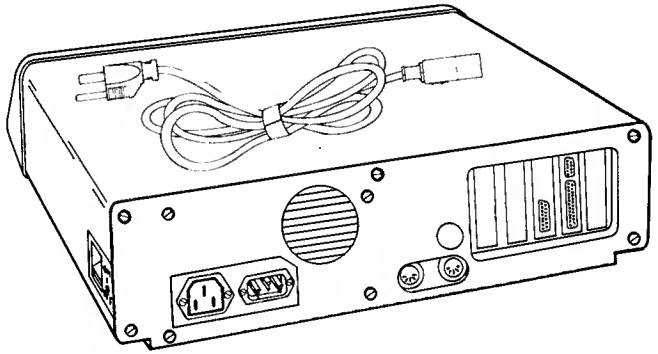

Short Distance Relocate

By short distance, we mean any distance where trucking is not involved. For example, moving from one office or floor to another. We recommend each unit be moved separately.

Note: A second person may be helpful (doors, stairs, etc.).

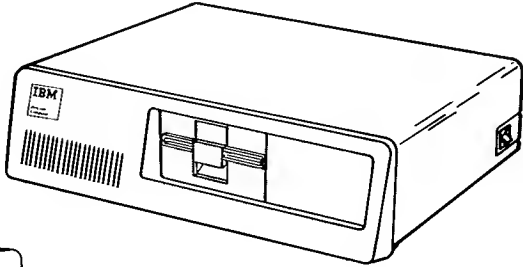

System Unit

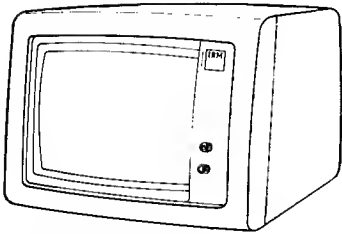

IBM Monochrome Display

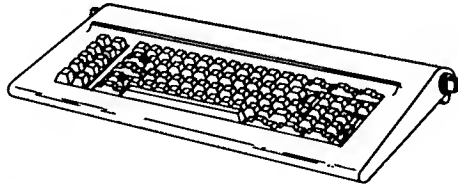

Keyboard

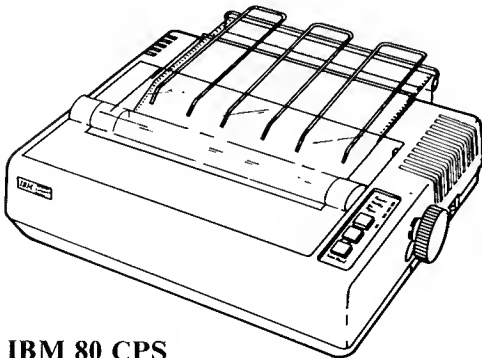

**IBM 80 CPS
Matrix/Graphics Printer**

Long Distance Relocate for System and Expansion Unit(s)

If you have saved the original cartons and packing material that your IBM Personal Computer units were shipped in, use them to pack your units.

If you are using different cartons, cushion well to avoid damage.

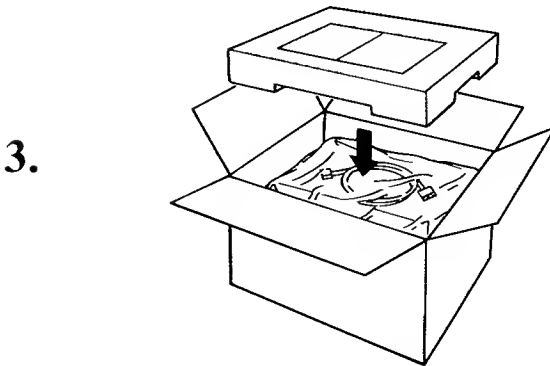
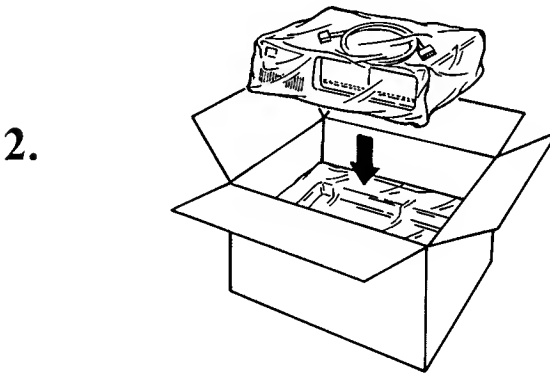
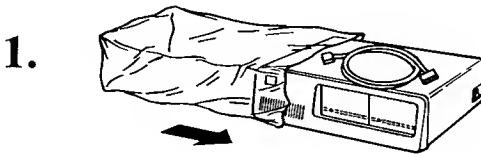

Long Distance Relocate for Keyboard

If you have saved the original cartons and packing material that your IBM Personal Computer units were shipped in, use them to pack your units.

If you are using different cartons, cushion well to avoid damage.

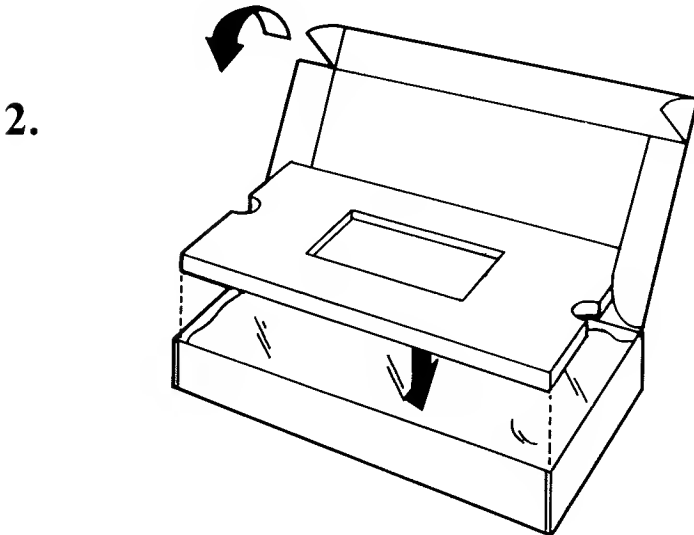
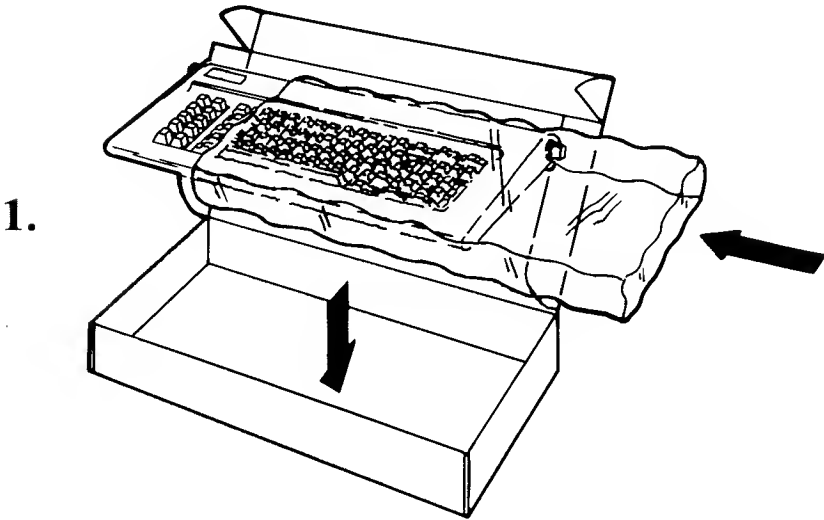

Long Distance Relocate for IBM Monochrome or Color Display

If you have saved the original cartons and packing material that your IBM Personal Computer units were shipped in, use them to pack your units.

If you are using different cartons, cushion well to avoid damage.

1.

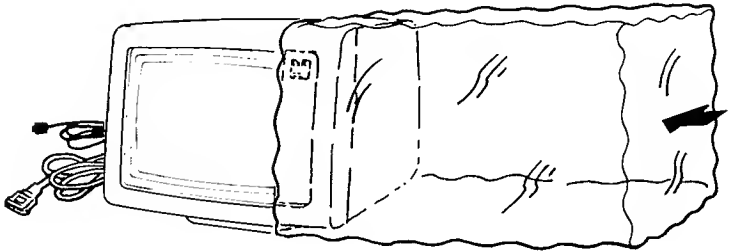

2.

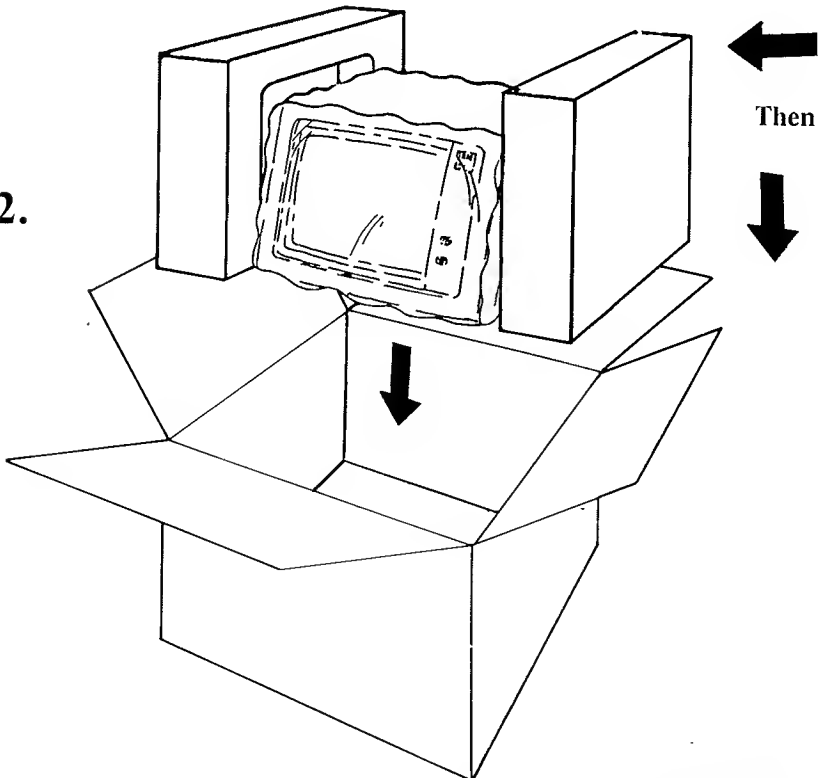

Long Distance Relocate for IBM 80 CPS Matrix/Graphics Printer

If you have saved the original cartons and packing material that your IBM Personal Computer units were shipped in, use them to pack your units.

If you are using different cartons, cushion well to avoid damage.

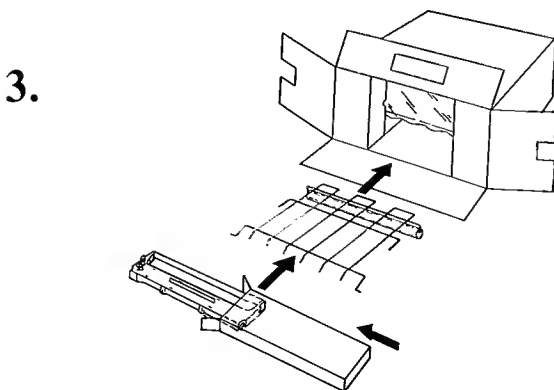
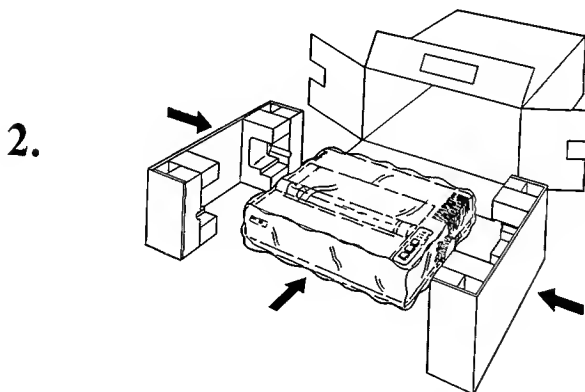
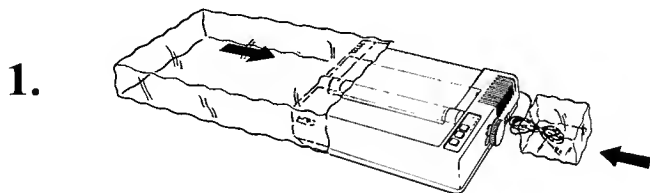

Setup At New Location

When your system arrives at the new location, carefully unpack the system.

For setting up and cabling your IBM Personal Computer, refer to "Setup," Section 2 of this manual.

Notes:

GLOSSARY

ASCII: American Standard Code for Information Interchange. The standard code using a coded character set consisting of 7-bit coded characters (8 bits including parity check), used for information interchange among data processing systems, data communications systems and associated equipment. The ASCII set consists of control characters and graphic characters.

BASIC: Beginner's All-purpose Symbolic Instruction Code. A programming language which uses common English words.

backup: Duplicating data from a fixed disk drive or diskette to a diskette which ensures availability of data in the event of loss or damage to the original.

CPS: Characters per second. Used to measure the printing speed of a printer.

cursor: A bar of light that indicates where data entered from the keyboard will appear on the display.

data: All information entered into or used by the computer.

diskette: A storage device consisting of a flexible magnetic disk inside a protective plastic jacket.

diskette drive: A device which uses diskettes for mass storage and retrieval of data.

DOS: Disk Operating System. A program which interacts with the processor and the disk or diskette drive to control the flow of data.

echo: A DOS function that sends data to be displayed to the printer as well as the screen.

fixed disk: A disk of rigid material with a magnetic coating, used for mass storage and retrieval of data.

formatting: The preparation of a disk or diskette for use by the computer.

formatted disk/diskette: A disk/diskette which can be used by the computer for the storage of data.

joy stick: A user supplied device that connects to the Game Control Adapter.

KB: Kilobyte. A kilobyte equals 1024 bytes of information.

MB: Megabyte. A megabyte equals 1,048,576 bytes of information.

modem: A device that allows information to be exchanged between computers, using telephone lines.

operating system: A program that supervises the execution of user programs by the computer.

POST: Power-On Self Test. A series of diagnostics which are executed each time the IBM Personal Computer's power is turned on.

prototype card: A blank circuit card which can be used to create custom adapters.

SDLC: Synchronous Data Link Control.

typematic: Keyboard buttons that will repeat when held depressed.

INDEX

A

- adding a statement
 BASIC 3-29
- adjustments
 - IBM Color Display
 - brightness Displays 3-3
 - contrast Displays 3-3
 - vertical hold Displays 3-5
 - vertical size Displays 3-6
 - IBM Monochrome Display
 - brightness Displays 3-1
 - contrast Displays 3-1
 - IBM Printers
 - forms thickness
 Printers 3-14
 - left margin Printers 3-15
 - top of page setting
 Printers 3-13
 - tractor assembly
 Printers 3-11
 - keyboard
 - tilt position Setup 2-12
 - screen alignment Setup 2-19
- alternate key Keyboard 3-3
- art (*see* SAMPLES program)
- ASCII codes Printers 3-32
- Asynchronous Communications
 - communications menu
 BASIC 3-17
 - description of
 - communications program
 BASIC 3-18
 - Dow Jones/News Retrieval
 BASIC 3-18
 - end communication program
 BASIC 3-19
 - option examples
 Introduction 1-6

- running the communication
 program BASIC 3-16
- Series/1 communication
 BASIC 3-18
- The Source BASIC 3-19

B

- backspace key Keyboard 3-3
- ball (*see* SAMPLES program)
- BASIC
 - adding a statement
 BASIC 3-29
 - Advanced BASIC
 BASIC 3-6
 - BASIC commands with
 DOS counterparts
 BASIC 3-9
 - BASIC prompt BASIC 3-7
 - cassette BASIC BASIC 3-5
 - changing BASIC programs
 BASIC 3-25
 - COMM program
 BASIC 3-16
 - communication program
 BASIC 3-16
 - DOS, returning to
 BASIC 3-9
 - EDIT command
 BASIC 3-28
 - entering BASIC programs
 BASIC 3-23
 - Files command BASIC 3-21
 - introduction BASIC 3-3
 - KILL command BASIC 3-9
 - LIST command
 BASIC 3-26

- NAME command
 - BASIC 3-9
- remove a statement
 - BASIC 3-30
- returning to DOS
 - BASIC 3-9
- retyping a statement
 - BASIC 3-27
- running a BASIC program
 - BASIC 3-11
- running BASIC on another diskette with 1 drive
 - BASIC 3-20
- running BASIC on another diskette with 2 drives
 - BASIC 3-21
- running the communications program
 - BASIC 3-16
- running the SAMPLES program
 - BASIC 3-12
- screen alignment
 - BASIC 3-8
- startup screen
 - BASIC 3-7
- starting Advanced BASIC
 - BASIC 3-6
- starting BASIC
 - BASIC 3-5
- starting Cassette BASIC
 - BASIC 3-5
- starting Disk BASIC
 - BASIC 3-6
- stopping BASIC program
 - (see break)
- storing BASIC programs
 - BASIC 3-25
- break
 - Keyboard 3-8
- brightness control
 - color display Displays 3-3
 - monochrome display Displays 3-1
- byte
 - DOS 3-22
- cap lock key
 - Keyboard 3-7
- cartridge ribbon installation
 - Printers 3-5
- cassette
 - BASIC BASIC 3-3
 - diagnostics Problem Determination 4-1
 - file names BASIC 3-21
 - loading diagnostics Problem Determination 4-1
 - starting cassette BASIC BASIC 3-5
- character charts
 - Printers 3-32
- checking electrical connection
 - Problem Determination 4-1
- CHKDSK command
 - DOS 3-45
- circle (see SAMPLES program)
- color (see SAMPLES program)
- color display
 - controls Displays 3-3
 - moving Relocate 6-11
 - vertical hold adjustment Displays 3-5
 - vertical size adjustment Displays 3-6
- commands
 - CHKDSK DOS 3-45
 - COMP DOS 3-45
 - COPY DOS 3-64
 - DATE DOS 3-45
 - DIR DOS 3-53
 - DISKCOMP DOS 3-46
 - DISKCOPY DOS 3-57
 - EDIT BASIC 3-28
 - ERASE DOS 3-78
 - FILES BASIC 3-21
 - FORMAT DOS 3-48
 - KILL BASIC 3-9
 - LIST BASIC 3-26
 - MODE DOS 3-81
 - NAME BASIC 3-9
 - RENAME DOS 3-75
 - SYS DOS 3-46
 - TIME DOS 3-46
 - TYPE DOS 3-73

C

- cabling, system
 - Setup 2-3
- calendar (see SAMPLES program)

- communication program
 - description BASIC 3-18
 - Dow Jones/News Retrieval BASIC 3-18
 - IBM Personal Computer BASIC 3-18
 - Series/1 BASIC 3-18
 - The Source BASIC 3-19
 - other services BASIC 3-19
- COMP command DOS 3-45
- contrast control
 - color display Displays 3-3
 - monochrome display Displays 3-1
- control codes Printers 3-19
- control key Keyboard 3-3
- controls
 - color display Displays 3-3
 - cursor down Keyboard 3-6
 - cursor left Keyboard 3-6
 - cursor right Keyboard 3-6
 - cursor up Keyboard 3-6
 - monochrome display Displays 3-1
 - printer Printers 3-4
- COPY command DOS 3-64
- cursor control keys Keyboard 3-6

D

- DATE command DOS 3-45
- default drive DOS 3-13
- delete key Keyboard 3-6
- diagnostics Problem Determination 4-1
- disk (*see* diskette)
- DIR command DOS 3-53
- DISKCOMP command DOS 3-46
- DISKCOPY command DOS 3-57

- diskette
 - care of diskettes DOS 3-24
 - description DOS 3-22
 - diskette in-use light Setup 2-18
 - diskette operating system (*see* DOS)
 - loading Setup 2-18
 - preparing for use (*see* FORMAT command)
 - write-protect notch DOS 3-25
- displays
 - IBM Color Display Displays 3-5
 - IBM Monochrome Display Displays 3-1
- donkey (*see* SAMPLES program)
- DOS (Disk Operating System)
 - backing up DOS with one drive DOS 3-27
 - backing up DOS with two drives DOS 3-31
 - backing up one file DOS 3-64
 - controlling DOS DOS 3-14
 - COPY command DOS 3-64
 - copying file with one drive DOS 3-67
 - copying file with two drives DOS 3-71
 - DATE command DOS 3-45
 - default drive DOS 3-13
 - DIR command DOS 3-53
 - DISKCOPY command DOS 3-57
 - DOS diskette files DOS 3-44
 - DOS function keys Keyboard 3-10
 - DOS prompt DOS 3-11
 - echo DOS 3-20

- ERASE command
 - DOS 3-78
- file specifications
 - DOS 3-38
- files and filenames
 - DOS 3-35
- FORMAT command
 - DOS 3-48
- formatting several diskettes
 - DOS 3-51
- global filename characters
 - DOS 3-39
- introduction to DOS
 - DOS 3-3
- MODE command DOS 3-81
- print as you type (*see* echo)
- print screen DOS 3-19
- RENAME command
 - DOS 3-75
- screen alignment DOS 3-81
- starting DOS DOS 3-5
- stopping a DOS command
 - DOS 3-17
- stopping screen DOS 3-19
- summary of commands
 - DOS 3-45
- SYS command DOS 3-46
- TIME command DOS 3-46
- TYPE command DOS 3-73

E

- echo Keyboard 3-11,
 - DOS 3-20, DOS 3-73
- end key Keyboard 3-6
- enter key Keyboard 3-3
- ERASE command DOS 3-78
- escape key Keyboard 3-3

- examples
 - error message Problem
 - Determination 4-1
 - errors Problem
 - Determination 4-1
 - printer printout
 - Printers 3-17
- expansion unit Setup 2-9
 - moving Relocate 6-3, 6-9
 - problem determination
 - Problem Determination 4-1

F

- files DOS 3-35
- file specifications DOS 3-38
- FILES command DOS 3-21
- filenames DOS 3-35
 - global DOS 3-39
- form feed Printers 3-4
- FORMAT command
 - DOS 3-48
- forms loading Printers 3-8
- forms rack Printers 3-9
- function keys Keyboard 3-4

G

- global filenames DOS 3-39
- graphic printer (*see* printer)

H

- home key Keyboard 3-6
- how to
 - cable system unit Setup 2-3
 - determine problem
 - Problem Determination 4-1

install system unit Setup 2-3
list installed Problem
Determination 4-1
load BASIC BASIC 3-5
load BASICA BASIC 3-6
load Disk BASIC
BASIC 3-6

I

insert key Keyboard 3-6
installations
devices, options, and memory
Options 5-1
Personal Computer
Setup 2-3
print forms Printers 3-8
print ribbon cartridge
Printers 3-5
intensity control (*see* brightness)
introduction Introduction 1-3
isolating problem Problem
Determination 4-1

K

keyboard
adjustment Setup 2-12
BASIC usage Keyboard 3-2
DOS usage Keyboard 3-9
installation Setup 2-4
moving Relocate 6-10
keys
alternate Keyboard 3-3
backspace Keyboard 3-3
cap lock Keyboard 3-7
control key Keyboard 3-3
cursor controls
Keyboard 3-6
delete Keyboard 3-6
enter Keyboard 3-3
escape Keyboard 3-3
function Keyboard 3-4

insert Keyboard 3-6
minus Keyboard 3-5
number lock Keyboard 3-5
numeric keypad
Keyboard 3-5
plus Keyboard 3-5
print screen Keyboard 3-7
scroll lock Keyboard 3-7
shift Keyboard 3-3
spacebar Keyboard 3-2
tab Keyboard 3-3
typewriter area
Keyboard 3-1

KILL command BASIC 3-9
knob roller Printers 3-12

L

least significant bit (LSB)
Printers 3-28
left margin adjustment
Printers 3-15
levers
diskette load Setup 2-18
forms thickness control
Printers 3-14
tractor lock Printers 3-11
lights
color display (power on)
Displays 3-3
diskette (in-use) Setup 2-18
printer Printers 3-3
line feed Printers 3-4
LIST command BASIC 3-26
load
Diagnostics cassette
Setup 2-20, Problem
Determination 4-1
Diagnostics diskette
Setup 2-18, Problem
Determination 4-1
loading forms Printers 3-8

M

- matrix printer (*see* printer)
- minus key Keyboard 3-5
- MODE command DOS 3-81
- modes Printers 3-18
- monochrome display
 - moving Relocate 6-11
 - operating Displays 3-1
- mortgage (*see* SAMPLES program)
- most significant bit (MSB) Printers 3-28
- moving
 - color display Relocate 6-11
 - expansion unit Relocate 6-3
 - keyboard Relocate 6-10
 - monochrome display Relocate 6-11
 - printers Relocate 6-12
 - system unit Relocate 6-9
- music (*see* SAMPLES program)

N

- NAME command BASIC 3-9
- no paper light Printers 3-3
- number lock key Keyboard 3-5
- numeric keypad Keyboard 3-5

O

- on/line light Printers 3-3
- On/Off switch
 - color display Displays 3-2
 - printers Printers 3-1
 - system unit Setup 2-5
- option examples
 - asynchronous communications Introduction 1-7
 - color display Introduction 1-7

- Color/Graphics Monitor Adapter Introduction 1-6
- diskette drive
 - Introduction 1-5
- expansion unit
 - Introduction 1-6
- monochrome display
 - Introduction 1-6
- printers Introduction 1-6
- printer adapter
 - Introduction 1-6
- prototype card
 - Introduction 1-7

P

- piechart (*see* SAMPLES program)
- plus key Keyboard 3-5
- power On/Off
 - color display Displays 3-2
 - printer Printer 3-1
 - system unit Setup 2-5
- Power-On Self Test (POST)
 - printer Printers 3-16
 - system unit Setup 2-7
- print screen key Keyboard 3-7
- printer
 - ASCII codes Printers 3-32
 - character chart Printers 3-32
 - control buttons Printers 3-4
 - control codes Printers 3-19
 - form feed button Printers 3-4
 - forms loading Printers 3-8
 - forms rack Printers 3-9
 - forms thickness control lever Printers 3-14
 - graphics codes Printers 3-34
 - left margin adjustment Printers 3-15
 - lights Printers 3-3
 - Line Feed button Printers 3-4

moving Relocate 6-12
 No Paper light Printers 3-3
 On Line button Printers 3-4
 On Line light Printers 3-3
 Power light Printers 3-3
 power switch Printers 3-2
 print modes Printers 3-18
 print scale Printers 3-9
 printout samples
 Printers 3-17
 Ready light Printers 3-3
 relocate Relocate 6-12
 ribbon cartridge installation
 Printers 3-5
 roller knob Printers 3-12
 self test Printers 3-16
 top of page setting
 Printers 3-13
 tractor Printers 3-11
 tractor lock lever
 Printers 3-11
 problem determination
 procedures Problem
 Determination 4-1

R

ready light Printers 3-3
 relocate
 color display Relocate 6-11
 expansion unit
 Relocate 6-3, 6-9
 keyboard Relocate 6-10
 monochrome display
 Relocate 6-11
 printers Relocate 6-12
 system unit Relocate 6-9
 return to DOS BASIC 3-9

S

SAMPLES program
 BASIC 3-12
 scratch diskette Problem
 Determination 4-1
 screen alignment Setup 2-21
 scroll lock key Keyboard 3-7
 sectors DOS 3-22
 self test, printers Printers 3-16
 service information Problem
 Determination 4-1
 shift key Keyboard 3-3
 space (*see* SAMPLES program)
 spacebar Keyboard 3-2
 starting
 Advanced BASIC
 BASIC 3-6
 Cassette BASIC
 BASIC 3-5
 Disk BASIC BASIC 3-6
 DOS DOS 3-5
 summary of DOS command
 DOS 3-45
 SYS command DOS 3-46
 system cabling Setup 2-3
 system unit Setup 2-3
 moving Relocate 6-9
 problem determination
 Problem Determination 4-1

T

tab key Keyboard 3-3
 TIME command DOS 3-46
 top of page setting
 Printers 3-13
 track diskette DOS 3-22
 tractor Printers 3-11
 tractor lock lever Printers 3-11
 TYPE command DOS 3-73
 tpestyles Printers 3-18
 typewriter area Keyboard 3-2

U

units

expansion unit Setup 2-9

system unit Setup 2-3

V

vertical hold adjustment

Displays 3-5

vertical size adjustment

Displays 3-6

W

wrap plug Problem

Determination 4-1

communication Problem

Determination 4-1

write-protect notch DOS 3-25



Readers Comment Form

GUIDE TO OPERATIONS

1525818

Your comments assist us in improving the usefulness of our publication; they are an important part of the input used for revisions.

IBM may use and distribute any of the information you supply in any way it believes appropriate without incurring any obligation whatever. You may, of course, continue to use the information you supply.

Please do not use this form for technical questions regarding the IBM Personal Computer or programs for the IBM Personal Computer, or for requests for additional publications; this only delays the response. Instead, direct your inquiries or requests to your authorized IBM Personal Computer dealer.

Comments:

Fold here

BOCA RATON, FLORIDA 33432
P.O. BOX 1328-C
SALES & SERVICE
IBM PERSONAL COMPUTER

POSTAGE WILL BE PAID BY ADDRESSEE

BUSINESS REPLY MAIL
FIRST CLASS PERMIT NO. 321 BOCA RATON, FLORIDA 33432

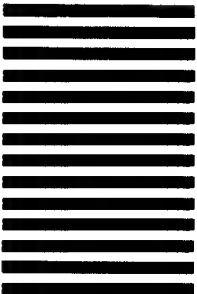

NO POSTAGE
NECESSARY
IF MAILED
IN THE
UNITED STATES

